

Models

ES750 ES1500

ES1000 ES1800

ES1300 ES2200

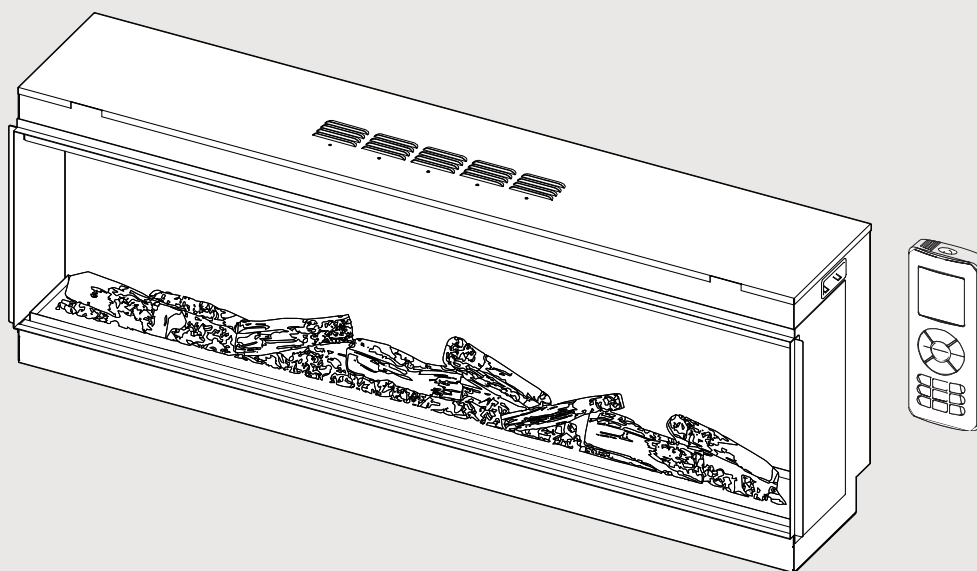

Electric Fire Series

Operation and Installation Guide

Rinnai

Important

This appliance shall be installed in accordance with:

- Manufacturer's installation instructions

Current:

- AS/NZS 3000 Electrical Standards

Appliance must be installed, commissioned, serviced, and removed by an authorised person.

The ES Series of electric fires are suitable for domestic applications only.

Warning

Improper installation, adjustment, alteration, service or maintenance can cause property damage, personal injury or loss of life.

For more information about buying, using, and servicing of Rinnai appliances call: 0800 RINNAI (0800 746 624).

Rinnai New Zealand Limited
105 Pavilion Drive, Mangere, Auckland
PO Box 53177, Auckland Airport, Auckland 2150

Phone: (09) 257 3800
Email: info@rinnai.co.nz
Web: rinnai.co.nz
[youtube.com/rinnainz](https://www.youtube.com/rinnainz)
[facebook.com/rinnainz](https://www.facebook.com/rinnainz)

Contents

Warnings and important information.....	4
Operation.....	5
Remote control	6
Cleaning and troubleshooting.....	8

Installation

Before starting	9
Specification summary	10
Appliance location	12
Cavity.....	13
Installation	14
Installation configurations	15
Installation fixing options	16
Finishing	17
Limited Warranty	18

Warnings and important information

This appliance is not intended for use by persons (including children) with reduced physical, sensory or mental capabilities, or lack of experience and knowledge, unless they have been given supervision or instruction concerning use of the appliance by a person responsible for their safety.

- The unit must not be used or operated if any part of the appliance is damaged
- Do not place articles on or against this appliance
- Do not use or store flammable materials near this appliance
- Do not spray aerosols in the vicinity of this appliance while it is in operation
- Do not modify this appliance
- Do not locate the fire immediately below a power socket outlet (potential fire hazard)

Electrical safety

The ES fires come with a 1.6 m power cord and 3-pin plug, on the right hand side (looking at the unit). The plug must remain accessible after the appliance is installed. **DO NOT** use power boards, double adapters, or extension leads. The cord and plug must not be modified. If the cord or plug are damaged, it must be replaced by genuine Rinnai replacement parts.

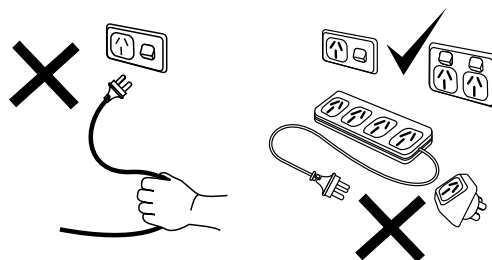

The unit **MUST NOT** be located below an electric socket outlet.

The connection of the appliance to a permanent electrical supply (hard-wiring) and the installation of any other electrical wiring, power outlets, and switches must be performed by an authorised person, such as a licensed electrician. The electric isolation switch must be accessible after the appliance has been installed.

DO NOT connect the appliance to mains power until it has been installed in its final location and adjusted to the position it will be used in.

DO NOT handle any parts of the unit, including the plug and flexible cord, with wet or damp hands.

General safety

- **DO NOT** place containers of any liquid on the unit
- **DO NOT** sit on the unit
- **DO NOT** place items of clothing, hand towels or similar over the appliance to dry
- **DO NOT** leave the appliance unattended whilst in operation
- **DO NOT** use this appliance in areas where the presence of flammable dust particles can cause an explosion



When operating, the surfaces of this appliance will get **VERY HOT**. **DO NOT** touch any part of the appliance while it is turned on.

Disposal guidelines



This appliance contains potentially hazardous materials. Do not dispose of this product as household waste.

Operation

The electric fire range can be operated in three ways:

1. Manual control
2. Remote control
3. Wi-Fi¹ (contact Rinnai for more information, this uses a third party app independent of Rinnai)

Each time a button is pressed on the appliance or on the remote control an audible beep is emitted. To turn off this feature hold the preset button on the appliance for three seconds.

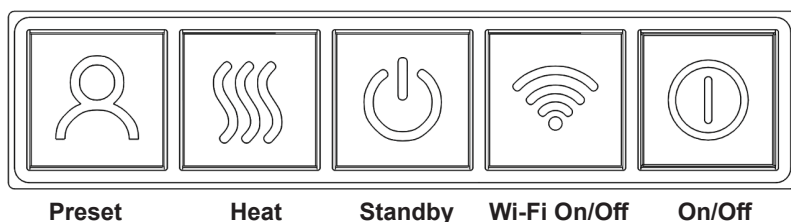

Preset

Press repeatedly to cycle through the six preset modes.

Heat

- | | |
|-----------|------------------------|
| 1 press | = cool blow |
| 2 presses | = low heat setting |
| 3 presses | = high heat setting |
| 4 presses | = no heat or cool blow |

Standby

- Turns on the appliance with the last used settings without any heat.
- Places the appliance into standby mode with all features turned off.

Wi-Fi¹ On/Off

Press to turn the Wi-Fi on or off. An illuminated LED on the button indicates that Wi-Fi is turned on. Hold the button for three seconds to enter device pairing mode.

On/Off

- Press to turn on power to the appliance.
- Button pushed in indicates power is on, button pushed out indicates power is off.

¹ The electric fire app is called the TUYA SMART APP. This is a third party App independent of Rinnai. For this APP to run, the home's internet router must be running on 2.4 GHz.

Remote control

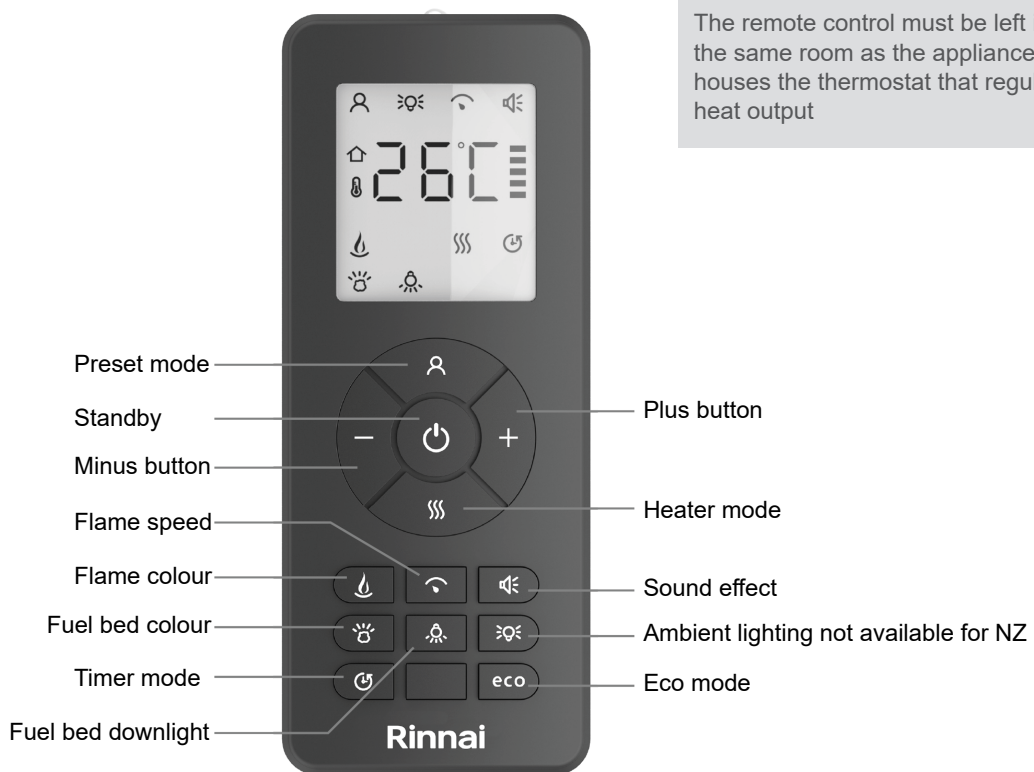

Remote control batteries



KEEP BATTERIES OUT OF REACH OF CHILDREN

DO NOT:

- Mix old and new batteries
- Mix different types of batteries
- Heat or expose to flame
- Take apart
- Attempt to recharge alkaline batteries
- Use damaged batteries

Dispose of used batteries safely.

To avoid damage from leaking batteries, remove batteries if controller is not going to be used for a long periods.

Ensure that the two AAA batteries are inserted into the remote control. The battery power level is indicated by the column of bars to the right side of the temperature display when in standby mode. Five bars indicates the batteries are full.

Remote control setup

Press and hold the Standby button until you hear one beep, the remote is now connected with the appliance.

Preset

Repeatedly press to cycle through the six preset fire modes (plus three user defined presets, if programmed).

Pr.1	Autumn campfire	Pr.6	Nebula
Pr.2	Ember glow	Pr.7	User defined
Pr.3	Inferno	Pr.8	User defined
Pr.4	Noir	Pr.9	User defined
Pr.5	Fire and ice		

User defined - personalised settings

Choose the flame colour¹, the fuel bed colour¹, and the fuel bed downlight colour¹. Once you have selected your desired combination:

- Press and hold the Preset button for three seconds until the LCD displays FL.7.
- Press - and + buttons to select a user defined number between 7-9.
- Press and hold the Preset button for three seconds to confirm the preset.

¹ = plus brightness level

Standby

- Turns on the appliance to the last used settings without any heat.
- Places the appliance into standby mode with all features turned off.

Plus (+) and minus (-) buttons

Use to navigate the different on-screen menus.

Flame speed

Press once to enter the flame speed menu, SPd will show on the screen. Press the + or - buttons to adjust the flame speed. The flame speed is indicated on the screen by bars, one bar is the slowest setting, five bars the highest.

Flame colour

Repeatedly press to cycle through the flame colour menu. While in the flame colour menu, press the + or - buttons to increase or decrease the flame brightness, one bar is the lowest setting, five bars is the brightest setting.

FL.0	Flame off	FL.5	Light blue
FL.1	Red	FL.6	Dark blue
FL.2	Orange	FL.7	Violet
FL.3	Yellow	FL.8	White
FL.4	Green	FL.9	Multi-colour change

Fuel bed colour

Repeatedly press to cycle through the fuel bed colour menu. While in the fuel bed colour menu, press the + or - buttons to increase or decrease the fuel bed brightness, one bar is the lowest setting, five bars is the brightest setting.

Fb.0	Flame off	Fb.5	Light blue
Fb.1	Red	Fb.6	Dark blue
Fb.2	Orange	Fb.7	Violet
Fb.3	Yellow	Fb.8	White
Fb.4	Green	Fb.9	Multi-colour change

Timer mode

Repeatedly press to cycle through timer options. Select an amount of time for the appliance to operate, then to automatically turn off. Choose between 0.5, 1, 2, 3, 4, 5, 6, 7, 8, 9 hours.

Eco

This mode will reduce the brightness of all lighting modes and limit the heat output to a low setting. To exit this mode, press the button a second time.

Fuel bed downlight

Repeatedly press to cycle through the fuel bed downlight colour menu. While in the fuel bed downlight menu, press the + or - buttons to increase or decrease the fuel bed brightness, one bar is the lowest setting, five bars is the brightest setting.

dL.0	Light off	dL.5	Light blue
dL.1	Red	dL.6	Dark blue
dL.2	Orange	dL.7	Violet
dL.3	Yellow	dL.8	White
dL.4	Green	dL.9	Multi-colour change

Heater

Press to cycle through the heating options:

- 1 press: CO.A = cool blow
- 2 presses: H.Lo = low heat
- 3 presses: H.HI = high heat
- 4 presses: no.H = no heat

While in heater mode, after selecting the low or high heat setting, press the - and + buttons to select the temperature you want the room to reach.



If the room temperature is already higher than the temperature selected, the unit will not activate.

To switch between °C or °F, hold the - and + buttons for three seconds.

Open window detection is an innovative eco feature that detects a rapid drop in room temperature caused by an open window. The warning word 'OPn' will be displayed on the screen and the unit will be turned off. If the room temperature rises, or the remote control is operated manually, the unit will return to its normal working state.

Sound effect

Press the sound effect button:

- 1 press: S.on = Sound effect on
- 2 press: no.S = Sound effect off

While in the sound effect menus, press the - and + buttons to increase and decrease the volume, one bar is the quietest setting.

Cleaning



Always disconnect the appliance from the power supply and allow to cool before cleaning.

Your appliance needs very little maintenance, however it should be regularly cleaned using a dry cloth. Do not use detergents, abrasive cleaners or furniture polish. To clean the glass, use a lightly damp cloth and ensure any moisture is dried fully using a lint free cloth.

Ensure the unit vent is kept dust free by regularly (monthly or more frequently) vacuuming the vent area with a brush attachment. This will keep it working efficiently.

Troubleshooting

Electronic Safety Control

The appliance is fitted with an Electronic Safety Control (ESC). This is a safety device which switches off the fire if the appliance overheats. If the unit stops operating but the flame effect continues this indicates that the ESC is in operation. The ESC can only be reset after the appliance has cooled down and has been reset. Resetting the ESC is as follows:

1. Switch off the appliance (manual on/off switch) and wait for approximately 10-15 minutes.
2. Switch the power off at the wall.
3. Remove any obstruction to the fan unit outlet or fan blades etc.
4. Re-connect the power supply, and switch on the appliance, the ESC will be reset.
5. Ensure that the appliance is functioning correctly. If the ESC operates again, the appliance and wiring should be checked by an authorised electrician.

Use the information below to help determine if a service call is required. If you are unsure about the way your unit is operating, or if you have any other faults or problems, please refer to your installer or contact Rinnai (0800 746 624).

Problem	Possible cause	Suggested action
Appliance won't turn on	Problem with power supply	Check that the appliance is plugged into the power supply and is switched on. Check that the main switch on the appliance is turned on. Possible fuse fault in the plug, contact an electrician for advice.
	Remote control doesn't work	Replace batteries
	Remote has not synced with the appliance	Check appliance is turned on. Re-sync the remote by pressing the - and + buttons at the same time for three seconds.
No heat	Incorrect thermostat setting	Increase the desired temperature higher than the current room temperature.
	ESC may have activated	Reset ESC, refer procedure above.
Appliance turns off before desired temperature is reached	Open window detection may have activated.	Check if any windows in the room are open.
	Remote control is in an another room	Relocate the remote control to the same room as the appliance

Installation

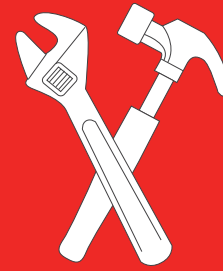

Installation, servicing, repair, and removal shall be carried out only by authorised personnel.

Before starting

Unpack the appliance and components, and remove all transit packaging. Check for damage. DO NOT install any damaged items. If the mains power supply lead is damaged in any way, it MUST be replaced by a suitable equivalent approved by the manufacturer. Check all components have been supplied, refer below.

Read these instructions to get an overview of the steps required before starting the installation. Failure to follow these instructions could cause a malfunction of the appliance. This could result in serious injury and/or property damage.

The main box contains the appliance, two suction cups, and one magnet tool. Packaged with the appliance, behind the glass panel, are additional boxes each with a contents list printed on the outside of each box.

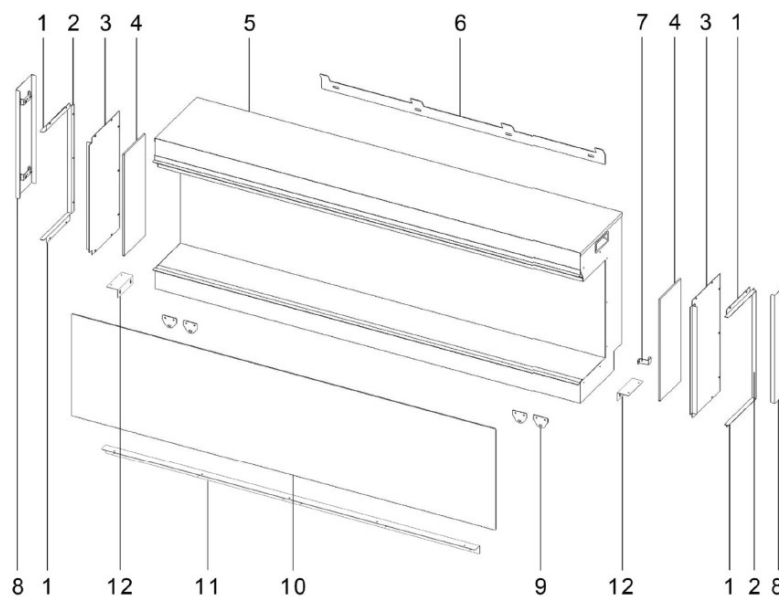

Item	Description	Qty.	Item	Description	Qty
1	Side glass trim (top/bottom)	4	12	Shelf support bracket (short)	2
2	Side glass trim	2	13	Orange glass suction cup	2
3	Metal side panel	2	14	Magnet tool	1
4	Side glass panel	2	15	Power cord 1.6 m	1
5	Appliance body	1	-	Remote control	1
6	Wall mounting bracket	1	-	AAA batteries	2
7	Power cable securing bracket	1	-	ST4*8 screw	19
8	Magnetic side decorative panel	2	-	Decorative fuel log set	1
9	Small mounting bracket	1	-	Bag of glass embers	1
10	Front glass panel	1	-	Bag of vermiculite granules	1
11	Shelf support bracket (long)	1			

Specification summary

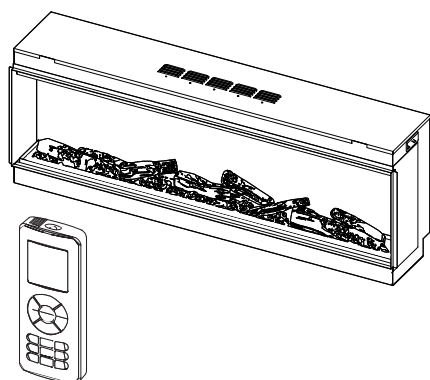

Electric flame effect fires with realistic flame pattern, operated by remote control. Six models to choose from.

Suitable for indoor domestic applications only.

Features

- Realistic glowing fuel bed with burning embers
- Easy to install
- Three independently controlled lighting effects
- Six preset trilight themes
- Open door/window detection

Heat output	0.9-1.8 kW					
Heating modes	Three heating modes, and a cool blow function					
Data plate position	Left hand side on the underside of the appliance					
Electrical supply	230-240 V AC, 50 Hz Ensure voltage and frequency of the power supply correspond to the ratings on the data plate of appliance.					
3-pin plug type	10 A, power cord 1.6 m (right-hand side, looking at the unit)					
Max. power consumption	2000 W					
Power for flame effect	750 28 W	1000 40 W	1300 50 W	1500 52 W	1800 62 W	2200 80 W
Weights (kg)	750 47.5	1000 44.5	1300 54.3	1500 59.3	1800 70.8	2200 87.0

Auxiliary electricity consumption

- At nominal heat output - 12.5 W
- At minimum heat output - 12 W
- Standby - 1.1 W

Dimensions

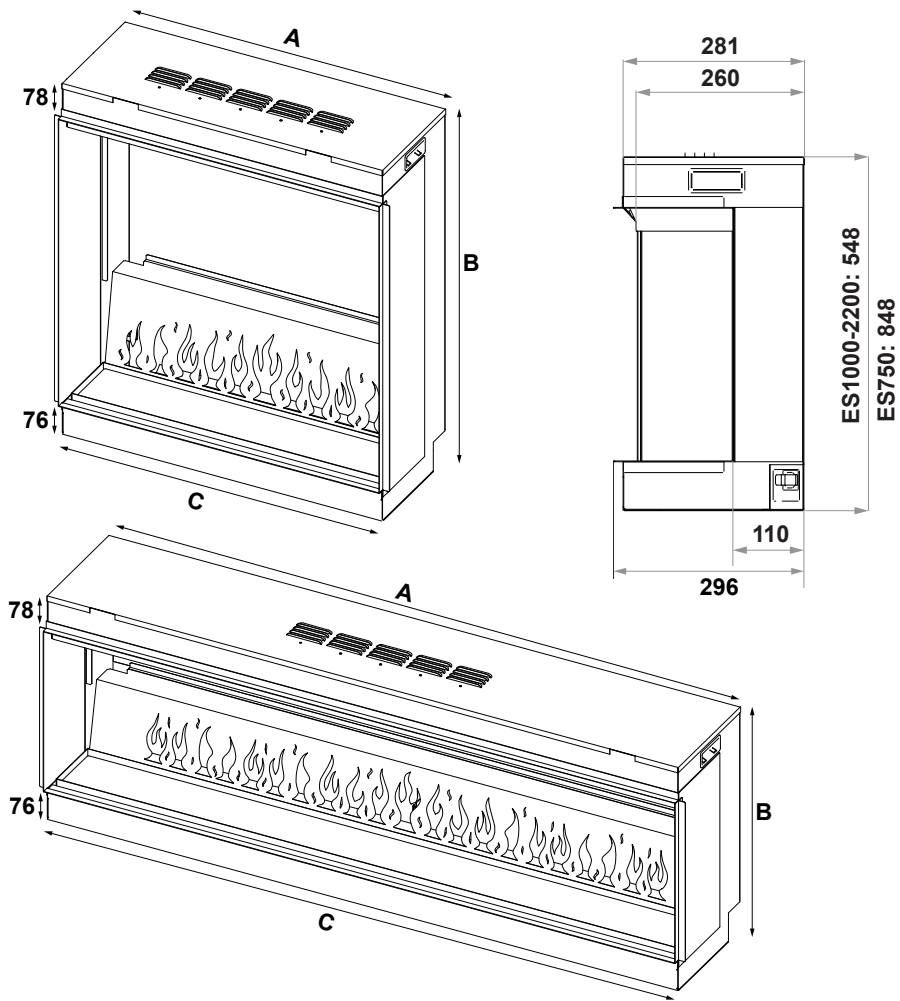

Model	Firebox width back - A	Firebox total height - B	Glass width - C
ES750	780 mm	848 mm	750 mm
ES1000	1030 mm	548 mm	1000 mm
ES1300	1330 mm	548 mm	1300 mm
ES1500	1530 mm	548 mm	1500 mm
ES1800	1830 mm	548 mm	1800 mm
ES2200	2230 mm	548 mm	2200 mm

Appliance location

The main considerations when positioning the unit are:

- Ensuring all minimum clearance requirements as shown below are met
- Allowing sufficient access for ease of operation, servicing, and removal of the appliance.

Electrical

Ensure the 3-pin plug is accessible and connected to a dedicated 230 V, 50 Hz, 10 A earthed power point supplied from mains electricity. The unit must not be located below and electric socket outlet.

The connection of the appliance to a permanent electricity supply (hard-wiring) and the installation of any other electrical wiring, power outlets, and switches **MUST** be performed by a licensed electrician.

Wall cavity

Any wall cavities above the fire need to be blocked off to avoid heat loss and poor heating performance. If installing into an existing fireplace, chimney, or wall cavity, always block off space above and around the unit to prevent heat loss and drafts. Failure to do this may cause the appliance to cut out.

Clearances to combustibles

The minimum clearances shown **MUST** be maintained. This appliance must not be installed where curtains or other combustible materials could come into contact or in close proximity with it. In some cases curtains may need restraining.

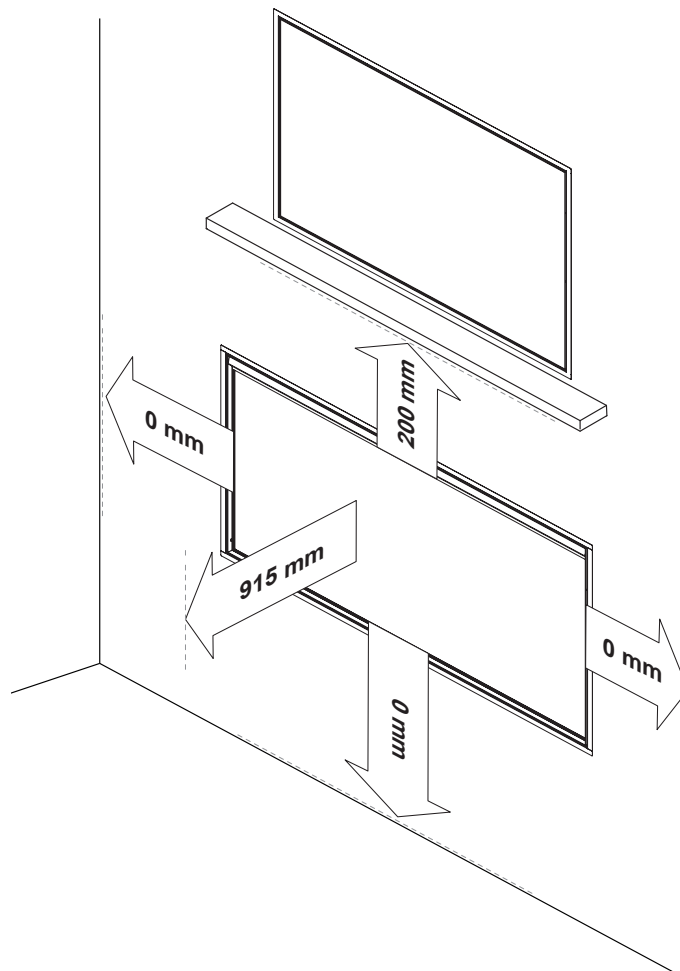

Cavity

Cavity dimensions (mm)					
Model	Height	Width			Depth
		1-sided	2-sided	3-sided	
ES750	858	786	768	750	301
ES1000	558	1036	1018	1000	301
ES1300	558	1336	1318	1300	301
ES1500	558	1536	1518	1500	301
ES1800	558	1836	1818	1800	301
ES2200	558	2236	2218	2200	301

ALWAYS measure the appliance on site before cutting the cavity

To avoid heat loss and draft, block off space above the unit, ensuring 40 mm vertical clearance (A). Failing to do this may cause the unit to cut out.

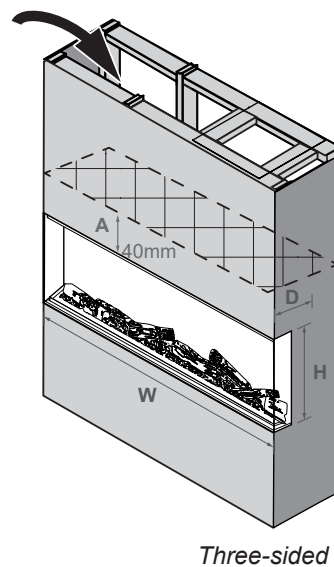
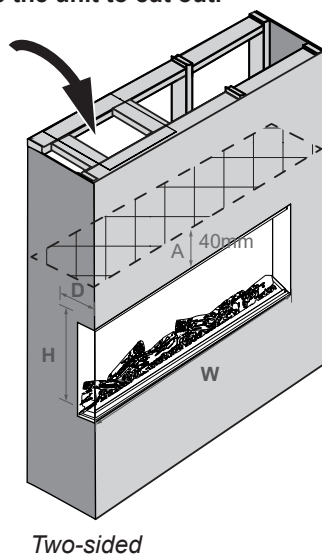
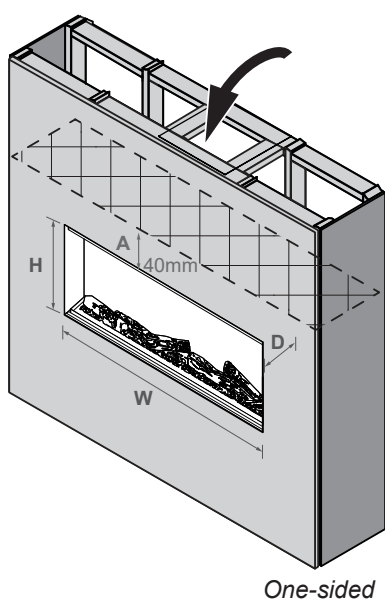

Installation

Glass removal - accessing the parts

To gain access to the various components required for installation follow the below steps to remove the glass panel on the front of the appliance.

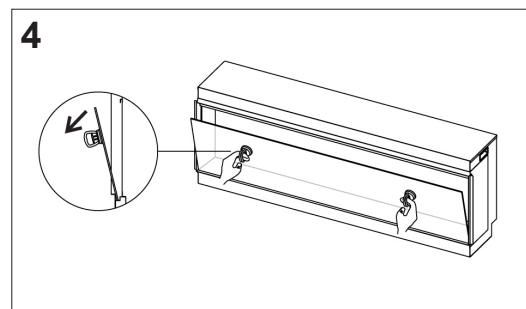
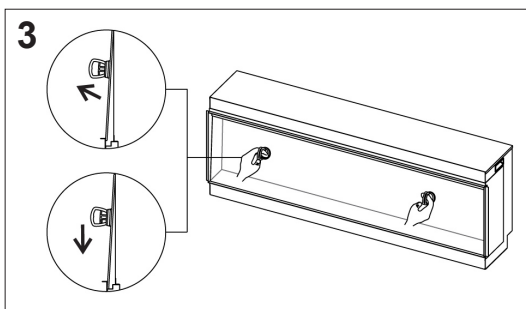
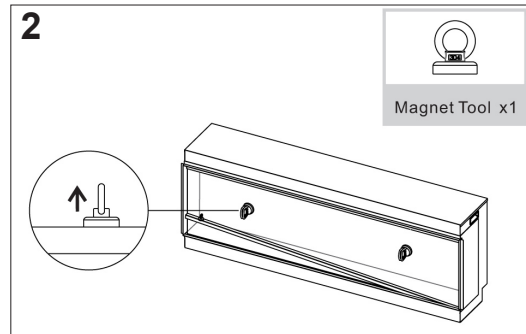
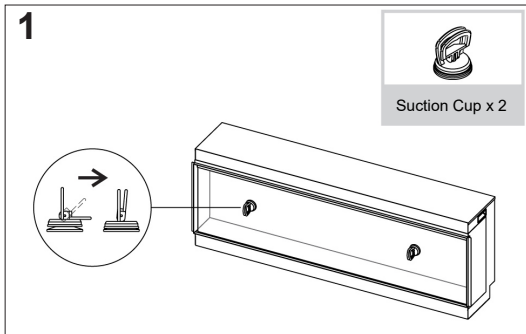

Removing the wall mounting bracket

The wall mounting bracket is secured to the rear panel of the appliance. Remove the screws and the wall mounting bracket and put aside for later use.

Power cord

After inserting the power cord into the socket on the bottom right side of the appliance, secure in place using the power cord securing bracket and ST4*8 screws (found in box 1). If not secured the connection can become loose during installation which may present a sparking hazard.

- Ensure the power cord is not squashed, kinked, or in contact with hot or sharp appliances
- Do not route the power lead in front of the appliance

Wall mounting bracket

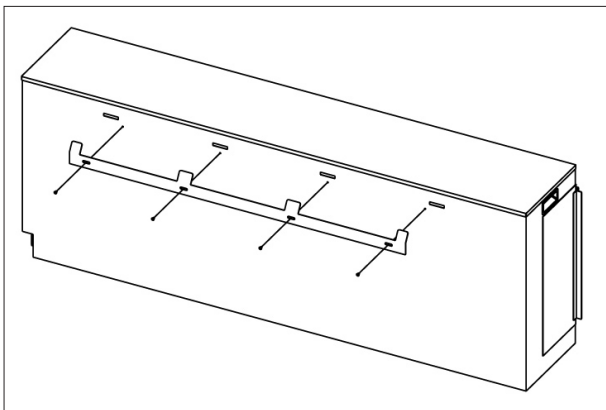

Power cord

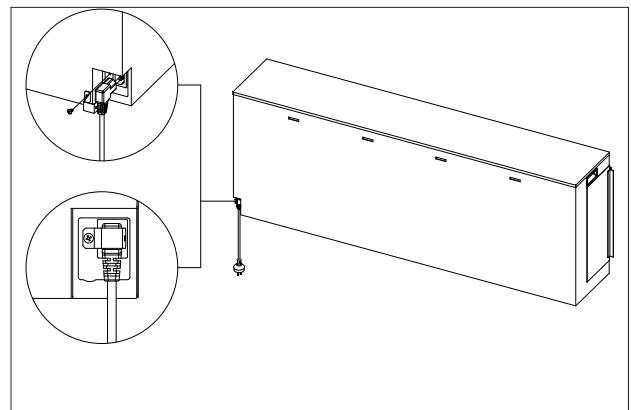

Installation configurations

The appliance can be installed in three configurations:

- Front facing only - one glass panel
- Corner - two glass panels
- Three-sided - three glass panels

Front facing

The appliance will arrive in a singled-side (front only) aspect with the metal side panels already fitted.

Two-sided (corner)

For a two-sided (corner) aspect, choose which side you want to feature a glass panel and remove the seven screws that secure the metal side panel to the appliance (refer two-sided a below).

Carefully remove the panel and keep the screws in a safe place. Using the removed screws, take two top/bottom side glass edge trims and one side of the side glass edge trim and screw them to the appliance as shown below in two-sided b.

Three-sided

For a three-sided aspect, repeat the corner aspect procedure on the opposite side of the appliance.

Front facing

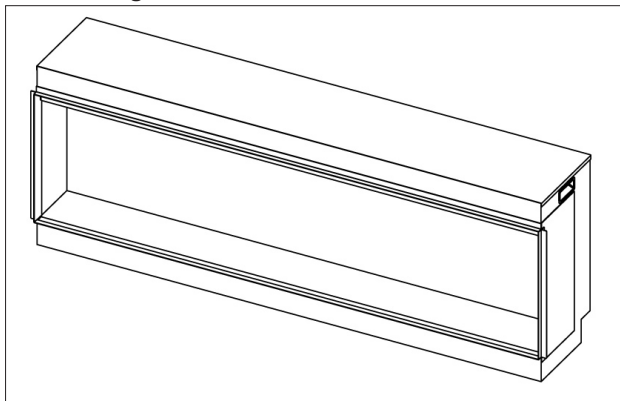

Two-sided - a

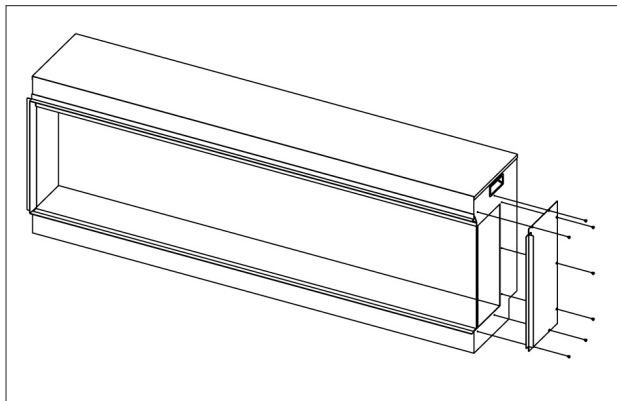

Two-sided - b

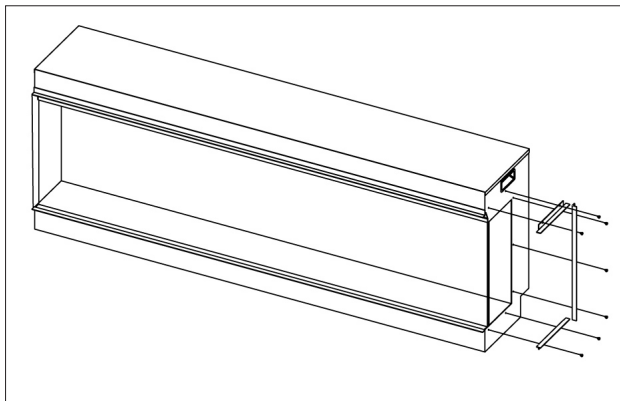

Three-sided

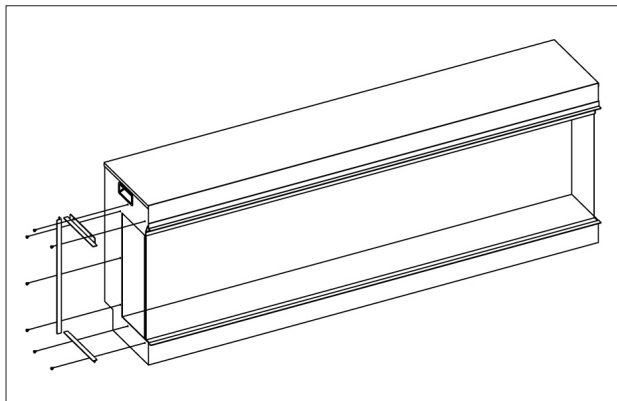

Installation fixing options



Rinnai does not accept any liability for any injuries or damages that may occur due to improper handling or installation. Ensure that the wall where the appliance is to be installed and any wall fixings used are sufficiently strong enough to hold the weight of the appliance. The appliance weight can be found printed on the packaging.

Plasterboard alone is not considered a structural material, do not rely solely on plasterboard fittings to support the weight of the appliance.

If the appliance or any structure linked to the appliance is to be fitted to a wall with a timber frame construction, adequate wooden supporting members must be fitted using appropriate fixings. If this is not possible then steps must be taken to strengthen the wall before installation.



Acoustic cushioning

To reduce vibrational noise during operation of the fire, apply self adhesive cushion foam tape around the edge of the back of the fire and on the underside.

Wall mounted

The appliance is supplied with a wall bracket which is secured to the rear of the appliance.

Remove the bracket from the rear of the appliance, place the bracket in the desired position ensuring it is level, mark the fixing points and use appropriate fixings to secure to the wall.

Attach the bottom mounting brackets to the appliance using four ST4 screws. The appliance can then be lifted on to the wall bracket to enable the bottom bracket fixing points to be marked on the wall. Use suitable fixings to secure the bottom mounting brackets to the wall.

Shelf Mounted

The appliance can be fitted using the shelf support brackets. The brackets can be adjusted up or down to suit a range of shelf material thickness from 15-24mm. Once the correct thickness has been set, carefully place the unit onto the shelf.

Feature Wall

Ensure that the stud wall has a supporting header, the weight of the finished wall should not rest on the top of the appliance. The base of the stud work must be able to take the full weight of the appliance. The four small mounting brackets can be fitted to the appliance as shown.

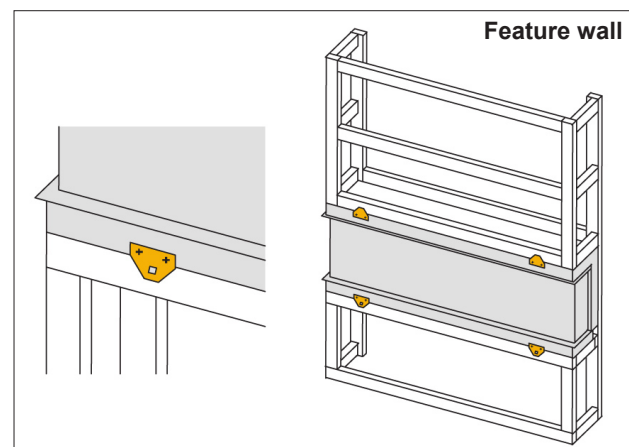
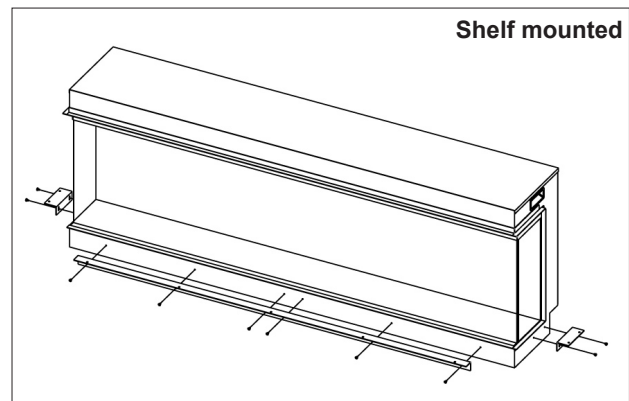
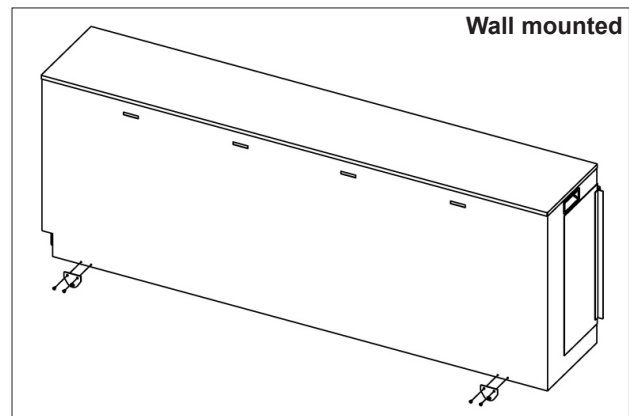

Finishing

Magnetic side decorative panels

The appliance is supplied with two magnetic panels that can be fitted when installing in a two-sided, three-sided, or corner configuration. These panels are positioned against the side of the appliance, behind the side glass edge trim.

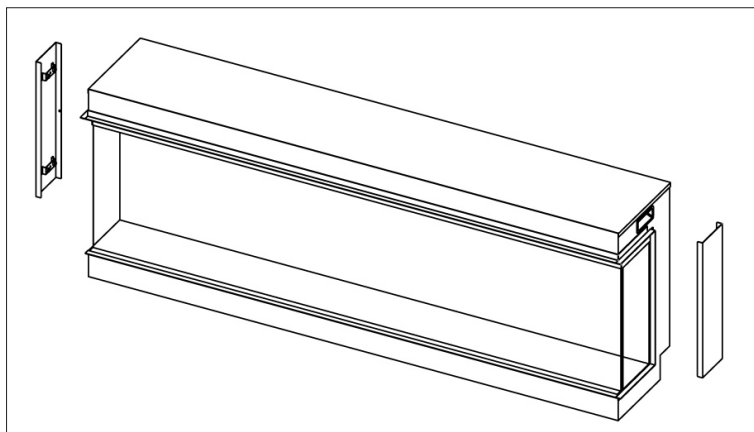

Log and ember arrangement

The logs can be arranged freely on the fire. For the best results it is recommended to position the logs across the fuel bed first; experiment with different angles and overlapping the logs so that some rest on each other.

When you are satisfied with the layout, carefully scatter the glass embers around all the logs. Ensure that all visible areas of the fuel bed, including underneath and behind the logs are covered.

Lastly, in a similar manner, carefully scatter the vermiculite granules over the glass embers ensuring good coverage. Vermiculite will add to the realistic appearance of the flame, it is designed to resemble glowing embers found in traditional wood burning fireplaces.

Log positioning



Glass ember positioning



Vermiculite positioning



Limited Warranty

Rinnai brings you peace of mind with a:



5-year firebox warranty

Rinnai Electric Fires warranty summary

FIREBOX ¹		ALL OTHER PARTS	
Parts	Labour	Parts	Labour
5 years	2 years	2 years	2 years

All terms of the warranty, subject to the conditions below, are effective from the date of first purchase from an authorised Rinnai dealer and/or date of first installation, which can be found on the electrical compliance certificate left by the installer. Proof of purchase will be required at the time of any warranty claim. This warranty is only valid within the country of purchase. Any warranty claim must be made within a reasonable time of discovery of the potential fault or defect.

¹ The firebox is the metal outer casing that surrounds the fire. All other parts of the fire will be covered by a two year limited warranty.

General warranty terms

All Rinnai appliances meet or exceed the safety standards required by New Zealand Electricity (Safety) Regulations. The company is constantly improving its products and as such, specifications are subject to change or variation without notice.

For the purposes of the Consumer Guarantees Act 1993, Rinnai only guarantees the availability of repair facilities and spare parts for the express warranty period recorded in the table above.

This warranty does not limit any consumer rights or guarantees that may apply under the Consumer Guarantees Act 1993. If the product is acquired for the purposes of a business, the provisions of the Consumer Guarantees Act 1993 do not apply and no other warranties (either express or implied by law) apart from those stated in the warranty will apply.

Warranty terms and conditions

1. All Rinnai appliances must be installed, commissioned, serviced, repaired and removed in accordance with the manufacturer's installation instructions, local regulations, and building codes by persons authorised to do so.
2. All appliances must be operated and maintained in accordance with the manufacturer's operating instructions.
3. Servicing / repair of the product is to be carried out by a qualified / licensed electrician.
4. The warranty applies only to the components supplied by Rinnai. It does not apply to components supplied by others, such as electrical switches, electrical cables, fuses, but is not limited to these.
5. Where a failed component is replaced under warranty, the balance of the original warranty will remain effective.
6. Rinnai reserves the right to transfer functional components from defective appliances if they are suitable.

7. Rinnai reserves the right to have installed product returned to the factory for inspection.
8. Where the Electric Fire is installed outside the metropolitan area or further than 40 km from an authorised repairer, travel costs shall be the owner's responsibility.

Warranty exclusions

The following exclusions may cause the warranty to become void and will result in a service charge and cost of parts (if required).

1. Accidental damage, defects or failure caused by acts of nature (fire, wind, lightning, flood, storm, hail storm fallout), vandalism, earthquake, war, civil unrest, pests, animals, insects, or entry of foreign objects or matter into the product such as dirt, debris or moisture.
2. Failure due to abuse or misuse, improper maintenance or improper storage.
3. Failure due to incorrect or unauthorised installations including but not limited to the use of products that are not specified by Rinnai, and damage caused by installation of indoor fires outdoors.
4. Failure or damage caused by alterations, service or repair work carried out by unauthorised personnel.
5. Where it is found that there is no fault with the appliance and the issue is related to the installation or is due to the failure of electricity supplies.
6. Noise caused by minor contraction, movement or expansion of certain parts.
7. Cost of building work to access parts that need repair or replacement, or the costs of building repairs afterwards.
8. Subjective issues such as noise or smell that Rinnai have investigated and are established to be within normal operating parameters.
9. Variances in fireplace appearance, including flame picture, from Rinnai promotional images that are due to printing confines, and on-screen display variances.

Rinnai.co.nz

Tel: 0800 746 624

<http://www.youtube.com/rinnainz>

<http://facebook.com/rinnainz>

Rinnai Electric Fires operation & installation guide 17904-C