

Linear collection gas fireplaces

Flue installation guide

Rinnai

Important

Rinnai Linear gas fireplace flueing shall be installed in accordance with:

- Manufacturer's installation instructions
- Current AS/NZS 3000, AS/NZS 3500, AS/NZS 5601.1 and G12/AS1

Must be installed, commissioned and serviced by an authorised person, being in New Zealand a licensed gasfitter.

The Linear must be installed with an approved flue system, approved components are shown in this guide.

Warning

Improper installation, adjustment, alteration, service and maintenance can cause property damage, personal injury or loss of life.

For more information about buying, using, and servicing of Rinnai appliances call: 0800 RINNAI (0800 746 624).

Rinnai New Zealand Limited
105 Pavilion Drive, Mangere, Auckland
PO Box 53177, Auckland Airport, Auckland 2150

Phone: (09) 257 3800
Email: info@rinnai.co.nz
Web: rinnai.co.nz
[youtube.com/rinnainz](https://www.youtube.com/rinnainz)
[facebook.com/rinnainz](https://www.facebook.com/rinnainz)

Contents

General flueing guidelines	4
Flueing options	6
Air hose connection	9
Flue components	10
Flue component connections.....	11
Side direct flue assembly.....	12
Side extended flue assembly.....	13
Up and back flue assembly	14
Down and out flue assembly	15
Cutting the ASPDFK and ESPIPE900 to length ...	16
Steps to create a wall terminal	17

Appendices

Appendix 1: ESBEND 90°	19
Appendix 2: ESBEND 45°	20

Installer responsibility

Every gas fire requires a flue system that will draw effectively and clear flue products safely under all wind and climatic conditions. It is up to the installer to ensure the appliance is provided with an effective flue.

General flueing guidelines

Flue clearances to combustibles

Due to the heat from the flue components, maintain a 25 mm clearance to combustibles for the first 500 mm of flue.

Flashings

Flashings are not included with the flue kits, these must be specified.

Flue support



The weight of the flue system must not be supported by the appliance, it must be self-supporting. Supporting the flue is usually completed during the framing stage with flue supports or straps within the cavity. Wall straps are included with most Rinnai flue components.

Securing the flue



To prevent the flue from moving or coming apart:

- Joints between the flue components **MUST BE** secured by short screws¹ (max. length 6 mm) through the outer pipes (easier to undo if necessary).
 - Flue components must be secured to the wall using the flue straps provided in each flue kit, refer image above.
-

Lubricate o-ring seals before connecting

The inner pipe joints are sealed with an o-ring seal lubricant. A small plastic tub of silicone grease is provided with the main flue kits. Use this silicone grease to lubricate the o-rings on the inner pipes prior to assembly. This is important as o-rings can dry out and break, and replacing o-rings is difficult.

Do not use petroleum based lubricants as these will cause deterioration of the o-ring seals.

Flue sections located outside

Sections of the flue located outside require the following:

- Only use PVC cement between the joints of the outer PVC pipes to secure and seal the joints against ingress of dust and water.
 - Only use non-acidic silicone sealant between the joints of the outer PVC pipe and any mating aluminium components to seal the joints against ingress of dust and water. Silicone containing acetic acid or other acids as the curing agent may cause the aluminium to corrode.
-

Shared flues

Gas appliances must not be connected to a chimney or flue serving a separate flue burning appliance.

Condensate

A condensate trap or drain is not required for Linear installations as little or no condensate is produced, as the flue runs hotter in Linear installations.

¹ Screws must not touch the inner pipe—could cause a transfer of heat to the plastic outer and potentially melt the plastic.

2° fall to the horizontal flue terminal

There must be a continuous fall of at least 2° to the horizontal wall termination. This is so any rain water exits the flue naturally.

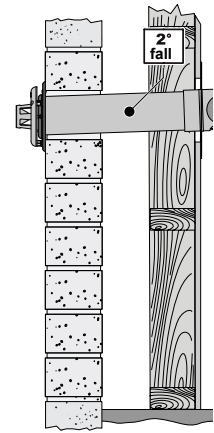

Flue terminal locations

Flue terminals must be compliant with the flue terminal locations shown in AS/NZS 5601.1.

- The flue terminal must be positioned away from any flammable materials.
- Keep snow and other items, such as outdoor furniture well clear of the flue terminal at all times.

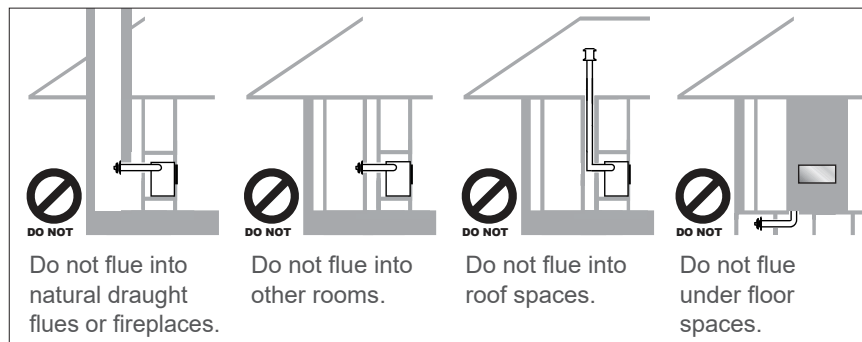

To ensure products of combustion are cleared, adequate clearance from the building is required. The vertical cowl should have a 500 mm clearance from any part of the building. This also applies to steeped and pitched roofs, where the flue cowl should be 500 mm clear of the ridge line.

An adequate flow of fresh air must exist around the flue cowl following installation.

Minimum clearances are shown in AS/NZS 5601.1.

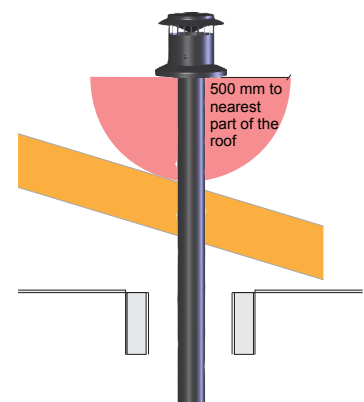

Flueing options



For lowest cost, optimal performance, ease of installation and servicing, Rinnai recommend short flue installations (less than 3 m) are considered before all other options. Short flue installations are shown below.

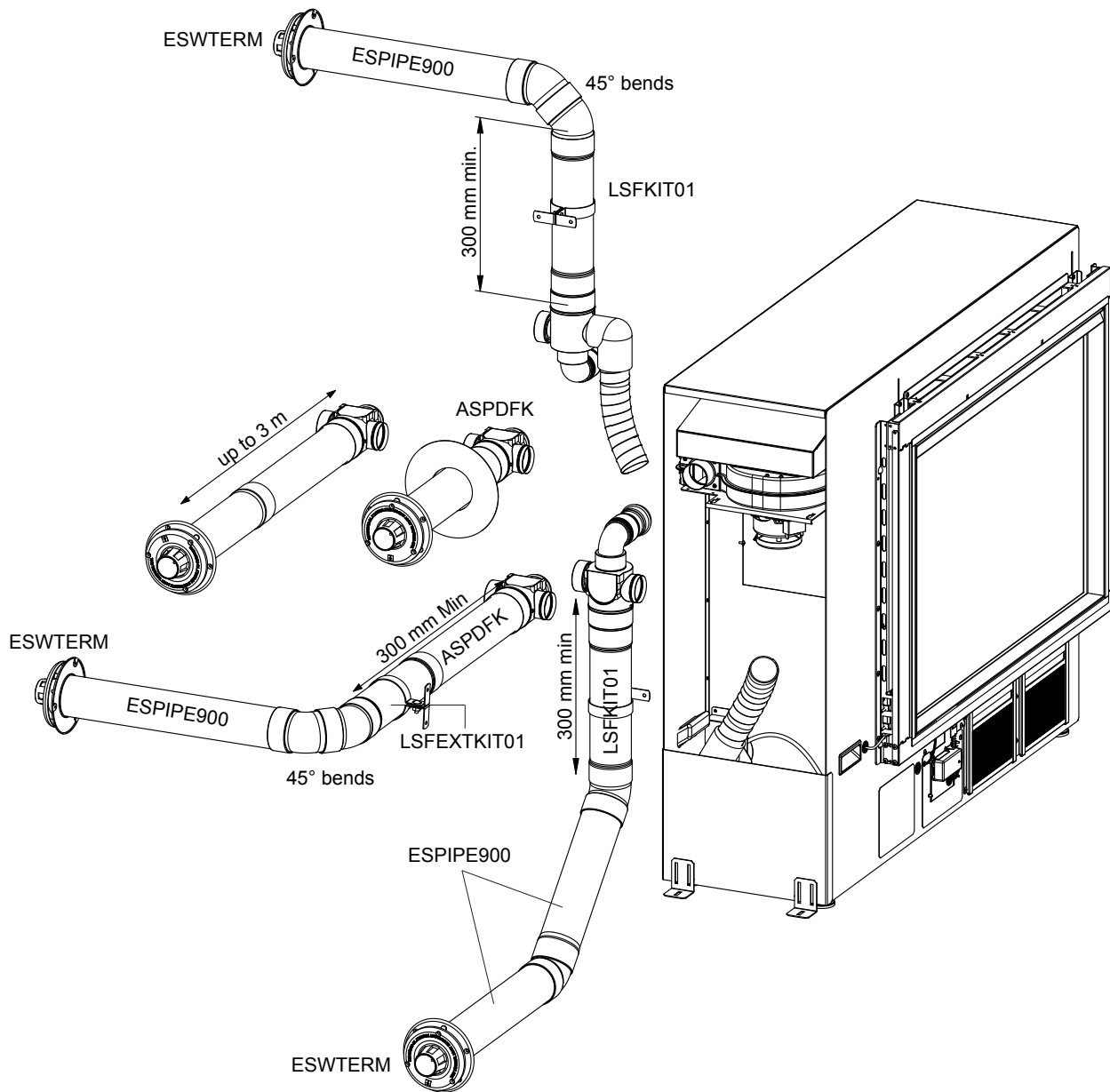

The gas pressures of the Linear are factory set for long flue installations (greater than 3 m). Installations less than 3 m are short flue installations and will require a dip switch change, refer commissioning instructions.

When considering the location of the fire care must be taken to ensure the flue path is free from obstructions such as studs, noggins, joist, braces, electrics etc.

Maximum flue length and number of bends

Maximum flue length = 8.5 m
Maximum number of bends = three

For every 90° bend, the overall length must be reduced by 1 m. For example, if an installation has three 90° bends, the maximum flue length can be 5.5 m. The elbow component of the Linear adaption flue kit (LSFKIT01) is **not** counted as a 90° bend.

300 mm of straight flue before any bends

A minimum of 300 mm of straight flue is required before any bends. This is required due to the heat produced from the initial section of flue. The LSFKIT01 has the 300 mm minimum flue length built in.

If using the direct flue (ASPDFK) and connecting to any bends, a flue transition extension (LSFEXKIT01) must be connected to achieve the minimum length.

Side direct, sided extended, side and back flueing

Side direct through the wall flueing for walls up to 385 mm thick. Flue can be extended if the wall thickness is greater than 385 mm by using additional lengths of flue pipe, and the pipe can be directed behind by using the flue transition extension and bend kit.



1. Direct flue kit - ASPDFK

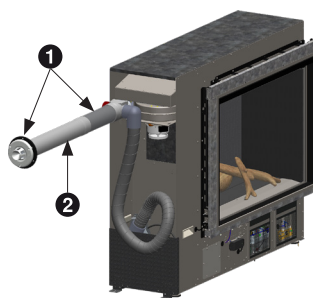

1. Direct flue kit - ASPDFK
2. Flue pipe - ESPIPE900

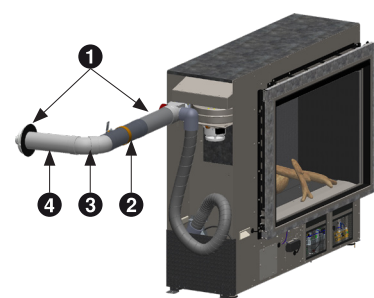

1. Direct flue kit - ASPDFK
2. Flue transition - LSFEXKIT01
3. 45° bends - ESBEND
4. Flue pipe - ESPIPE900

Back direct and back extended flueing

By changing the direction of the adaption flue position and connection, back direct and back direct extended flueing is possible.

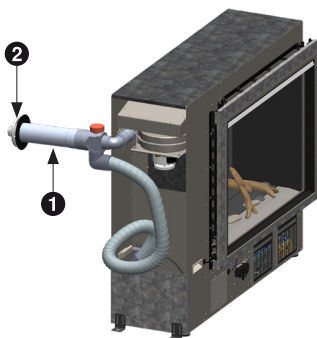

1. Adaption flue - LSFKIT01
2. Wall terminal - ESWTERM

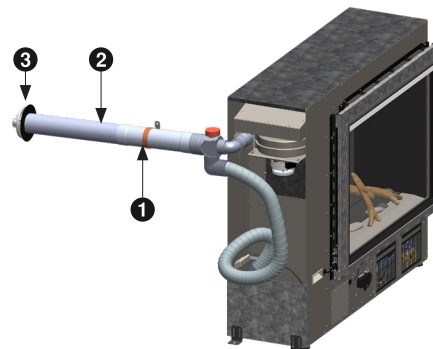

1. Adaption flue - LSFKIT01
2. Flue pipe - ESPIPE900
3. Wall terminal - ESWTERM

Flueing options continued

Up and back, and up and over flueing

Up and back through the wall flueing for walls up to 385 mm thick. Flue can be extended if the wall thickness is greater than 385 mm by using additional lengths of flue pipe.

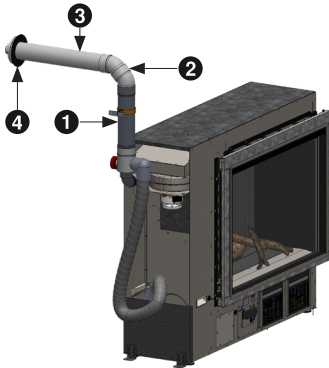

- 1. Adaption flue - LSFKIT01
- 2. 45° bends - ESBEND
- 3. Flue pipe - ESPIPE900
- 4. Wall terminal - ESWTERM

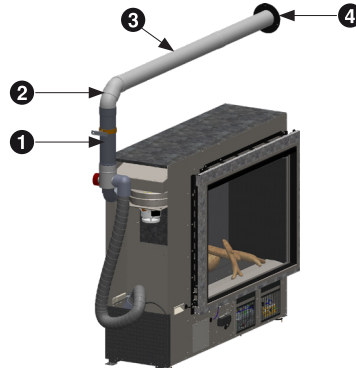

- 1. Adaption flue - LSFKIT01
- 2. 45° bends - ESBEND
- 3. Flue pipe - ESPIPE900 x 2
- 4. Wall terminal - ESWTERM

Down and out flueing

The down and out flue allows for the adaption flue to face downwards, and for the flue to run vertically through a hole in the floor, and then to terminate horizontally outside.

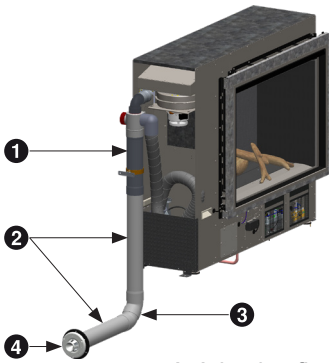

- 1. Adaption flue - LSFKIT01
- 2. Flue pipe - ESPIPE900 x 2
- 3. 45° bends - ESBEND
- 4. Wall terminal - ESWTERM
- 5. Wall plate - ESPLATE (not shown)

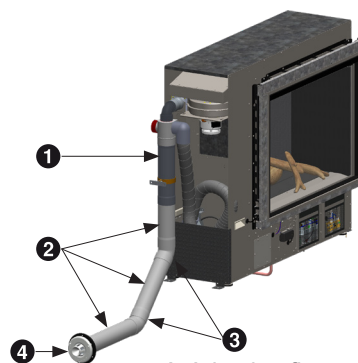

- 1. Adaption flue - LSFKIT01
- 2. Flue pipe - ESPIPE900 x 3
- 3. 45° bends - ESBEND
- 4. Wall terminal - ESWTERM
- 5. Wall plate - ESPLATE (not shown)

Vertical flueing

The vertical in-wall flue installation is installed against an internal wall or other suitable cavity, and is run vertically upwards to a vertical termination above the roof.

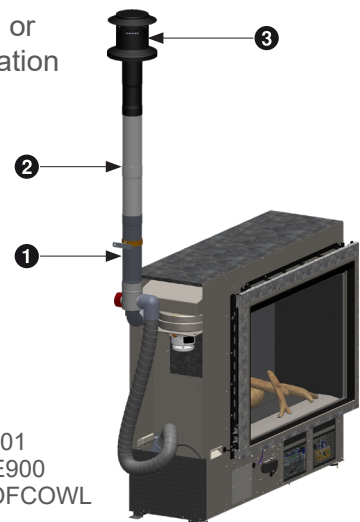

- 1. Adaption flue - LSFKIT01
- 2. Flue pipe - ESPIPE900
- 3. Vertical terminal - ESROOFCOWL

Air hose connection



This step in the installation is critical. If the connections are not secured properly, products of combustion could disperse into the room being heated.

The Linear comes with one end of the flexible air hose already connected to the Linear air inlet. Attach the other end of the air intake hose to the connection on the flue, either the ASPDFK or the LSFKIT01.

Connect the flue into the Linear combustion fan exhaust, and secure in place (two screws) with the flue lock bracket (supplied in the plastic bag with the remote control).

Secure the air intake hose on the flue with the cable tie (supplied in the plastic bag with the remote control), and ensure the rubber cap is in place on the unused air intake.

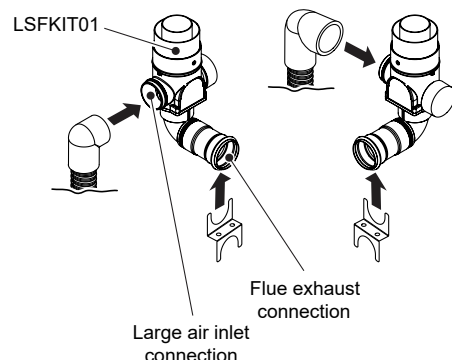
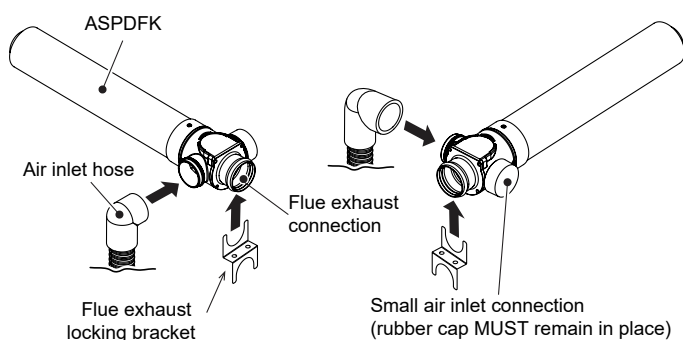
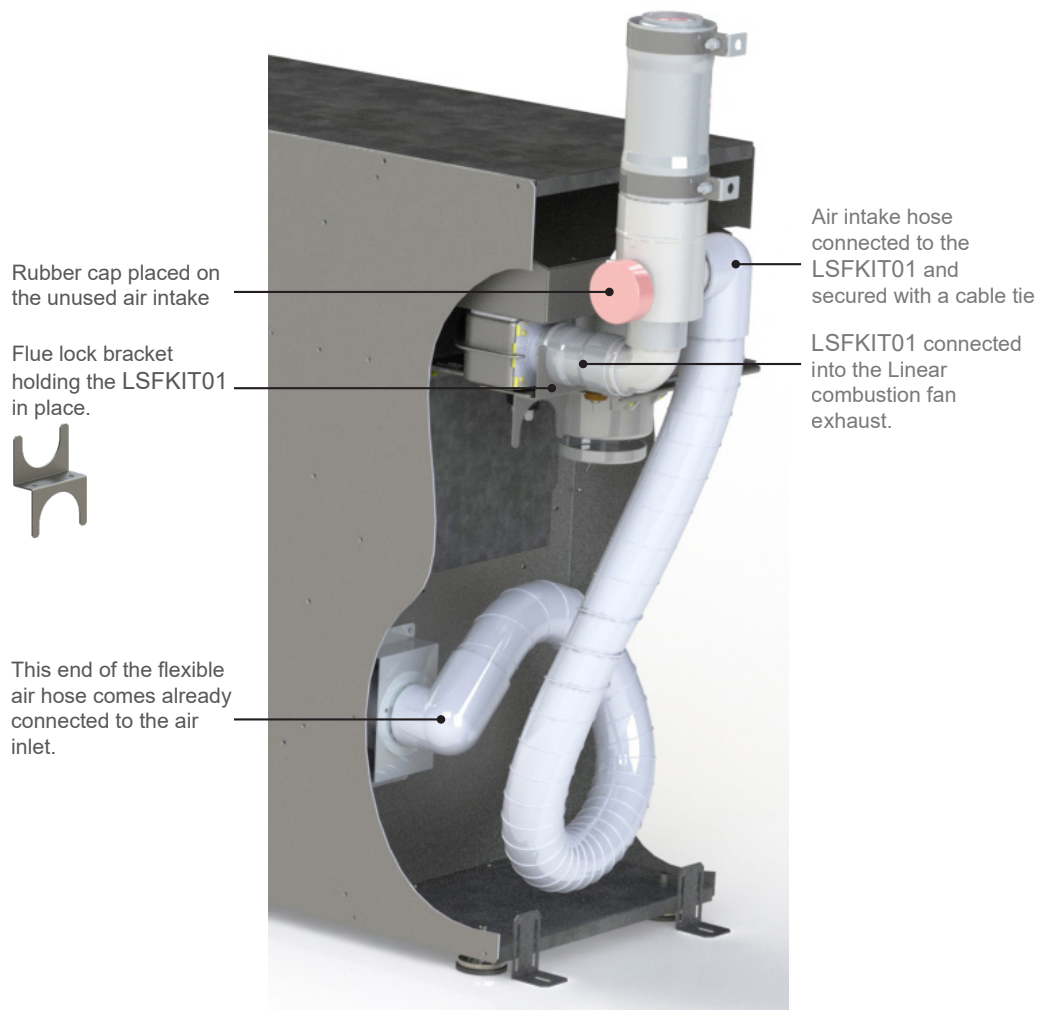

Flue components

Due to heat from the flue components, maintain 25 mm clearance to combustibles for the first 500 mm of flue

Direct flue kit - ASPDFK (aluminium)

Suitable for walls up to 385 mm thick (can be cut to length). Can also be used with ESPIPE900 for longer flueing. The minimum length when measured from the back plate of the transition casting MUST NOT be less than 300 mm when joining to other components.

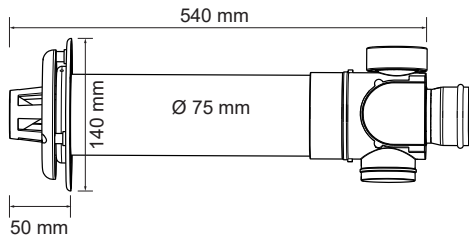

Not pictured is the internal white wall plate

Adaption flue kit - LSFKIT01

Includes flue adaptor, flue extension, standoff bracket, flue slide stopper (4822), O-ring silicone grease.

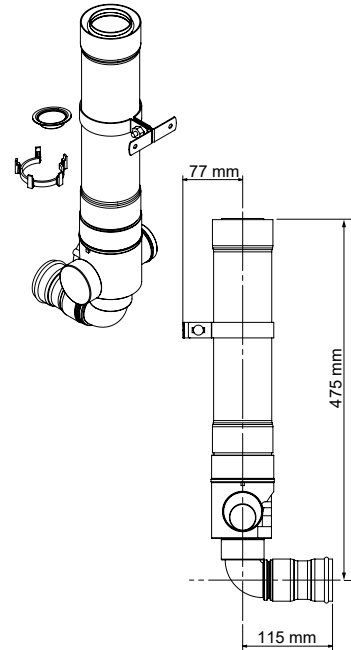

45° flue bends - ESBEND

Two bends in a kit. Can be used separately, or together as a 90° bend. Refer additional images on p.19-20.

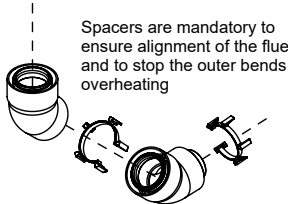

Wall terminal kit - ESWTERM

Used to terminate the ESPIPE900 in horizontal flue installations when used with LSFKIT01.

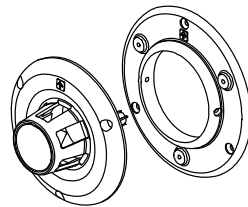

Flue pipe - ESPIPE900

Extension pipe used for horizontal, vertical, and downwards flueing. Can be cut to size at the non-socketed end.

Inner is aluminium, outer white PVC. Comes with a wall bracket, o-ring (4350), and spacer (4351).

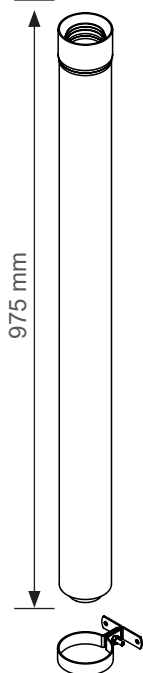

Roof terminal - ESROOFCOWL

Roof cowl and connecting pipe for termination of a vertical flue—can be cut to size. 500 mm clearance required from any part of the building, refer p.5.

Galvanised steel, powder coated black.

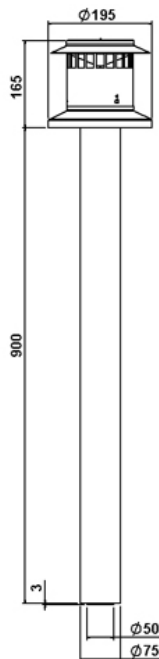

Transition extension - LSFEXTKIT01

Flue transition extension, MUST BE used with the ASPDFK before any bends, for example in side and back flueing. When connected overall length reduces 45 mm each end.

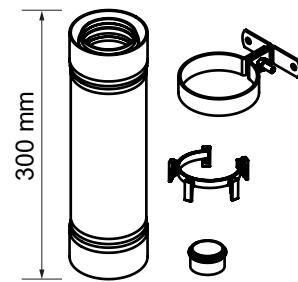

Wall plate - ESPLATE

Used in down and out flueing to cover the floor penetration, and also as an extra wall cover if required, to tidy up an installation. Outer diameter 170 mm.

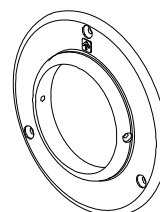

Flue component connections

Adaption flue kit, and flue transition extension

The LSFKIT01 and LSFEXTKIT01 are the same at each end—either end can be connected.

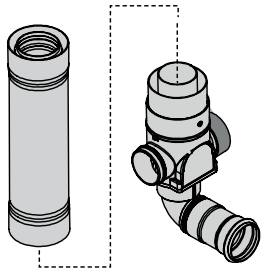

Flue pipe (ESPIPE900)

The socket end of the pipe containing the o-ring connects to the non-socketed end of the previous component. If cutting to connect to another component always cut the non-socketed end, never discard the socket o-ring end.

Socket (o-ring) end
(do not cut)

Non-socket end
(can be cut)

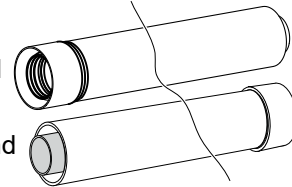

Connecting the 45° bends (ESBEND)

If installed incorrectly there is potential for the outer bend to overheat. The centering spacer is a mandatory component that is required for the correct alignment of the flue components when bends are used. When fitted correctly the inner and outer pipes of the ESBEND will be self centering.

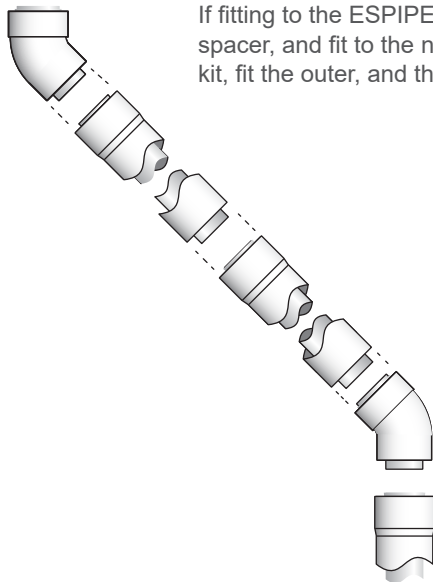

If fitting to the ESPIPE900, lubricate the socket o-ring end of the pipe, the end with the black spacer, and fit to the non-socket end of the bend. Fit the white spacer provided in the ESBEND kit, fit the outer, and then repeat if adding additional components.

Non-socket end

Socket o-ring end

Refer p.19-20 for additional images

Connecting the roof cowl (ESROOFCOWL)

Connect the non-socketed end to the socketed end of the previous component and secure.

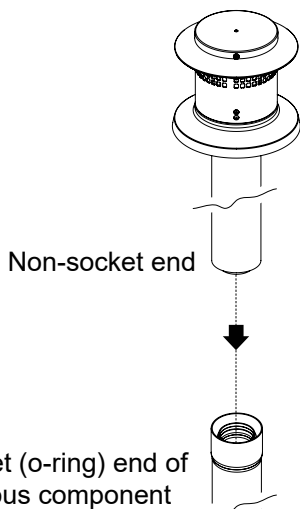

Side direct flue assembly

The direct flue (ASPDFK) is suitable for walls up to 385 mm thick—can be cut to size and the wall terminal reattached.

The flue must terminate 300 mm above ground level.

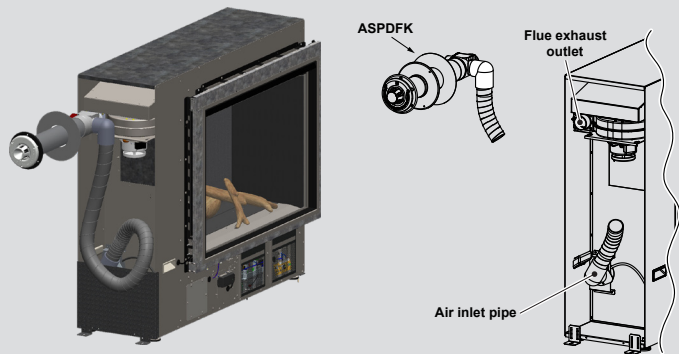

With the Linear installed into the support framing:

1. Create the wall penetration. The minimum diameter required is 80 mm to non-combustible surfaces such as brick, and 100 mm to combustible surfaces such as plaster. Allow for a continuous 2° fall from the Linear to the wall terminal.
2. Slide the internal wall plate over the terminal end of the ASPDFK pipe until it is nested on the raised ring of the flue transition.
3. Pass the ASPDFK through the internal wall penetration.
4. Make the Linear exhaust and combustion air hose connections, refer p.9.
5. Slide the internal wall plate so it is flush with the wall.
6. Create the wall terminal, refer p.17.

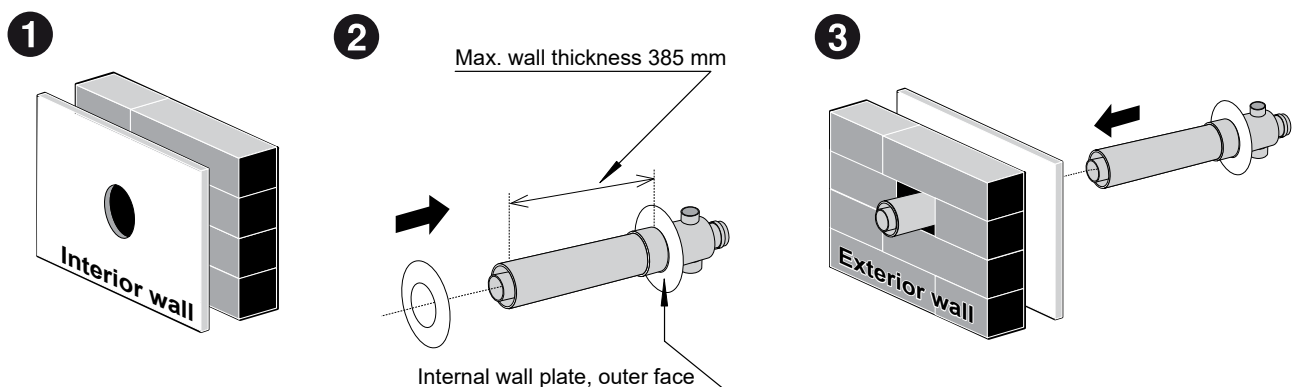

Side extended flue assembly

The direct flue (ASPDFK) can be extended if the wall thickness is greater than 385 mm by using additional lengths of pipe.

The flue must terminate 300 mm above ground level.

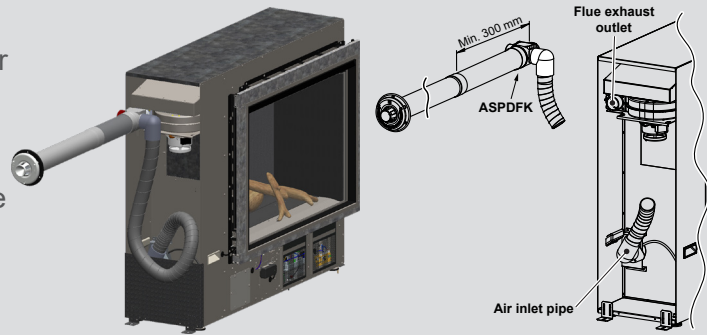

With the Linear installed into the support framing:

1. Create the wall penetration. The minimum diameter required is 80 mm to non-combustible surfaces such as brick, and 100 mm to combustible surfaces such as plaster. Allow for a continuous 2° fall from the Linear to the wall terminal.
2. Join the ESPIPE900 to the ASPDFK, fit additional lengths of flue pipe as required. Components do not require cutting to be joined. If cutting is required to achieve desired length ensure the ASPDFK component is NOT LESS than 300 mm.
3. Slide the internal wall plate over the terminal end of the ASPDFK pipe until it is nested on the raised ring of the flue transition.
4. Pass the flue pipe through the internal wall penetration.
5. Make the Linear exhaust and combustion air hose connections, refer p.9.
6. Slide the internal wall plate so it is flush with the wall.
7. Create the wall terminal, refer p.17.

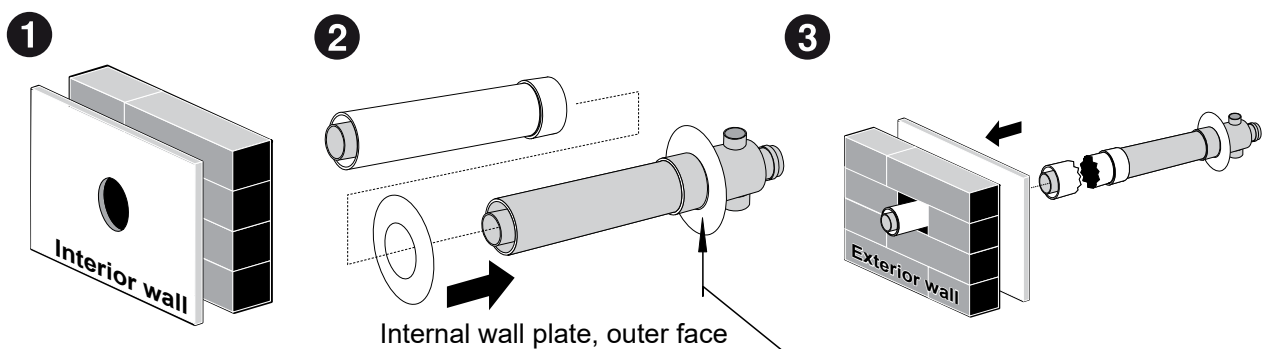

Up and back flue assembly

Up and back through wall flueing for walls up to 385 mm thick. Flue can be extended if the wall thickness is greater than 385 mm by using additional lengths of flue pipe.

A 2° fall is required towards the flue termination. The flue must terminate 300 mm above ground level.

A minimum of 300 mm of straight flue before any bends. This is required due to the heat produced from the initial section of flue, which could melt the outer plastic. The LSFKIT01 has the 300 mm min. flue length built in.

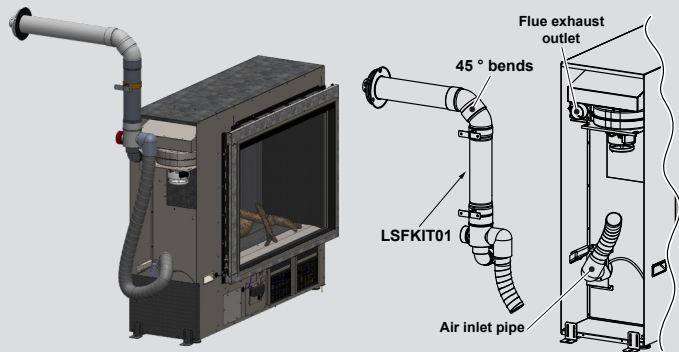

With the Linear installed into the support framing:

1. Assemble the flue components as pictured above. Ensure the flue transition section of the LSFKIT01 is included. NEVER discard this section as this will cause an unsafe installation due to a buildup of heat in the flue.
2. Create the wall penetration. The minimum diameter required is 80 mm to non-combustible surfaces such as brick, and 100 mm to combustible surfaces such as plaster. Allow for a 2° fall to the wall terminal.
3. Pass the flue pipe through the internal wall penetration.
4. Make the Linear exhaust and combustion air hose connections, refer p.9.
5. Create the wall terminal, refer p.17.

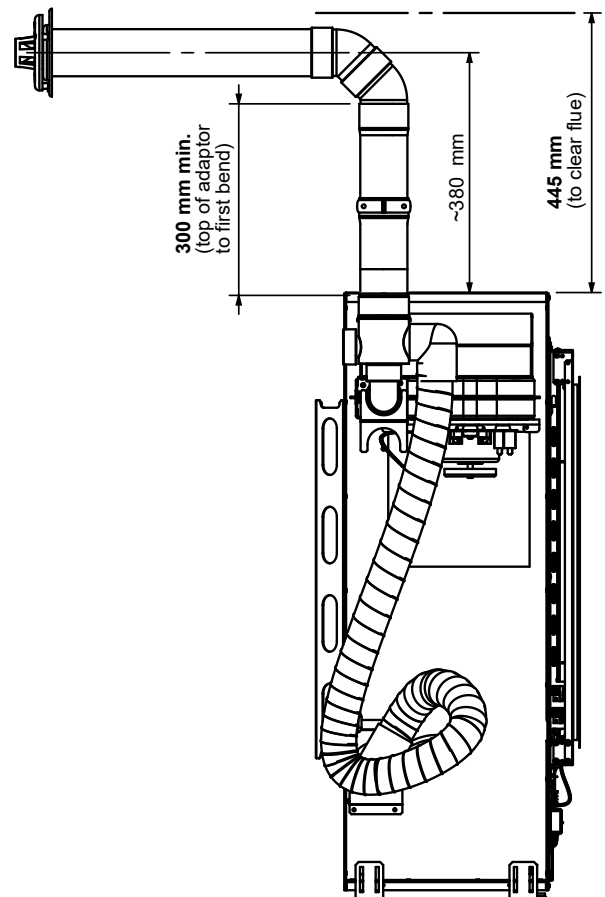

LSFKIT01, flue transition
MUST BE connected

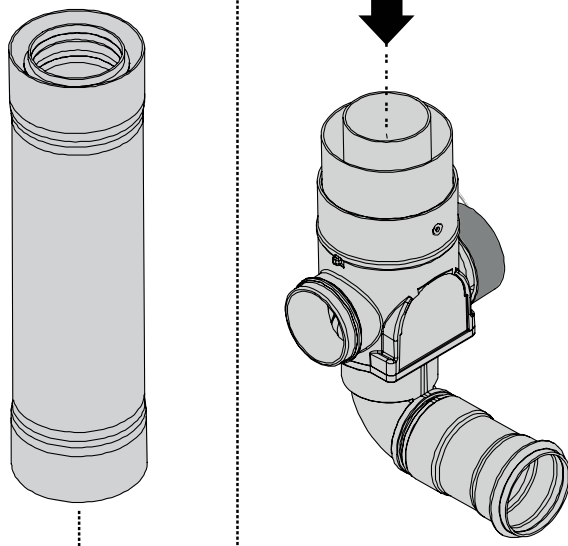

Down and out flue assembly

The down and out flue allows for the adaption flue component to face downwards, and for the flue to run vertically through a hole in the floor, and then terminate horizontally outside—flue must terminate 300 mm above the ground.

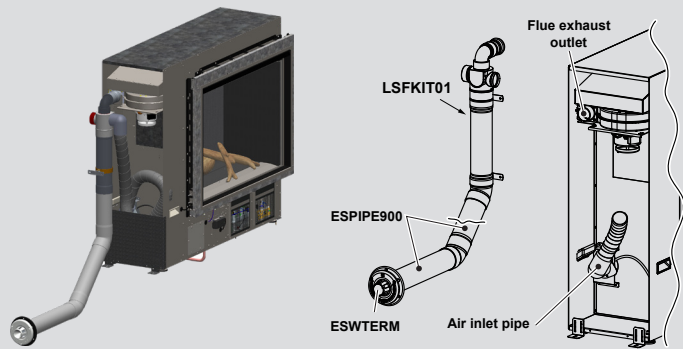

A minimum of 300 mm of straight flue before any bends. This is required due to the heat produced from the initial section of flue, which could melt the outer plastic. The LSFKIT01 has the 300 mm min. flue length built in.

With the Linear installed into the support framing:

1. Fit the flue components and lengths of flue pipe as required. Ensure the flue transition section of the LSFKIT01 is included. NEVER discard this section as this will cause an unsafe installation due to a buildup of heat in the flue.
2. The flue penetration should be made at the same time as the cutout for the gas connection. The floor penetration minimum diameter is 80 mm to non-combustible surfaces such as brick, and 100 mm to combustible surfaces such as plaster.
3. Pass the flue pipe through the internal wall plate and through the floor penetration, and secure the wall plate in place to seal the floor.
4. Prepare the horizontal section of the flue system under the floor by connecting the flue pipe and bends as required. Allow for a 2° continuous fall from the first section of the horizontal flue pipe to the wall penetration.
5. Create the wall terminal, refer p.17, ensuring a 300 mm clearance between the flue terminal and ground level.

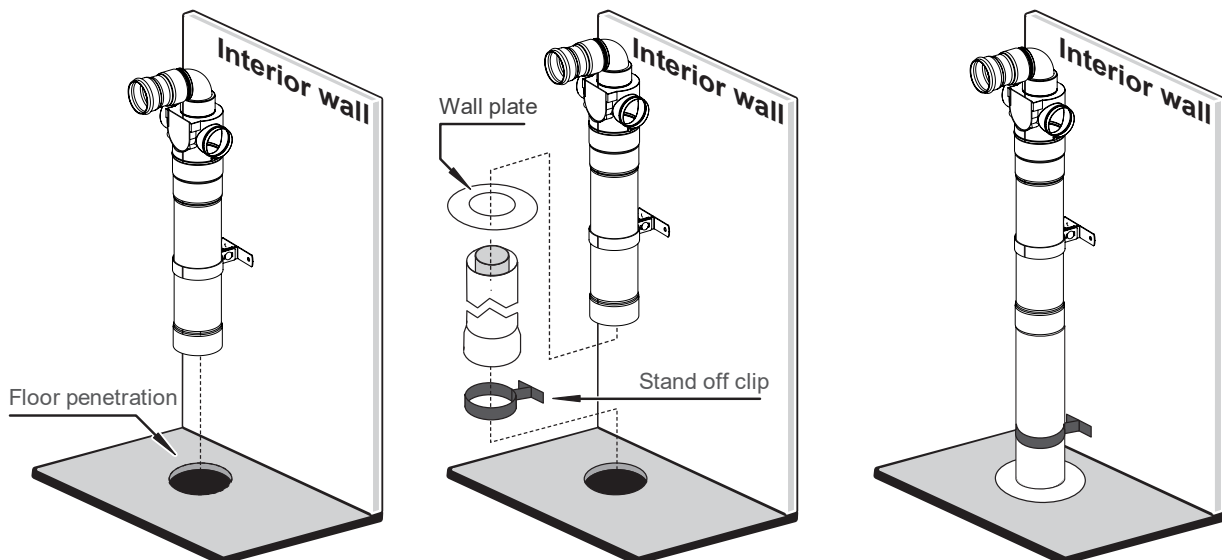

Cutting the ASPDFK and ESPIPE900 to length to connect to another part

Cutting the ASPDFK or ESPIPE900 may be needed to achieve the required flue length to connect to another component.



- The minimum length of the ASPDFK when measured from the back plate of the transition casting **MUST NOT** be less than 300 mm when joining to other components.
- Ensure all burrs and swarf are removed from any cut ends.
- ESPIPE900 can be cut to size at the non-socketed end

Cutting components to achieve the desired flue length

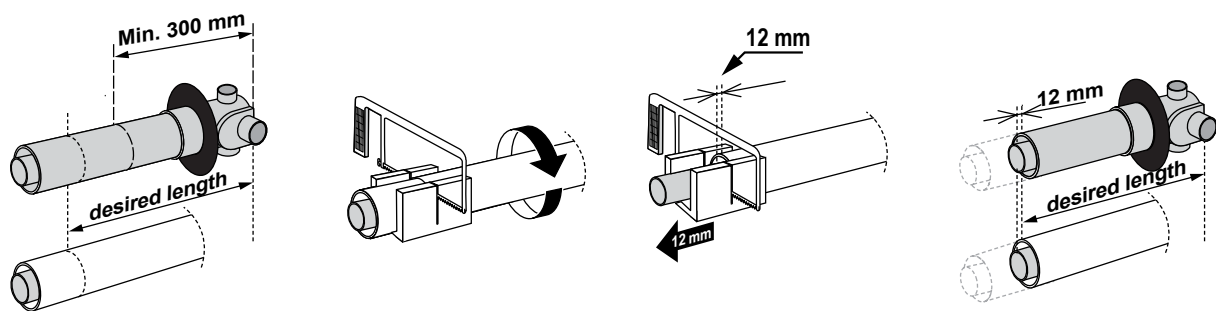

1. Measure and mark off the outer pipe at the desired length.
2. Cut the outer pipe to the required length. Take care not to cut the inner pipe.
3. From the new end of the outer pipe measure and mark off an additional 12 mm on the inner pipe. Cut the inner pipe at this mark. Take care to keep the cut parallel to the outer pipe.

The additional 12 mm shown in the diagram above is required to allow the component to be joined to another part.

Steps to create a wall terminal

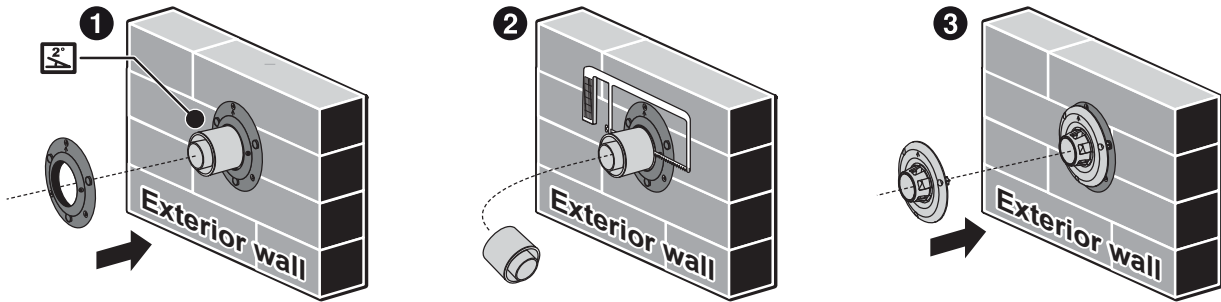

1. Fit the supplied external wall plate over the outer pipe of the flue protrusion (arrow points up)

Once the external wall plate is in the correct position secure it to the wall using the three 22 mm screws into the wall plate holes. Secure the wall plate to the outer pipe using the two horizontal holes and the two 7 mm screws provided.

2. Carefully cut through the outer and inner pipes **ensuring the inner and outer are flush with the external wall plate** as shown below. Take care to avoid cutting the external wall plate, and keep the cuts of the internal and external pipes as parallel as possible. Remove all burrs and swarf from the cut ends.

3. Align the arrows of the metal flue terminal and wall plate to point in the same direction (must always point up) and screw the terminal to the external wall plate using the 22 mm screws into the holes provided.



2° fall to the outside—
arrow points up

Images showing how final terminal should be installed

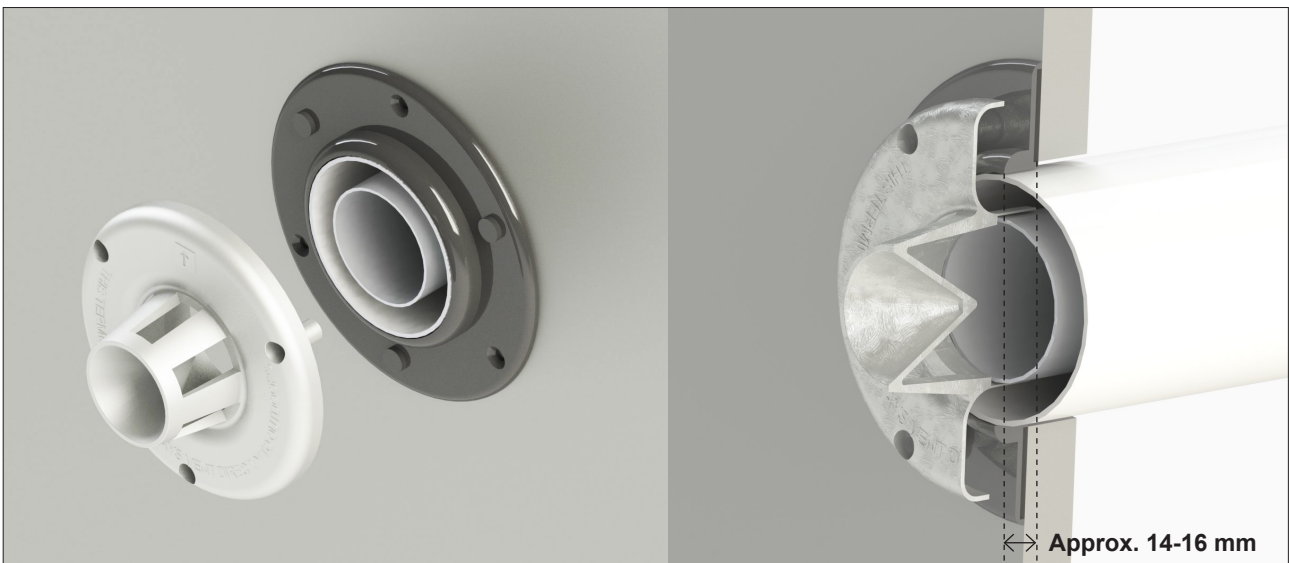

Please note: The flue protrusion from the wall is approx. 14-16 mm. It must not be more than this as it will create a gap between the flue and the wall terminal, which will cause operational issues.

Appendix 1: ESBEND 90°



Appendix 2: ESBEND 45°

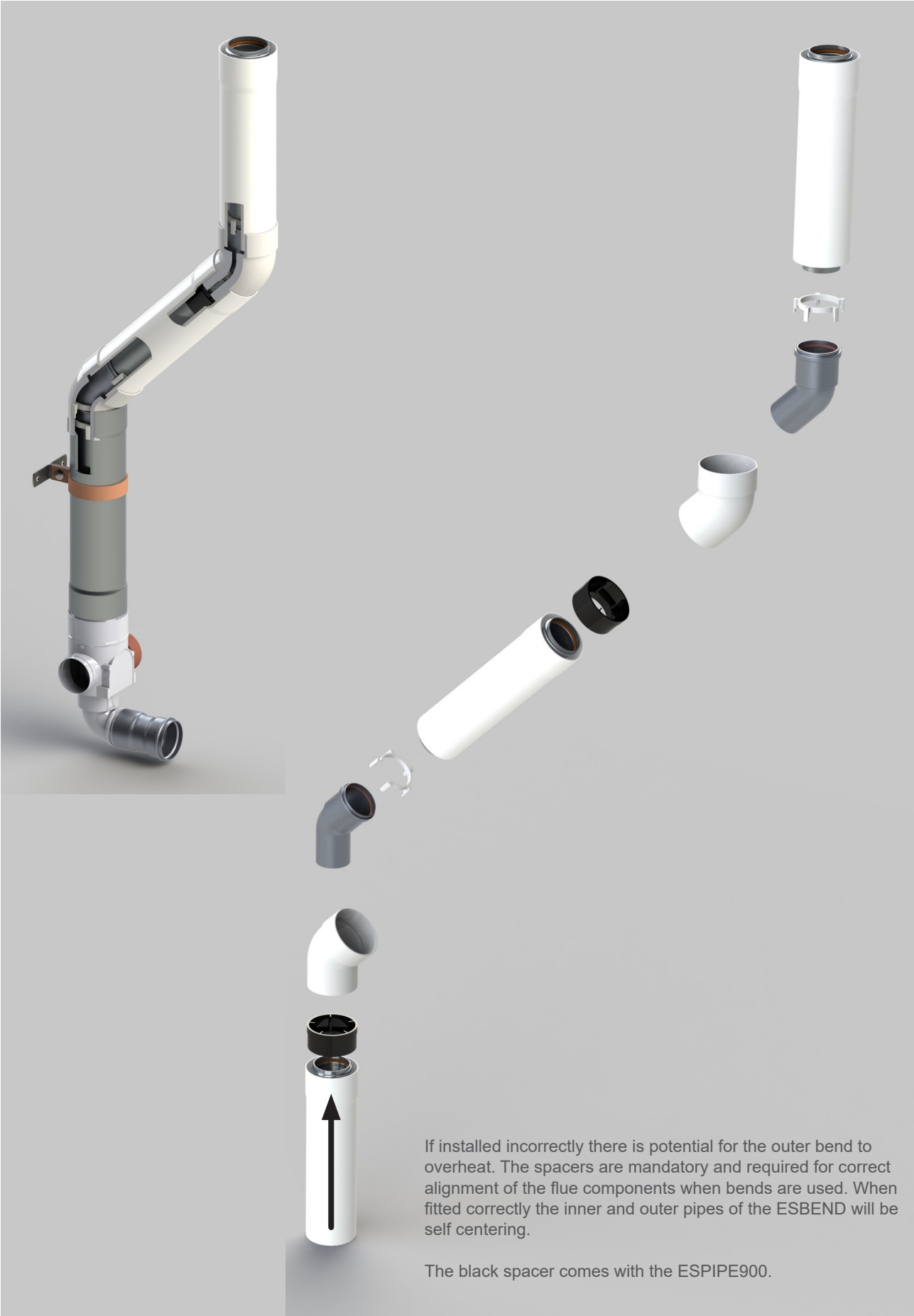

Rinnai.co.nz

Tel: 0800 746 624
<http://www.youtube.com/rinnainz>
<http://facebook.com/rinnainz>

Linear flue install guide 13541-B