

Pro Series Ducted 15 kW indoor unit (DINLR15B1)

This diagram is provided to assist you to identify parts if replacement is necessary. Contact your place of purchase or the manufacturer to enquire about parts, availability and/or service.

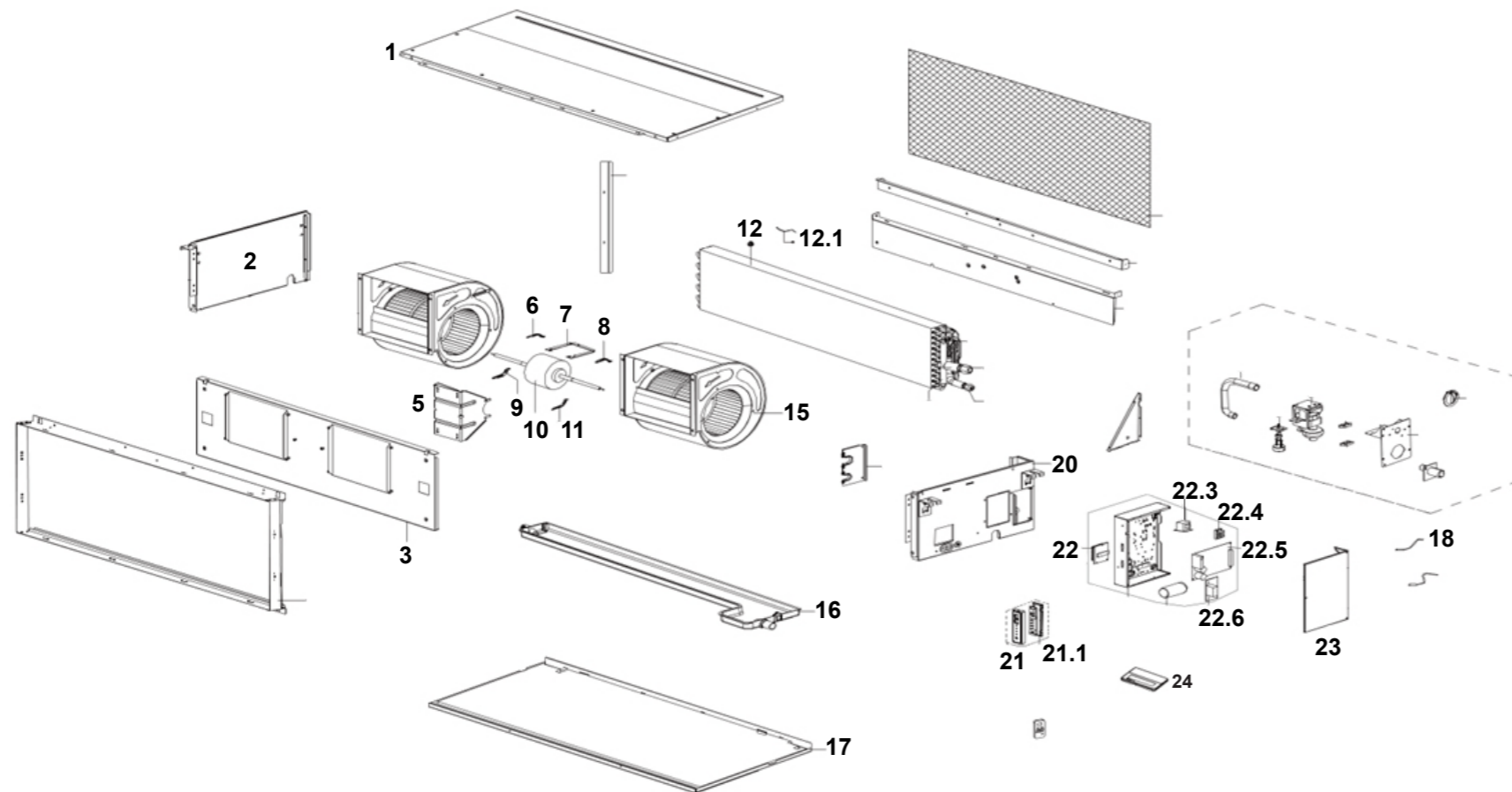

Ref.	Description	Part No.
1	Top cover assembly	
2	Left side plate assembly of cabinet	
3	Front clapboard assembly	
5	Fan motor support	
6	Fan motor cover	
7	Fan motor fixing board	
8	Fan motor cover	
9	Fan motor cover	
10	Brushless DC motor	14199
11	Fan motor cover	
12	Evaporator assembly	
12.1	Pipe temperature sensor	14201
15	Fan assembly	
16	Water collector assembly	
17	Chassis assembly	
18	Room temperature sensor	14202
20	Right clapboard assembly	
21	Duct display board sub-assembly	84000085
21.1	Duct display board sub-assembly	
22	Duct electronic control box sub-assembly	
22.3	Reactor	
22.4	Terminal	
22.5	Duct main control board sub-assembly	
22.6	Inverter module sub-assembly	
23	Cover of electronic control box	
24	Wired controller	

Pro Series Ducted 15 kW outdoor unit (DONSR15B1)

This diagram is provided to assist you to identify parts if replacement is necessary. Contact your place of purchase or the manufacturer to enquire about parts, availability and/or service.

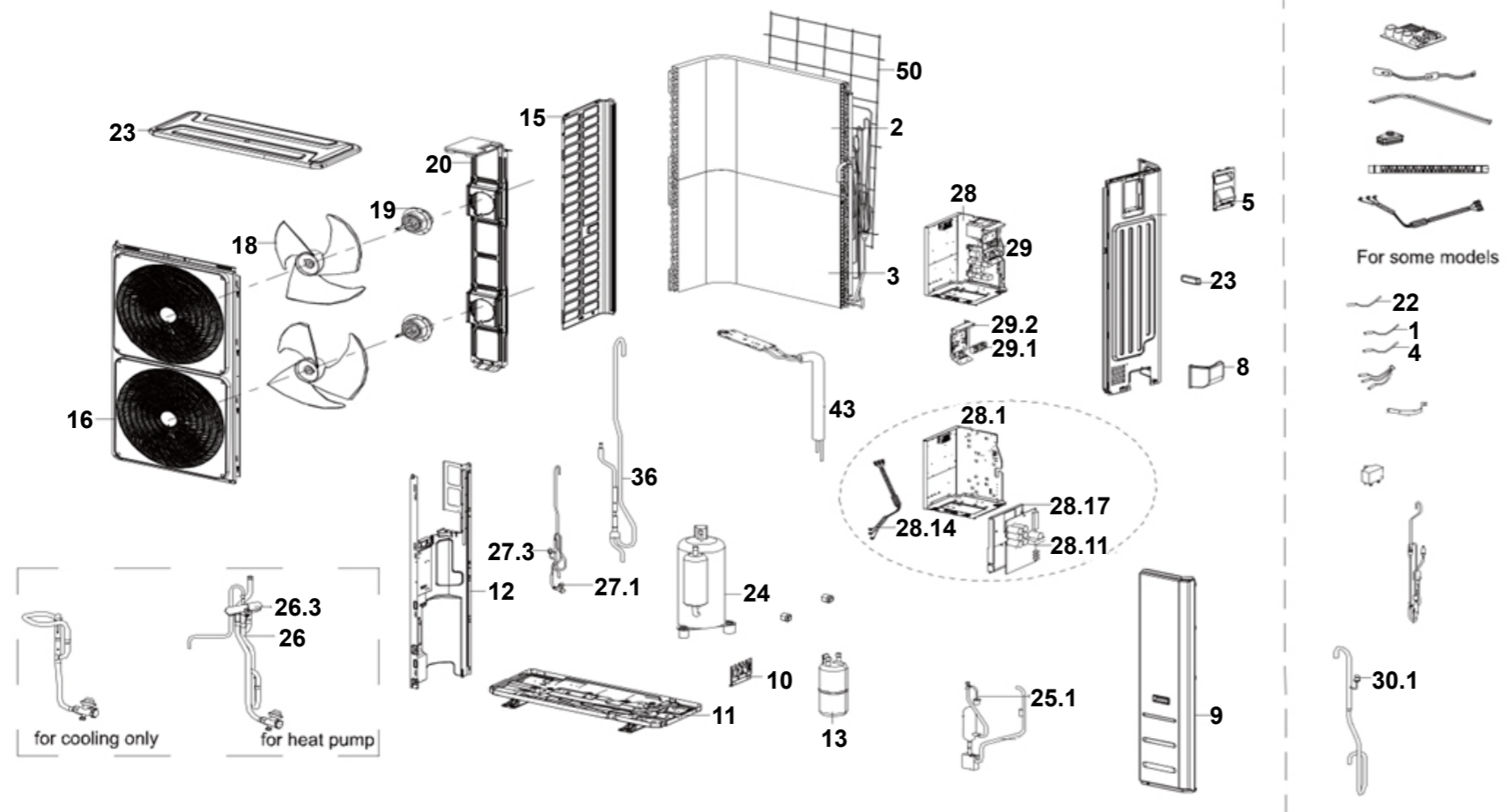

Ref.	Description	Part No.
11	Chassis assembly	
12	Partition board assembly	
13	Liquid storage tank	
15	Left side plate assembly of cabinet	
16	Air outlet grille	
18	Axial flow fan	
19	Brushless DC motor	14204
20	Fan motor support sub-assembly	
22	Discharge temperature sensor	14159
23	Top cover assembly	
24	DC inverter rotary assembly	
25.1	Pressure switch	
26	4-way valve assembly	
26.2	Gas valve	
26.3	4-way valve	
27	Liquid valve assembly (not shown)	
27.1	Liquid valve	
27.3	Electronic expansion valve	
28	Electronic control box sub-assembly	14208
28.1	Installation plate of electric parts sub-assembly	
28.2	Inverter module sub-assembly	
28.10	Electronic installing box	
28.11	Outdoor main control board sub-assembly	
28.14	Compressor wire sub-assembly	
28.17	Electronic installing box	
29	Terminal board sub-assembly	14209
29.1	Wire joint A	
29.1	Wire joint B	
29.2	Terminal installation sub-assembly	
30.1	Pressure switch	14182
36	Throttle valve sub-assembly	
50	Rear net	

Ref.	Description	Part No.
1	Room temperature sensor	14164
2	Condenser assembly	
3	Condenser assembly	
4	Pipe temperature sensor	14203
5	Big handle assembly	
6	Rear right clapboard assembly	
6.1	Handle	
8	Water collector	
9	Front right clapboard assembly	
10	Valve plate	