

ESHP60

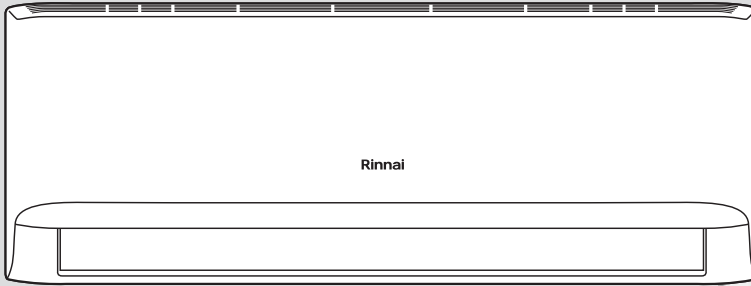

HONRTX60

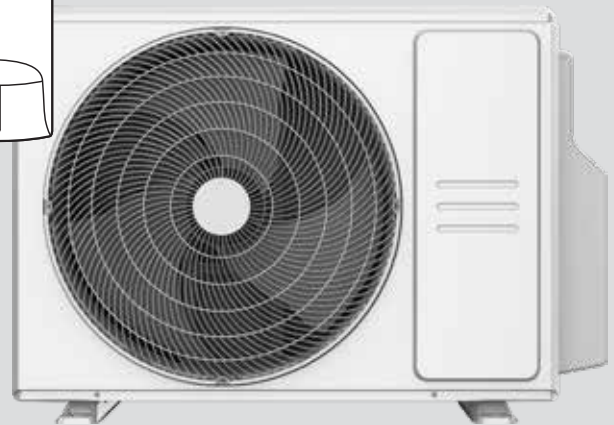

Velare 1500 - Hybrid Electric Fire: Heat Pump System Installation guide

Rinnai

Important

This appliance must be installed in accordance with:

- Manufacturer's installation instructions
- Current AS/NZS 3000, AS/NZS 5141, AS/NZS 5149, AS/NZS 1677, AS/NZS 60335.2.40, and G12/AS1

Appliance must be installed, commissioned, serviced, and removed by an authorised person.

The Rinnai Velare 1500 must be installed as a complete system with its designated, tested, and certified heat pump unit (indoor unit - ESHP60, outdoor unit - HONRTX60). Substituting any other heat pump will void the product warranty.

Warning

Improper installation, adjustment, alteration, service and maintenance can cause property damage, personal injury or loss of life.

For more information about buying, using, and servicing of Rinnai appliances call: 0800 RINNAI (0800 746 624).

Rinnai New Zealand Limited
105 Pavilion Drive, Mangere, Auckland
PO Box 53177, Auckland Airport, Auckland 2150

Phone: (09) 257-3800
Email: info@rinnai.co.nz
Web: rinnai.co.nz
[youtube.com/rinnainz](https://www.youtube.com/rinnainz)
[facebook.com/rinnainz](https://www.facebook.com/rinnainz)

Contents

Safety messages / important information	4
Before you start	5
ES1500HP60 specification summary	6
Refrigerant piping zones.....	7
Zero clearance box installation.....	8
Indoor heat pump installation	10
Outdoor unit positioning.....	14
Outdoor unit installation.....	15
Pipe length and drop height.....	17
Refrigerant piping connection.....	18
Evacuation.....	20
Electrical and gas leaks checks.....	21
Test run.....	22
Error code summary	23
Wiring diagrams.....	25



Use this guide in conjunction with the Velare 1500 Firebox Installation Guide, as it contains important information such as enclosure and framing dimensions.

Safety messages / important information

For safety and warranty, appliances that are damaged MUST NOT be installed or operated under any circumstances.

Electrical warnings



DO NOT modify the electrical wiring of this appliance. If the control power wiring is damaged or deteriorated then it must be replaced by an authorised person. Failure to do so may result in electric shock, fire, serious injury, or product failure.

All wiring must be properly arranged to ensure that the control board cover can close properly. If the control board cover is not closed properly, it can lead to corrosion and cause the connection points on the terminal to heat up, catch fire, or cause electrical shock.

The PCB is designed with a fuse to provide overcurrent protection. The specifications of the fuse are printed on the PCB. For units using R32 refrigerant, only a blast-proof ceramic fuse can be used.

Only connect the unit to an individual branch circuit outlet. Do not connect another appliance to that outlet.

Electrical wires

This is a Class 1 electrical appliance. Make sure the live wire, neutral wire, and earth wire in the power socket are properly connected. Inadequate or incorrect electrical connections may cause fire or electric shock.

The yellow-green wire in the air conditioner is the earthing wire which cannot be used for any other purpose. Improper earthing may cause electric shock. The unit must be earthed in accordance with local regulations.

Every wire must be firmly connected. Loose wiring can cause the terminal to overheat, resulting in a product malfunction and possible fire.

Do not let live wires touch or rest against refrigerant tubing, the compressor, or any moving parts within the unit.

Circuit breaker

The circuit breaker must have the functions of magnetic tripping and heat tripping to prevent short circuiting and/or overload. Use a standard circuit breaker and fuse conforming with the rating of the appliance.

¹ Consult a qualified electrician as it must comply with AS/NZS 5601 and AS/NZS 3000 and other relevant local regulations.

Fixed wiring

If connecting power to fixed wiring¹:

- A surge protector and mains power switch should be installed.
- A switch or circuit breaker that disconnects all poles and has a contact separation of at least $\frac{1}{8}$ " (3 mm) must be incorporated in the fixed wiring.

R32 refrigerant

This appliance uses R32 (difluoromethane) refrigerant, which is a flammable gas, class 2.2 according to AS/NZS 1677 and must be handled by a qualified person with the appropriate refrigerant handling license.

Make sure to check for and rectify any refrigerant leaks after you install or repair the unit.

Certain levels of refrigerant require minimum room sizes. Please ensure that these room sizes are adhered to for standard installations (up to 15 m pipe length). If larger refrigerant charges than standard are used then please consult AS/NZS 60335.2.40 to determine the safe minimum floor area for the installation.

Make sure the area has been made safe by having suitable ventilation and is free from ignition sources before charging or releasing the charge of R32.

Model	6.0 kW
Pre-charge (kg)	1.26
Min. floor area (m²)	14m ²

Never mix refrigerant types.

Note:



Minimum floor area is based on the factory pre-charge in the unit.

Before you start

Unpack the appliance and components, and remove all transit packaging. Check for damage. DO NOT install any damaged items. Check all components have been supplied, refer below.

Read these instructions to get an overview of the steps required before starting the installation. Failure to follow these instructions could cause a malfunction of the appliance. This could result in serious injury and/or property damage.



Indoor unit - in the box

This unit has been modified and has design updates (e.g. lower louvre removed) to ensure compatibility with the Velare Electric Fire.

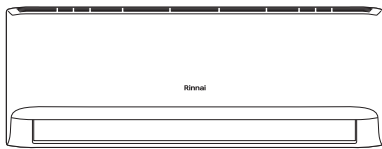

- R32 refrigerant safety manual
- Velare 1500 heat pump system installation guide
- Cold catalyst filter (all black)
- Compound filter (3-in-1)
- Drain plug for outdoor unit
- Velare 1500 remote control
- Pipe connections
- Panel display support
- Control shield panel

Outdoor unit - in the box

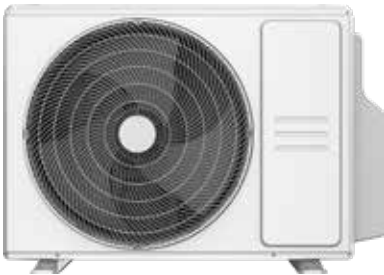

4 x anti vibration rubber pads

Important



The indoor heat pump incorporates design updates, including removal of the lower louvre and relocation of the LED display to a separate enclosure. It will have an additional label (as shown) next to the heat pump data label.

Use these instructions in conjunction with the Velare 1500 - Firebox installation guide.

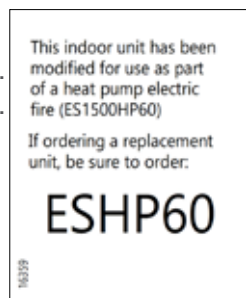

ES1500HP60 specification summary

MODEL	Unit of measure		ES1500HP60
Electric fire			
Carton dimensions and weight		mm	1610W x 620H x 380D
Weight	Firebox weight net / gross	kg	55 / 70
Installation	Suitable area 2.6 m stud height	m ²	22-32
Power and connectivity			
Supply voltage		VAC / Hz	220-240 / 50
Three pin plug type		A	10
Length of power cord		mm	1500
Max. power consumption	Fireplace flame effect	W	70
	Heating and cooling	W	3469
Heat pump system			ESHHP60-HONRTX60
Heating	Rated capacity @ outdoor 7 °C	kW	6.5
	Capacity range	kW	2.4-6.4
	Rated power input	kW	1.7
	Rated current	A	7.43
	ACOP	W/W	3.81
Cooling	Rated capacity @ outdoor 35 °C	kW	6
	Capacity range	kW	2.3-6.2
	Rated power input	kW	1.74
	Rated current	A	7.73
	AEER	W/W	3.45
Energy performance information			
ZERL heating capacity @ outdoor 2 °C		kW	4.96
ZERL energy	Heating (cold zone)	kWh/year	2465
Consumption	Cooling (cold zone)	kWh/year	29
ZERL star rating	Heating (hot / average / cold)		3 / 2.5 / 2
	Cooling (hot / average / cold)		4 / 3.5 / 4
Power and connectivity			
Power supply to outdoor unit		VAC / phase / Hz	220-240 / 1 / 50
Maximum input power		kW	3.4
Power input		W	1.7
Rated current		A	7.43
Indoor unit			ESHHP60
Weight net / gross		kg	11.0 / 14.6
Sound pressure level @ 1 m (hi / silent)		dB(A)	48.5 / 20
Sound power level		dB(A)	59.6
Air flow (turbo / lo)		L/s	264 / 139
Operation	Modes		Heat / cool / dry / fan / auto
	Indoor temp (cooling / heating)	°C	16~32 / 0~30
Outdoor unit			HONRTX60
Weight net / gross		kg	38.6 / 42.1
Sound pressure level @ 1 m		dB(A)	58
Sound power level		dB(A)	67.1
Refrigerant	Type / charged volume		R32 / 1.26 kg
	Pipe size: Liquid gas	mm	Ø6.35 / Ø12.7
	Maximum pipe length	m	30
Operation range outdoor	Heating / cooling	°C	-15~24 / -15~50

Refrigerant piping zones

When choosing a location be aware that there needs to be ample room for a hole for the signal cable and refrigerant piping that connects the indoor and outdoor units. The default position for all piping is to the right side of the indoor unit (while facing the unit), straight out the back. This is preferable, and the safest option, as it ensures no connections inside the house. However the unit can accommodate piping to the left and right.

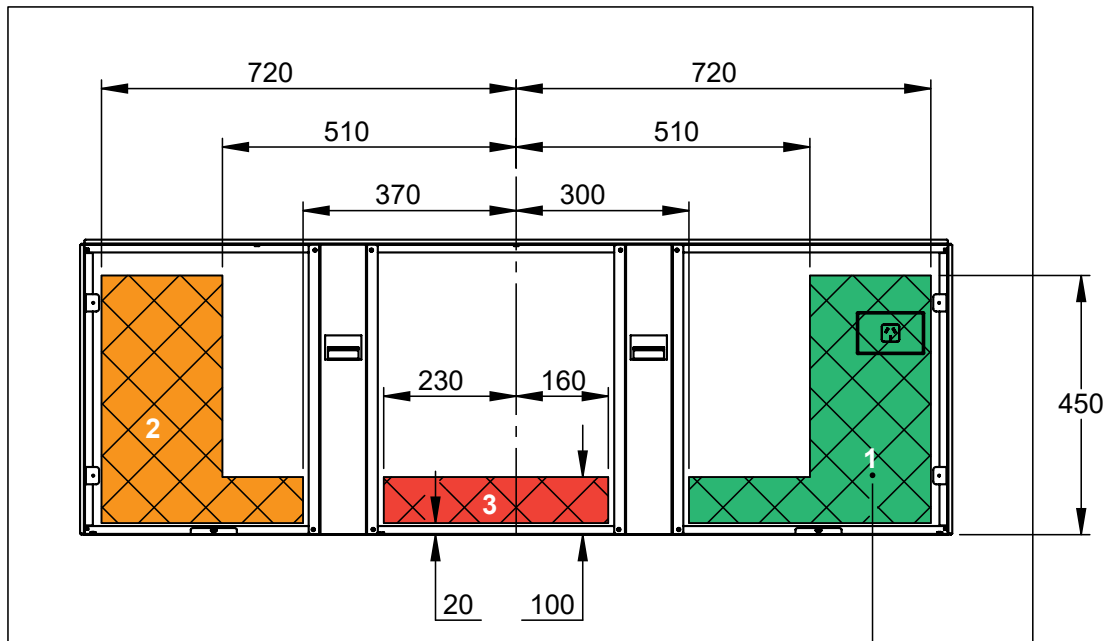

- 1. Preferable location
- 2. Left hand side, second option
- 3. Behind, least favourable

Ø60-75 mm hole for refrigerant and heat pump power. Lower right hand side is preferable for ease of installation.

Zero clearance box installation



The zero clearance box comes flat packed with the electric fire and will require assembly. It is critical it is installed on a flat surface, and that it is square—otherwise the electric fire will not screw into position.



The zero clearance box includes the following:

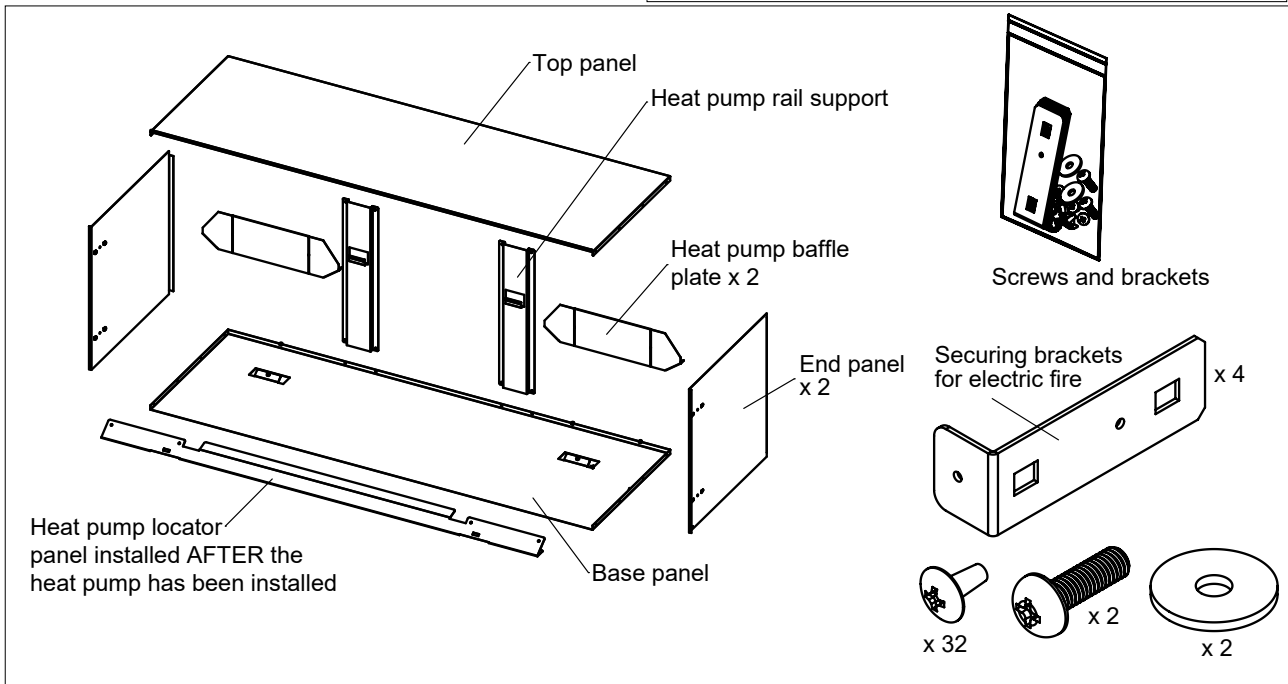

Assemble the zero clearance box **OUTSIDE** of the enclosure¹ and then slide it in. Secure to the framing using the fixing holes as required.

Zero clearance box assembly outside enclosure (on a flat surface, refer images on next page)

1. Place the top panel upside down.
2. Fit the left and right side panels inside of the top panel.
3. Fit the bottom panel.
4. Loosely fit the two heat pump rail supports.
5. Set the zero clearance base upright.
6. Check front faces are square, and check the corner dimensions are equal before fitting into the frame. If square, tighten the heat pump rail supports.
7. Fit the four brackets.



DO NOT install the heat pump locator panel until **AFTER** the heat pump has been installed.

¹ Enclosure/framing dimensions are detailed in the Velare 1500 Firebox installation guide

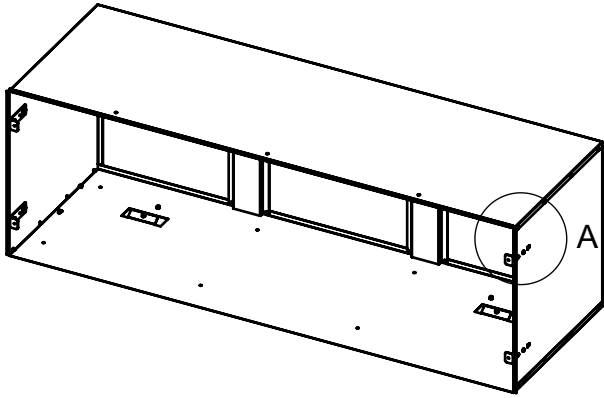

All screws should be fitted from the outside in

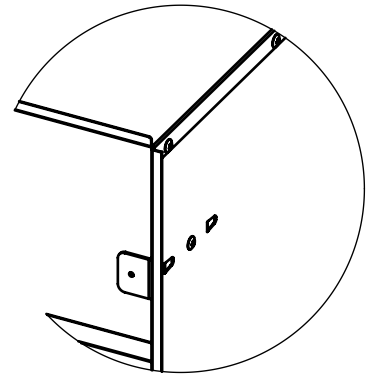

DETAIL A

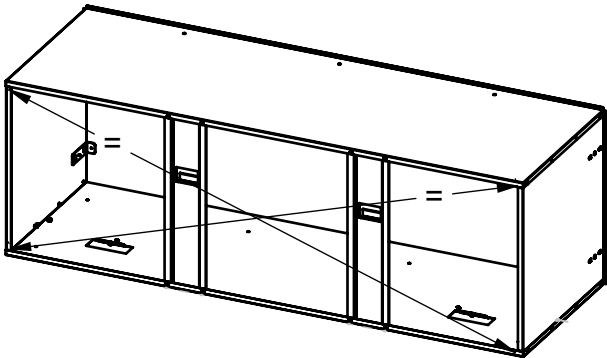

Before tightening the heat pump support rails, check the frame is square



Indoor heat pump installation

Drill hole in wall for connective piping



Running refrigerant piping straight out through the lower right hand side is an easier and safer approach, keeping all connections outside the home.

Determine the location for the hole in the wall. Using a 65 mm or 75 mm core drill, drill a hole in the wall. When drilling make sure to avoid wires, plumbing, and other sensitive components. Make sure that the hole is drilled at a slight downward angle, so that the outdoor end of the hole is lower than the indoor end by approximately 5-7 mm. This will ensure the water drains properly.

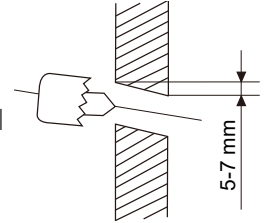

Place the protective wall cuff in the hole. This protects the edges of the hole and will help seal it when the installation is finished.

Install the indoor heat pump into the zero clearance frame



The indoor unit, when installed, must be LEVEL, and have EVEN SPACING (approx. 260~270 mm) either side.

Fit the heat pump to the hooks on the two rail supports and centre between the tabs on the base panel. Connect the refrigerant lines and make sure that the unit is still sitting in the middle of the cavity and can be easily pushed back against the rails at the bottom, and is supported only by the hooks at the top. There will be a gap of approximately 10~15 mm between the base panel and the bottom edge of the heat pump when correctly installed.

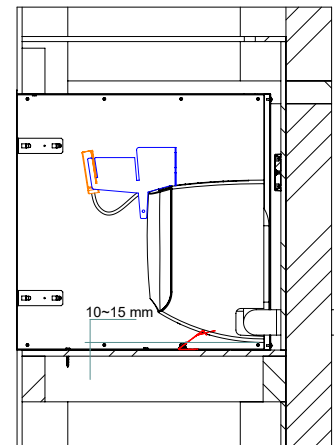

Once correctly seated, fit the prefolded black heat pump locator panel to the base of the zero clearance box using the supplied screws and washers.

Fold the two baffle plates as shown below and fit either side of the heat pump using the key-hole slots over the screws of the heat pump locator panel. The baffle plates hold the heat pump in place and also forms part of the air guide, improving efficiency by preventing air from short-circuiting within the enclosure.

Baffle plate assembly and installation

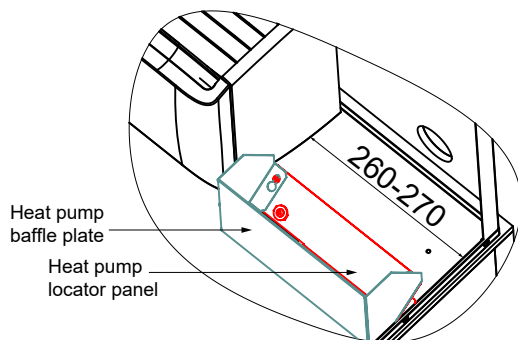
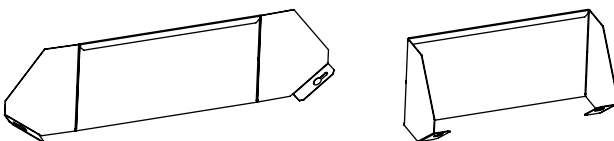



Install the display support and display case

The heat pump control LED display is preinstalled into the display case. This needs to be installed into the display support.

The display support is provided as a flat panel and must be folded into shape. After folding, insert it into the rightmost slots on the top of the heat pump. Once secured, position the display into the front slots of the support, and fit the blanking plate¹ into the slots of the support bracket.

When completed do a quick check of the heat pump operation to ensure the relocated display works, and the heat pump operates as it should before continuing with the electric fire installation.

Control display preinstalled on heat pump



Control display support

Fold the display support bracket as shown above, note location of the left side cutout. If not folded correctly, the heat pump's slight angle will cause the display to be lopsided.

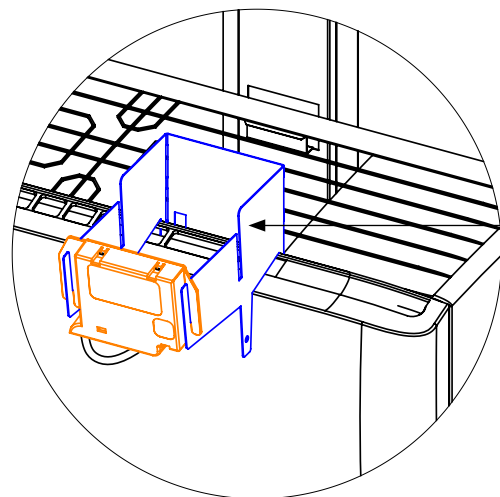
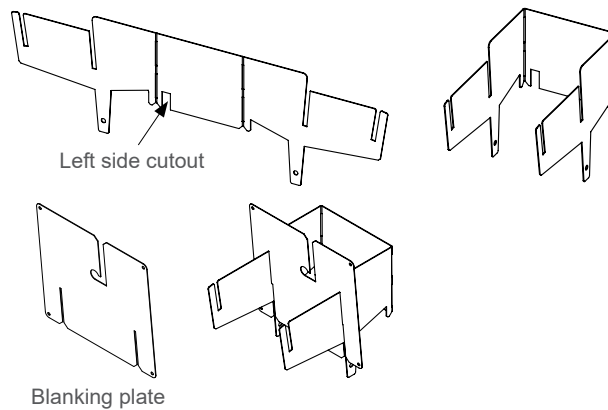

Control display and display support, with blanking plate installed and inserted into the rightmost slots on top of the heat pump

¹ Blanking plate is needed to stop light bleed which can be distracting when the unit is in operation.

Prepare refrigerant piping

The refrigerant piping is inside an insulating sleeve which is attached to the back of the unit. Prepare the piping before passing it through the hole in the wall.

Based on the position of the hole in the wall relative to the mounting plate, choose the side from which the piping will exit the unit. If the hole is behind the unit, keep the knockout panel in place. If the hole is to the side of the indoor unit, remove the plastic knockout panel from that side of the unit. This will create a slot through which your piping can exit. Use needle nose pliers if the plastic panel is too difficult to remove by hand.

Connect the indoor unit's refrigerant piping to the connective piping that will join the indoor and outdoor unit. Be careful not to dent or damage the piping while bending away from the unit. Any dents in the piping will affect the unit's performance.

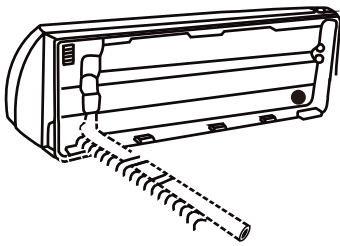

Condensate and drain hose connection

To ensure reliable operation and prevent water damage, the system must have a way to drain condensate. This is the responsibility of the installer. If a condensate pump is installed it should be mounted in an accessible location, installed level, and securely fixed to minimise vibration and noise. All condensate drain lines must be correctly trapped (where required), routed with a continuous fall to the pump, and free from kinks or obstructions. Discharge lines must be appropriately sized, supported, and terminated in a compliant drainage point.

After installation, the pump must be tested with water to confirm correct operation, float switch activation, and shut-off safety function.

By default the drain hose is attached to the left-hand side of the unit (when facing the back of the unit). However, it can also be attached to the right-hand side. To ensure proper drainage attach the drain hose on the same side that your refrigerant piping exits the unit. Attach the drain hose extension (purchased separately) to the end of the drain hose.

Wrap the connection point firmly with Teflon tape to ensure a good seal to prevent leaks. For the portion of drain hose that will remain indoors, wrap it with foam pipe insulation to prevent condensation.

Remove the air filter and pour a small amount of water into the drain pan to make sure that water flows from the unit correctly. To prevent unwanted leaks plug the unused drain hole with the rubber plug provided.

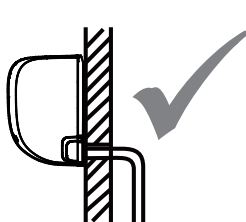

CORRECT
No kinks or dents in the drain hose ensures proper drainage.

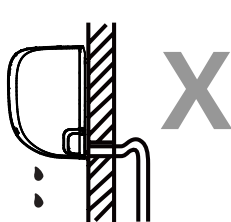

INCORRECT
Kinks in the drain hose will create water traps.

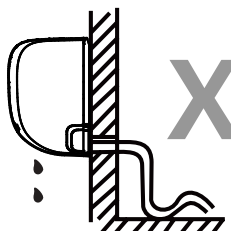

INCORRECT
Kinks in the drain hose will create water traps.

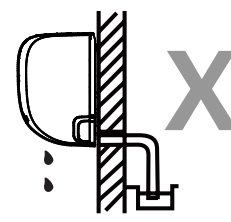

INCORRECT
Do not place the end in water or other containers that collect water. This will prevent proper drainage.

Connect signal and power cables



Before performing any electrical or wiring work, turn off the mains power to the system. All wiring must be performed in accordance with the wiring diagram located on the back of the indoor unit's front panel.

The signal cable enables communication between the indoor and outdoor units. You must choose the right cable size before preparing it for connection. The size of the power supply cable, signal cable, fuse, and switch is determined by the maximum current of the unit. The maximum current is indicated on the data plate located on the side panel of the unit.

1. Open front panel of the indoor unit.
2. Using a screwdriver, open the wire box cover on the right side of the unit, this will reveal the terminal block.
3. Unscrew the cable clamp below the terminal block and place it to the side.
4. Facing the back of the unit, remove the plastic panel on the bottom left-hand side.
5. Feed the signal wire through this slot, from the back of the unit to the front.
6. Facing the front of the unit, connect the wires according to the wiring diagram, connect the u-lug and firmly screw each wire to its corresponding terminal.
7. Make sure every connection is secure, use the cable clamp to fasten the signal cable to the unit. Screw the cable clamp down tightly.
8. Replace the wire cover on the front of the unit, and the plastic panel on the back.

Wrap piping and cables

Before passing the piping, drain hose, and the signal cable through the wall bundle them together to save space, protect and insulate them.

Bundle the drain hose, refrigerant pipes, and signal cable as shown. Make sure the drain hose is at the bottom of the bundle. Putting the drain hose at the top can cause the drain pan to overflow, which can lead to fire or water damage.

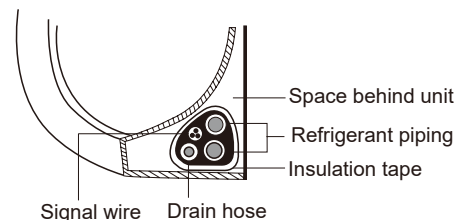

While bundling, DO NOT intertwine or cross the signal cable with any other wiring.

Using adhesive vinyl tape, attach the drain hose to the underside of the refrigerant pipes. Using insulation tape, wrap the signal wire, refrigerant pipes, and drain hose tightly together. When wrapping the bundle keep the ends of the piping unwrapped so they can be tested for leaks at the end of the installation process.

Perform leak test

1. Connect drain hose and refrigerant piping, refer previous pages.
2. Keep the pipe connection points exposed to perform the leak test. After the leak test wrap the connection points with insulation tape.

Outdoor unit positioning

Clearances

The outdoor unit must be installed in accordance with the clearances outlined below. Note maintenance access, there must be sufficient room for installation and maintenance.

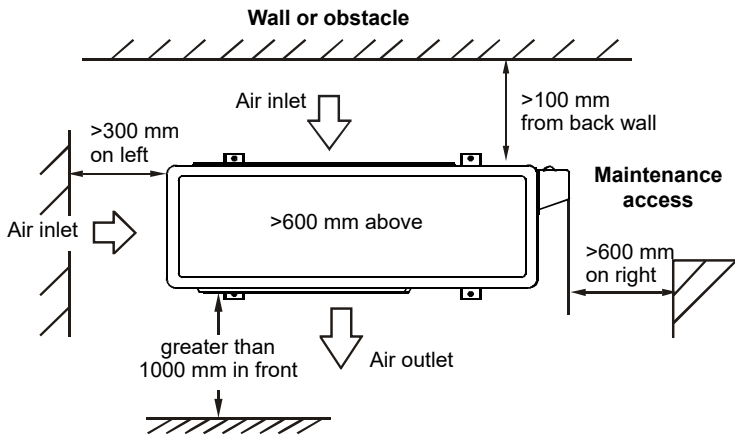

Ensure the following:

- Good air circulation and ventilation
- Noise from the unit will not disturb others
- Firm and solid—location will not vibrate
- Protected from prolonged periods of direct sunlight or rain
- Where snow is anticipated, raise the unit above the base pad to prevent ice buildup and cold damage. Mount the unit high enough to be above the average accumulated area snowfall.

DO NOT install:

- Near any source of combustible gas
- In locations exposed to excessive dust
- Near an obstacle that will block the air inlets and outlets
- Near animals or plants that will be harmed by hot air discharge
- Where it will be exposed to sea wind (salt spray) as this will reduce durability

Special considerations for extreme weather

If the unit is exposed to strong prevailing winds install the unit so that the air outlet fan is at a 90 degree angle to the direction of the wind. If needed, build a barrier in front of the unit to protect it from extremely strong winds.

If the unit is exposed to heavy rain or snow, build a shelter above the unit. Be careful not to obstruct air flow around the unit.

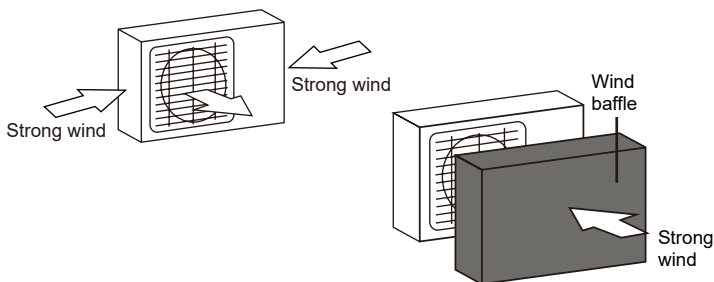

Wall or roof mounted installations

If the outdoor unit is installed on roof structures or external walls, this may result in excessive noise and vibration. It may also be classed as a non-serviceable installation and may void warranty.

Outdoor unit installation

1. Select installation location

Refer notes and clearances diagram on previous page.

2. Install drain joint

Before bolting the outdoor unit in place, install the drain joint at the bottom of the unit so condensate can be properly drained away so as not to cause property damage.



3. Anchor outdoor unit

The outdoor unit can be anchored to the ground or to a wall bracket with M10 bolts. Prepare the installation base of the unit according to the dimensions of the model being installed.

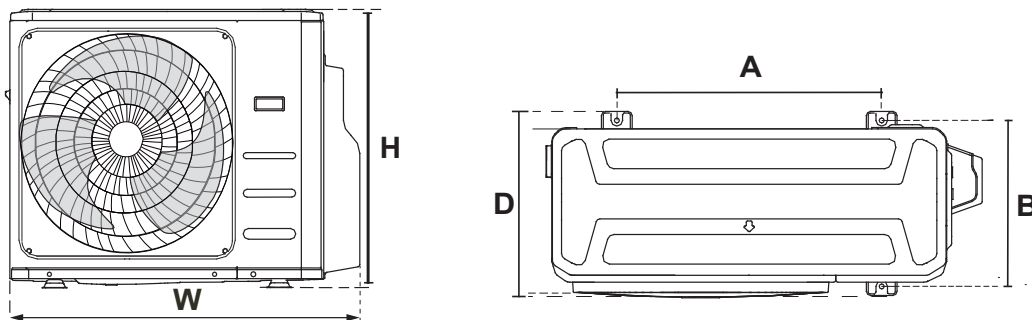

Model	Outdoor unit dimensions			Mounting dimensions	
	Width - W	Height - H	Depth - D	Distance A	Distance B
HONRTX60	890 mm	673 mm	342 mm	663 mm	354 mm

If the unit is installed on the ground or on a mounting platform do the following:

- Mark the positions for the four expansion bolts based on the model
- Pre-drill holes for the expansion bolts.
- Place a nut of the end of each expansion bolt.
- Hammer the expansion bolts into the pre-drilled holes.
- Remove the nuts from the expansion bolts, and place the outdoor unit on the bolts.
- Put a washer on each expansion bolt, then replace the nuts.
- Using a wrench tighten each nut until snug.

If installing the unit on a wall mounted bracket do the following:

- Mark the position of the bracket holes based on the dimensions of the model.
- Pre-drill the holes for the expansion bolts.
- Place a washer and nut on the end of each expansion bolt.
- Thread expansion bolts through the holes in the mounting brackets, put the mounting brackets in position, and hammer expansion bolts into the wall.
- Check the mounting brackets are level.
- Carefully lift the unit and place the mounting feet on the brackets.
- Bolt the unit firmly to the brackets.
- If applicable, install the unit with rubber gaskets to reduce vibration and noise.

4. Connect signal and power cables



Before performing any electrical or wiring work, turn off the mains power to the system. All wiring must be performed in accordance with the wiring diagram located on the inside of the wiring cover.

The signal cable enables communication between the indoor and outdoor units. You must choose the right cable size before preparing it for connection. The size of the power supply cable, signal cable, fuse, and switch is determined by the maximum current of the unit. The maximum current is indicated on the data plate located on the side panel of the unit.

The outside unit's terminal block is protected by an electrical wiring cover on the side of the unit.

1. Prepare the cable for connection. Using wire strippers, strip the rubber jacket from both ends of the cable to reveal approximately 40 mm of the wires inside. Strip the insulation from the ends of the wires. Using a crimper, crimp u-lugs on the ends of the wires. While crimping make sure to clearly distinguish the live wire from the other wires.
2. To access the electrical control box remove the screws from the side cover.
3. Connect the wires according to the wiring diagram, and firmly screw the u-lug of each wire to its corresponding terminal.
4. After checking to make sure every connection is secure, loop the wires around to prevent rain water from entering into the terminal.
5. Using the cable clamp, fasten the cable to the unit. Screw the cable clamp down tightly.
6. Insulate unused wires with PVC electrical tape. Arrange them so that they do not touch any electrical or metal parts.
7. Replace the wire cover on the side of the unit and screw it in place.

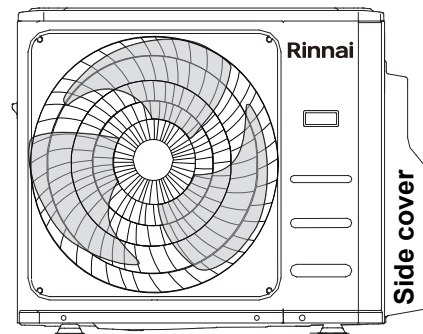

Pipe length and drop height

The length and elevation of the connection pipe is shown in the table below. If the pipe length exceeds charged pipe length, additional refrigerant should be charged to ensure nominal cooling/heating capacity.

Capacity	Pre-charge length	Max. pipe length	Max. elevation	Additional refrigerant
6.0 kW	15 m	30 m	20 m	12 g/m

If oil flows back into the outdoor unit's compressor, this might cause liquid compression or deterioration of oil return. Oil traps in the rising gas pipe can prevent this.

If the outdoor unit is installed higher than the indoor unit, oil should return to the compressor along with the suction of refrigerant to keep the compressor lubricated. If the suction flow velocity drops below 7.62 m/s oil won't return to the compressor—an oil trap should be installed every 6m of vertical distance.

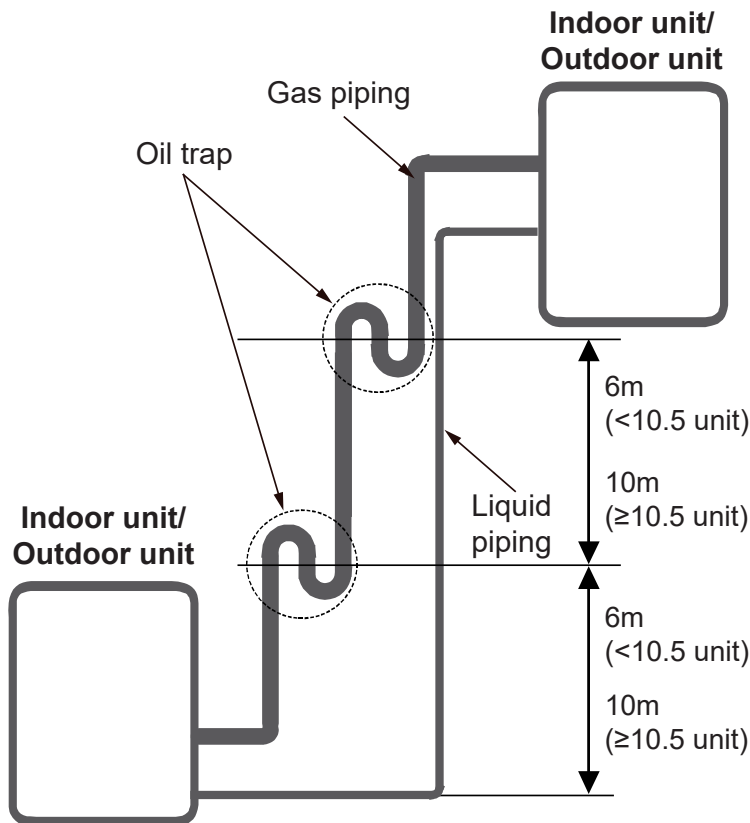

Refrigerant piping connection



When connecting refrigerant piping do not let substances or other gases other than the specified refrigerant enter the unit. The presence of other gases or substances will lower the unit's capacity, and can cause abnormally high pressure in the refrigeration cycle. This can cause explosion and injury.

The length of refrigerant piping will affect the performance and energy efficiency of the unit. Nominal efficiency is tested on units with a pipe length of 5 m—a minimum pipe run of 3 m is required to minimise vibration and excessive noise.

1. Cut pipes

Be careful not to damage, dent, or deform the pipe while cutting. This will drastically reduce the heating efficiency of the unit. When preparing refrigerant pipes, take extra care to cut and flare them properly. This will ensure efficient operation and minimise the need for future maintenance and repair.

1. Measure the distance between the indoor and outdoor units.
2. Using a pipe cutter, cut the pipe a little longer than the measured distance.
3. Make sure that the pipe is cut at a perfect 90° angle.

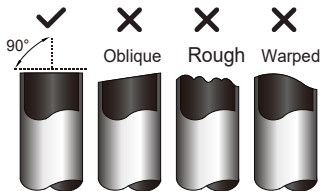

2. Remove burrs

Burrs can affect the airtight seal of the refrigerant pipe connection, they must be completely removed.

1. Hold the pipe at a downward angle to prevent burrs from falling into the pipe.
2. Using a deburring tool, remove all burrs from the cut section of the pipe.

3. Flare pipe ends

Proper flaring is essential to achieve an airtight seal.

1. After removing burrs from the cut pipe, seal the ends with PVC tape to prevent foreign materials from entering the pipe.
2. Sheath the pipe with insulating material.
3. Place flare nuts on both ends of the pipe. Make sure they are facing in the right direction. You can't put them on or change their direction after flaring.
4. Remove PVC tape from the ends of the pipe when ready to perform flaring work.
5. Clamp flare form on the end of the pipe. The end of the pipe must extend beyond the edge of the flare form in accordance with the dimensions below.

Outer diam. of pipe (mm)	A (mm)	
	Minimum	Maximum
Ø 6.35 (Ø 0.25 ")	0.7 (0.0275 ")	1.3 (0.05 ")
Ø 12.7 (Ø 0.5 ")	1.0 (0.04 ")	1.8 (0.07 ")

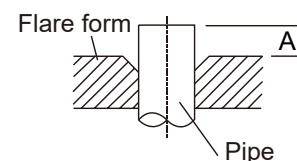

3. Flare pipe ends continued

Place flaring tool onto the form. Turn the handle of the flaring tool clockwise until the pipe is fully flared. Remove the flaring tool and flare form, then inspect the end of the pipe for cracks and even flaring.

4. Connect pipes

When connecting refrigerant pipes be careful not to use excessive torque or to deform the piping in any way. You should first connect the low-pressure pipe, then the high pressure pipe. When bending connective refrigerant piping, the minimum bend radius is 10 cm.

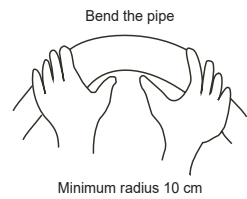

Connecting pipe to indoor unit

1. Align the center of the two pipes being connected.

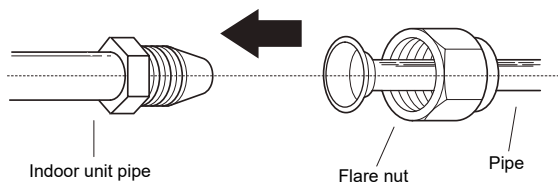

2. Tighten the flare nut as tightly as possible by hand.

3. Using a spanner, grip the nut on the unit pipe.

4. While firmly gripping the nut on the unit pipe, use a torque wrench to tighten the flare nut according to the torque values in the table below. Loosen the flare nut slightly then tighten again. DO NOT use excessive torque, excessive force can break the nut or damage the refrigerant piping.

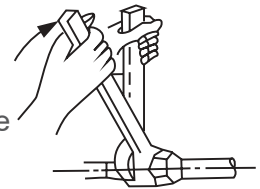

Outer diam. of pipe (mm)	Tightening torque (N•m)	Flare dimension B (mm)
Ø 6.35 (Ø 0.25 ")	18~20 (180-200 kgf.cm)	8.4~8.7 (0.33~0.34 ")
Ø 12.7 (Ø 0.5 ")	49~59 (490-590 kgf.cm)	16.2~16.5 (0.64~0.65 ")

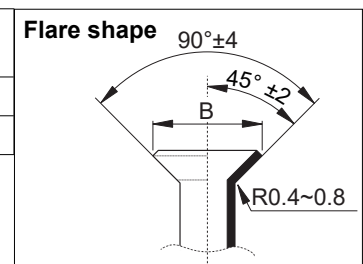

Connecting pipe to outdoor unit

1. Unscrew the cover from the packed valve on the side of the outdoor unit.

2. Remove protective caps from ends of valves.

3. Align flared pipe end with each valve, and tighten the flare nut as tightly as possible by hand.

4. Using a spanner, grip the body of the valve. Do not grip the nut that seals the service valve. Over tightening of the flare nut can snap off other parts of the valve.

5. While firmly gripping the body of the valve use a torque wrench to tighten the flare nut according to the torque values above.

6. Loosen the flare nut slightly then tighten again.

7. Repeat steps 3-6 for the remaining pipe.

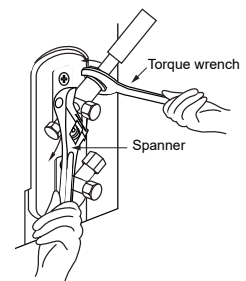

Evacuation

Air and foreign matter in the refrigerant circuit can cause abnormal rises in pressure, which can damage the unit, reduce its efficiency, and cause injury. Use a vacuum pump and manifold gauge to evacuate the refrigerant circuit, removing any residual gas and moisture from the system. Evacuation should be performed upon initial installation and when the unit is relocated.

Before performing evacuation make sure the connecting pipes between the units, and all the wiring, is connected properly.

1. Connect the charge hose of the manifold gauge to the service port on the outdoor unit's low pressure valve.
2. Connect another charge hose from the manifold gauge to the vacuum pump.
3. Open the low pressure side of the manifold gauge. Keep the high pressure side closed.
4. Turn on the vacuum pump to evacuate the system.
5. Run the vacuum for at least 15 minutes, or until the compound meter reads -76 cmHg (-10⁵ Pa).
6. Close the low pressure side of the manifold gauge, and turn off the vacuum pump.
7. Wait five minutes, then check that there has been no change in system pressure. If there is a change in system pressure, refer to gas leak checks on next page. If there is no change, unscrew the cap from the high pressure valve and using a hexagonal wrench open the valve by a quarter turn (clockwise). Listen for gas exiting the system, then close the valve after five seconds.
8. Watch the pressure gauge for one minute and make sure that there is no change in pressure. The pressure gauge should read slightly higher than atmospheric pressure.
9. Remove the charge hose from the service port. Using a hexagonal wrench, fully open both the high pressure and low pressure valves. Tighten valve caps on all three valves (service port, high pressure, low pressure) by hand. You may tighten it further using a torque wrench if needed.

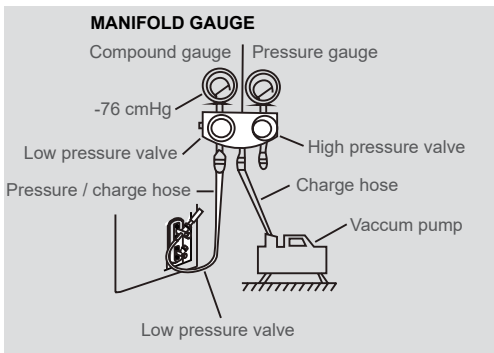

Adding refrigerant

Some systems require additional charging depending on pipe lengths. The standard pipe length varies according to local regulations. The refrigerant should be charged from the service port on the outdoor unit's low pressure. The additional refrigerant to be charged can be calculated using the following formula.

Connective pipe length	Air purifying method	Additional refrigerant
> Std. pipe length (m)	Vacuum pump	Liquid side Ø 6.35 (ø 0.25") (pipe length-standard length) x 12g/m
		Liquid side Ø 9.52 (ø 0.375") (pipe length-standard length) x 24g/m

Open valve stems gently



When opening valve stems, turn the hexagonal wrench until it hits against the stopper. Do not try to force the valve to open further.

Electrical and gas leak checks

Confirm the unit's electrical system is safe and operating properly. Check all flare nut connections and confirm the system is not leaking. Confirm gas and liquid (high and low pressure) valves are fully open.

Electrical safety checks

After installation confirm that all electrical wiring is installed in accordance with the wiring diagrams on the appliance and with local regulations.

Before test run - check grounding work

Measure grounding resistance by visual detection and with a grounding resistance tester. Grounding resistance must be less than 0.1 Ω .

During test run- check for electrical leakage

During the test run, use a multimeter to perform a comprehensive electrical leakage test. If electrical leakage is detected, turn off the unit immediately and call a licensed electrician to find and resolve the cause of the leakage.

Gas leak checks

There are two different methods to check for gas:

Soap and water

Using a soft brush, apply soapy water or liquid detergent to all pipe connection points on the indoor, and outdoor unit. The presence of bubbles indicates a leak.

Leak detector method

If using a leak detector, refer to the device's instructions for correct usage.

After confirming that all the pipe connection points do not leak, replace the valve cover on the outside unit.

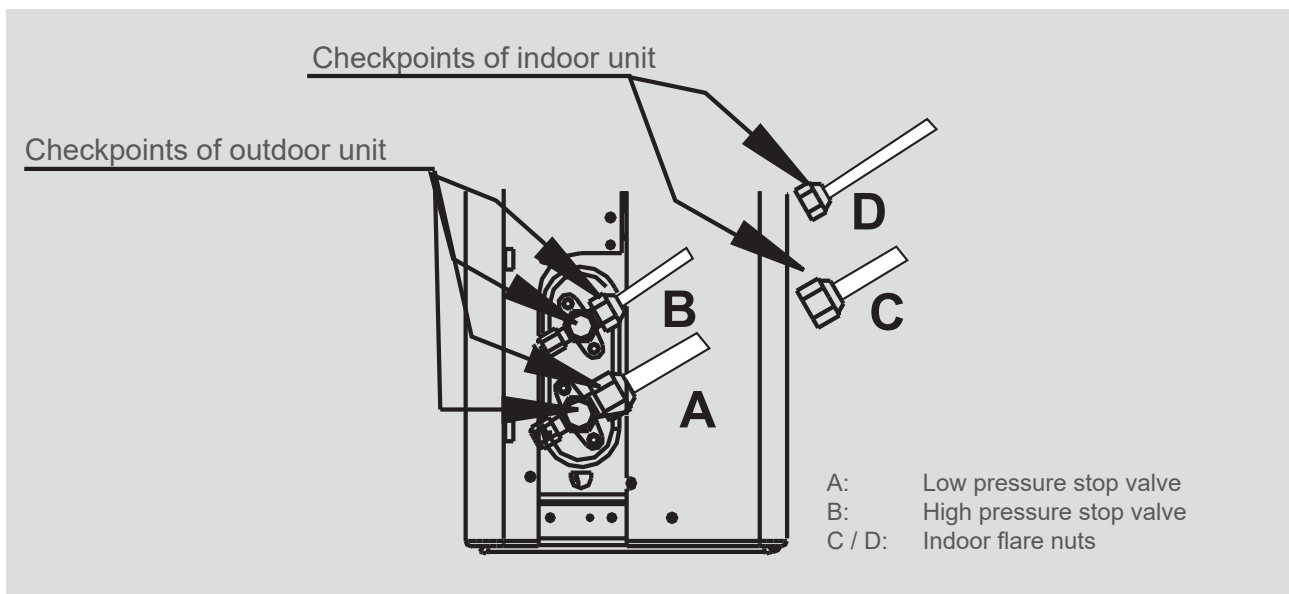

Test run



Perform the test run for at least thirty minutes.

1. Connect power to the unit and press the ON/OFF button on the remote to turn it on.
2. Press the MODE button to scroll through the following functions:
 - COOL select the lowest temperature
 - HEAT select the highest temperature

Let each function run for five minutes and perform the following checks:

- No electrical leakage
- Unit is properly grounded
- All electrical terminals properly covered
- Indoor and outdoor units installed correctly
- All pipe connections do not leak
- Water drains properly from the drain hose
- All piping is properly insulated
- COOL function performs correctly
- HEAT function performs correctly
- Indoor unit remote operates correctly

During operation, the pressure of the refrigerant circuit will increase. This may reveal leaks that were not present during your initial leak check. Take time during the test to double-check that all refrigerant pipe connection points do not have leaks.

During installation and test run you may get an error code, refer to the error code summary to help diagnose the fault.

3. After the test run is successfully completed and all checks PASS, do the following:
 - Using the remote, return the unit to a normal operating temperature
 - Using insulation tape, wrap the indoor refrigerant pipe connections left uncovered

Ambient temperature below 17 °C



When the ambient temperature is below 17 °C the COOL function won't work. In this instance you can use the manual control button to test the COOL function. Lift the front panel of the indoor unit and raise it until it clicks. The manual control button is on the right hand side of the unit. Press it two times to select the COOL function. Perform test run as normal.

Error code summary

Indoor and outdoor combined

Error code	Error description
EH 00 / EH 0R	Indoor unit EEPROM ¹ parameter error
EL 01	Indoor / outdoor communication error
EH 02	Zero crossing signal detection error
EH 30	Over low voltage protection of indoor external fan
EH 31	Over voltage protection of indoor external fan
EH 03	Indoor fan speed operating outside the normal range
EC 51	Outdoor unit EEPROM parameter error
EC 52	Condenser coil temperature sensor T3 is in open circuit or has short circuited
EC 53	Outdoor room temperature sensor T4 is in an open circuit or has short circuited
EC 54	Compressor discharge temperature sensor TP is in an open circuit or has short circuited
EC 56	Evaporator coil outlet temperature sensor T2B is in an open circuit or has short circuited
EH 60	Indoor room temperature sensor T1 is in an open circuit or has short circuited
EH 61	Evaporator coil temperature sensor T2 is in an open circuit or has short circuited
EC 07	The outdoor fan speed is operating outside the normal range
EH 0b	Indoor PCB / display board communication error
EL 0C	Refrigerant leak detected. The unit will stop operating to protect the compressor.
PC 00	IPM malfunction or IGBT over-strong current protection
PC 10	Over low voltage protection
PC 11	Over voltage protection
PC 12	DC voltage protection
PC 02	Compressor top high temperature protection (OLP)
PC 03	Pressure protection
PC 40	Communication error between outdoor main chip and compressor driven chip
PC 41	Current input detection protection
PC 42	Compressor start error
PC 43	Lack of phase (3 phase) protection
PC 44	No speed protection
PC 45	341 PWM error
PC 46	Compressor speed malfunction
PC 49	Compressor over current protection
--	Indoor unit mode conflict (match with multi outdoor unit)
PC 0R	Condenser high temperature protection
FH 0C	Humidity sensor is in open circuit or has short circuited
PC 06	Compressor discharge temperature protection
PC 08	Outdoor current protection
PH 09	Anti-cold air in heating mode
PC 0F	PFC module malfunction
PC 30	High pressure protection

Error code	Error description
PC 31	Low pressure protection
PC 0L	Outdoor ambient temperature too low
PH 90	Evaporator coil temperature over high protection
PH 91	Evaporator coil temperature over low protection
LC 01	Frequency limit caused by T3
LC 02	Frequency limit caused by TP
LC 03	Frequency limit caused by over current
LC 05	Frequency limit caused by voltage
LC 06	Frequency limit caused by PFC
LH 00	Frequency limit caused by T2
LH 07	Frequency limit caused by remote controller
NA	No malfunction or protection

Please note



EEPROM: Electrically Erasable Programmable Read-Only Memory. A small memory chip used to store important data that must be retained even when the unit is off. In the case of HVAC units it usually relates to a control board error.

T1: Indoor air temperature sensor (room temp.) - replacement part 'Room temperature sensor'

T2: Indoor coil (evaporator) temp. sensor - replacement part 'Pipe temperature sensor'

T3: Outdoor ambient temp. sensor (outdoor air) - replacement part 'Combination sensor'

T4: Sometimes used for the outdoor coil (condenser) temp - replacement part 'Combination sensor'

IPM (Intelligent Power Module): For NZ models, the IPM is not available as a replacement part. If an IPM fault occurs, the indoor or outdoor PCB is typically replaced instead.

PWM: Pulse Width Modulation. The control board is not receiving a proper PWM signal to control the compressor or fan.

Wiring diagram

Indoor wiring diagram: 6 kW model

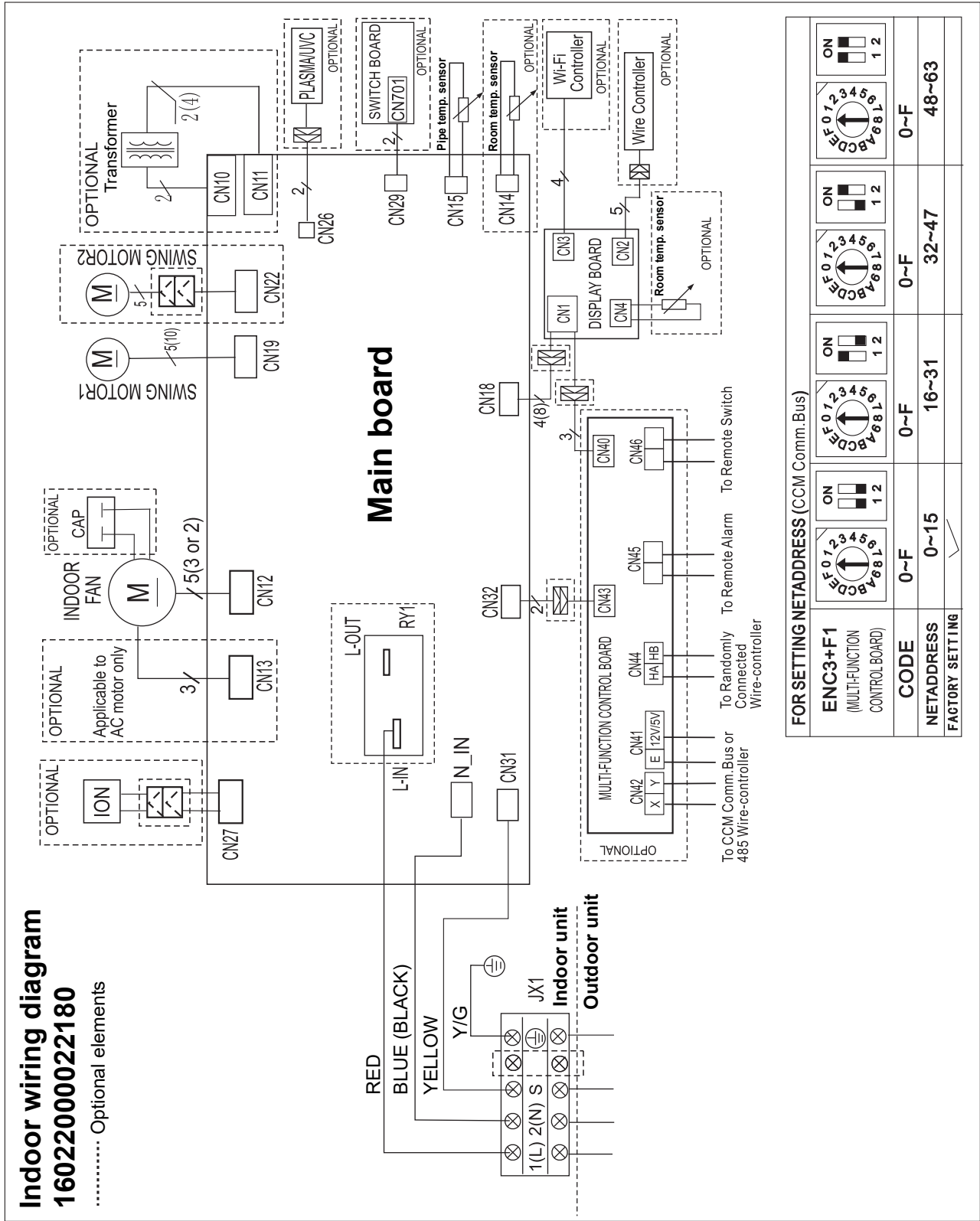

Wiring diagram

Outdoor wiring diagram

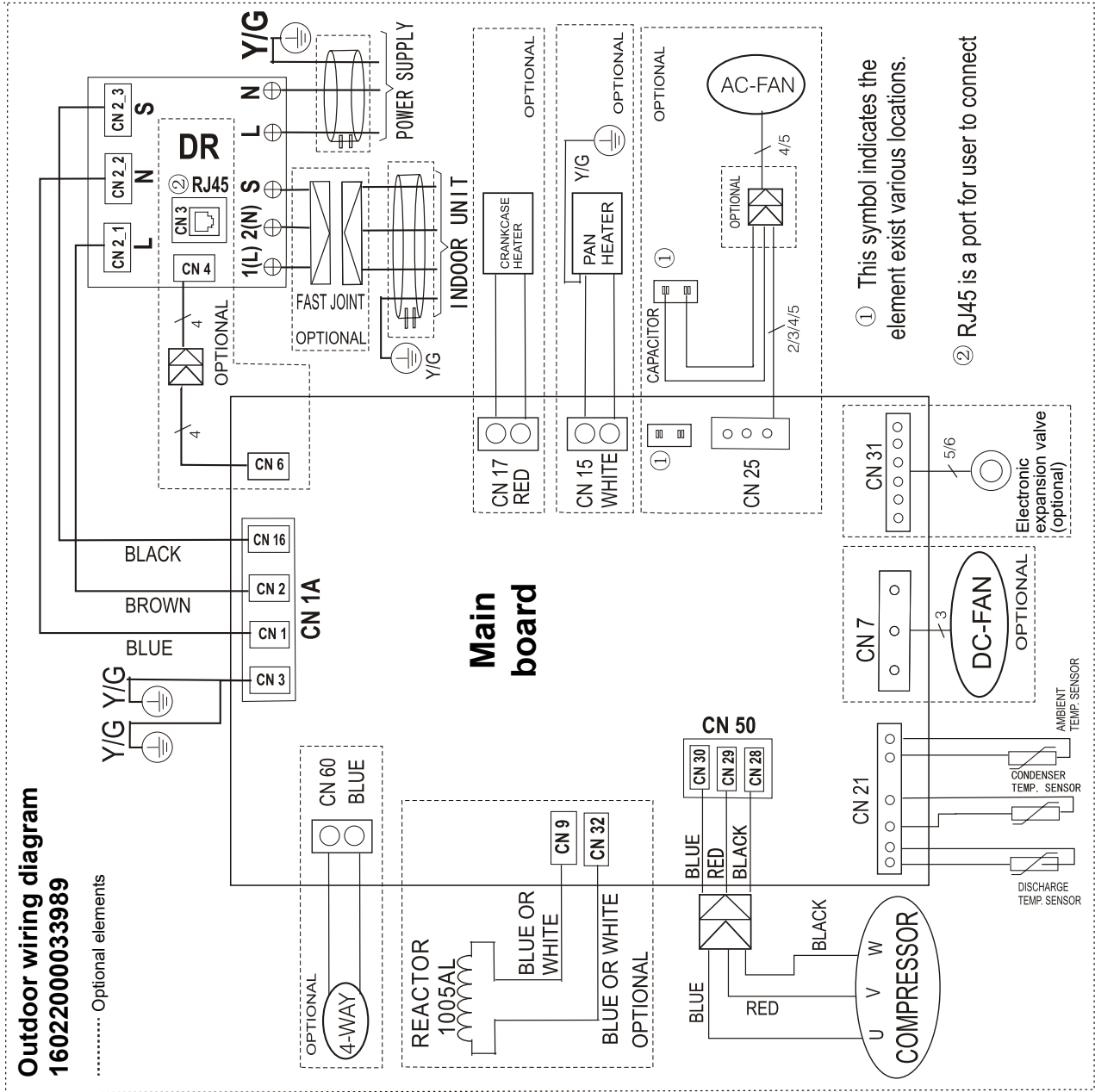

Rinnai.co.nz

Tel: 0800 746 624
<http://www.youtube.com/rinnainz>
<http://facebook.com/rinnainz>

Velare 1500 Heat Pump installation guide
16360-B