

MODEL:

ES1500HPFB



Velare 1500 - Hybrid Electric Fire: Firebox Installation guide

Rinnai

Important

This appliance must be installed in accordance with:

- Manufacturer's installation instructions
- Current AS/NZS 3000, AS/NZS 5141, AS/NZS 5149, AS/NZS 1677, AS/NZS 60335.2.40, and G12/AS1

Appliance must be installed, commissioned and serviced by an authorised person.

The Rinnai Velare 1500 must be installed as a complete system with its designated, tested, and certified heat pump unit (indoor unit - ESHP60, outdoor unit - HONRTX60). Substituting any other heat pump will void the product warranty.

Warning

Improper installation, adjustment, alteration, service and maintenance can cause property damage, personal injury or loss of life.

For more information about buying, using, and servicing of Rinnai appliances call: 0800 RINNAI (0800 746 624).

Rinnai New Zealand Limited
105 Pavilion Drive, Mangere, Auckland
PO Box 53177, Auckland Airport, Auckland 2150

Phone: (09) 257-3800
Email: info@rinnai.co.nz
Web: rinnai.co.nz
[youtube.com/rinnainz](https://www.youtube.com/rinnainz)
[facebook.com/rinnainz](https://www.facebook.com/rinnainz)

Contents

Before starting	4
Specification summary	5
Schematic.....	6
Appliance location	7
Clearances	8
Installation overview	9
Before starting	10
Enclosure and framing details	11
Refrigerant piping zones	12
Electric fire power supply.....	13
Installation	14
Media setup.....	17
Front glass installations	18
Check appliance operation.....	18
Installation checklist and customer handover.....	18
Wiring layout.....	19



Rinnai appliances require regular maintenance and servicing. For reliable operation, the heat pump component should be serviced annually. The electric fire requires minimal maintenance; however it needs to be removed to access the heat pump and can be checked at the same time. Regular servicing will help extend the life of the system.

A service visit generally includes cleaning the glass, filters, coils, and fans; removing dust or debris from internal and external components; checking drainage, sensors, controls, and electrical connections; and inspecting refrigerant lines and system performance. Technicians also review the overall condition of the indoor and outdoor units to identify any issues early.

Specification summary



Blending stunning flame visuals with advanced heat pump innovation, the Rinnai Velare delivers both **heating and cooling** from a single, beautifully designed appliance.

Enjoy year-round comfort with instant warmth in winter and efficient cooling in summer—all behind a hyper-realistic flame and fuel bed display. Controlled using a simple infra-red remote.



R32 refrigerant models **MUST BE** installed, operated and stored in a room with a floor area larger than 14m².

VELARE ELECTRIC FIRE				
Model	ES1500HP60			
Suitable area	22-32 m ² (based on a 2.6 m stud height)			
Suitability	Suitable for indoor domestic applications only. Do not install near a wet area such as a bath, shower, or swimming pool.			
Data plate position	Top panel right hand side—will have the serial number of the appliance.			
Electrical supply	Power supply is 230 V, control PCB 12 V, motor 12 V DC			
3-pin plug type	10 A with a power lead of 1500 mm			
Power consumption		Electric fire	HP	Total system
	Max. power consumption	70 W		3469 W
	Standby current consumption	0.06 A		
	Standby power consumption	4 W		
	Power input	70 W	1.7 W	1170 W
Rated current	0.32 A	7.43 A	7.75 A	
Carton dimensions	W - 1610 mm, D - 380 mm, H - 620 mm			
Weight	Gross - 70 kg			
	Net - 55 kg			

Firebox data plate example

ES1500HP60	
Manufacture name	Rinnai
Model number	ES1500HPFB
Rated Voltage	230-240V~
Rated frequency	50 Hz
Rated Power	75 Watts Max
Date of Manufacture	29/01/2026
Serial Number	10002
MANUFACTURED BY RINNAI NZ LTD, AUCKLAND NZ	
P/N 16355	
ES1500HP60	

Dimensions (mm)

Unit dimensions including trim

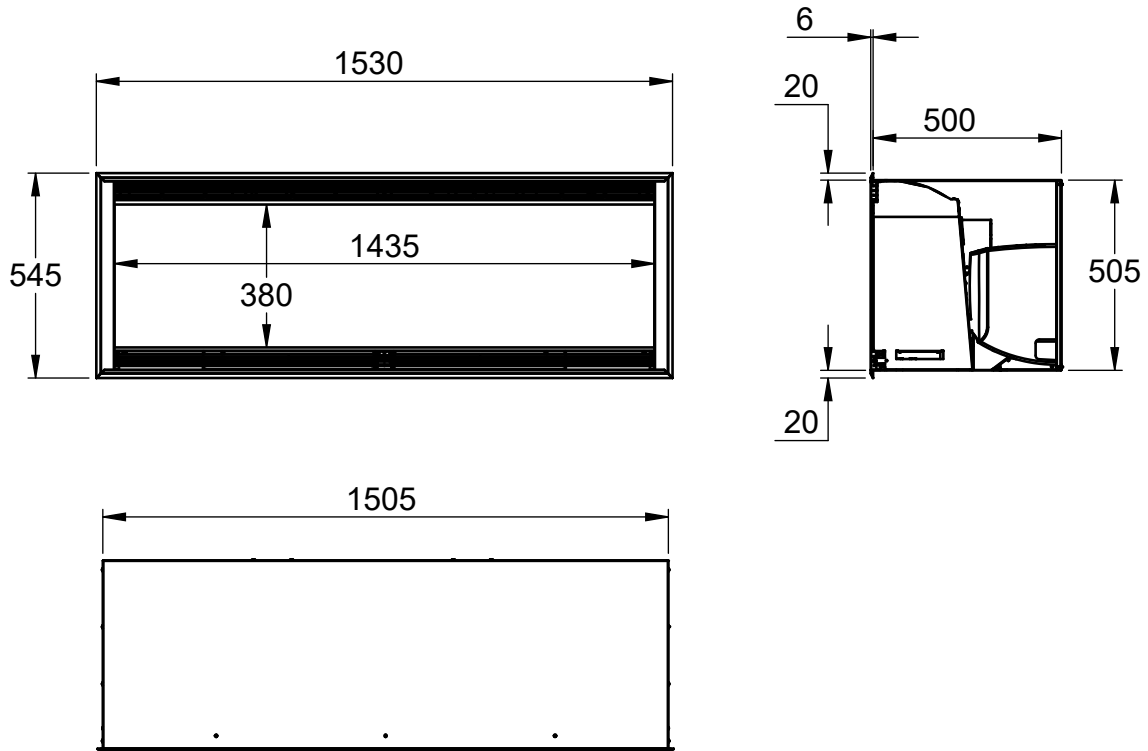

Electric fire trim

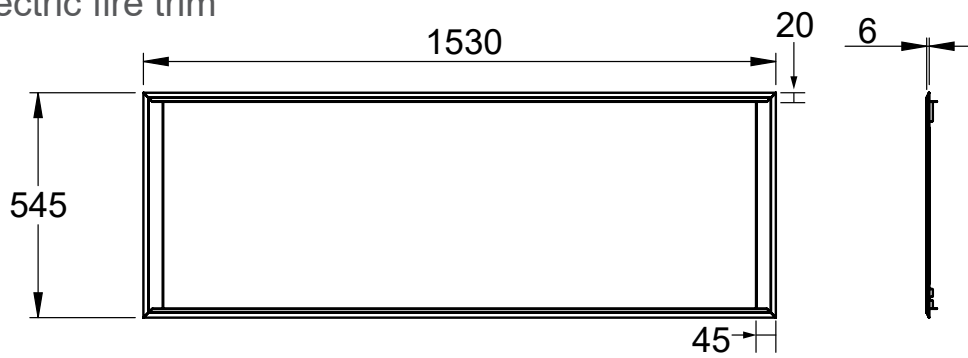

Schematic

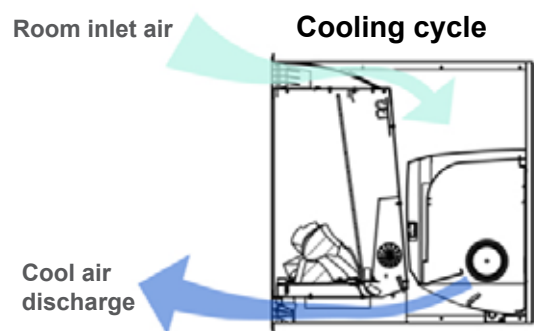
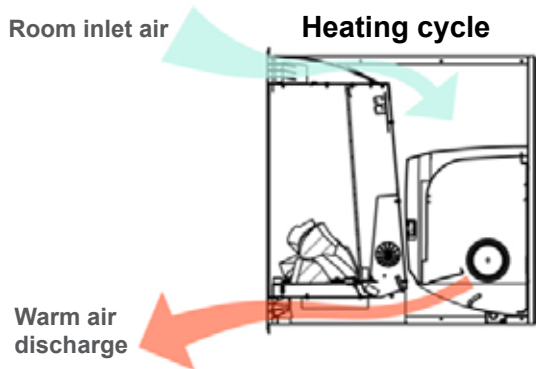
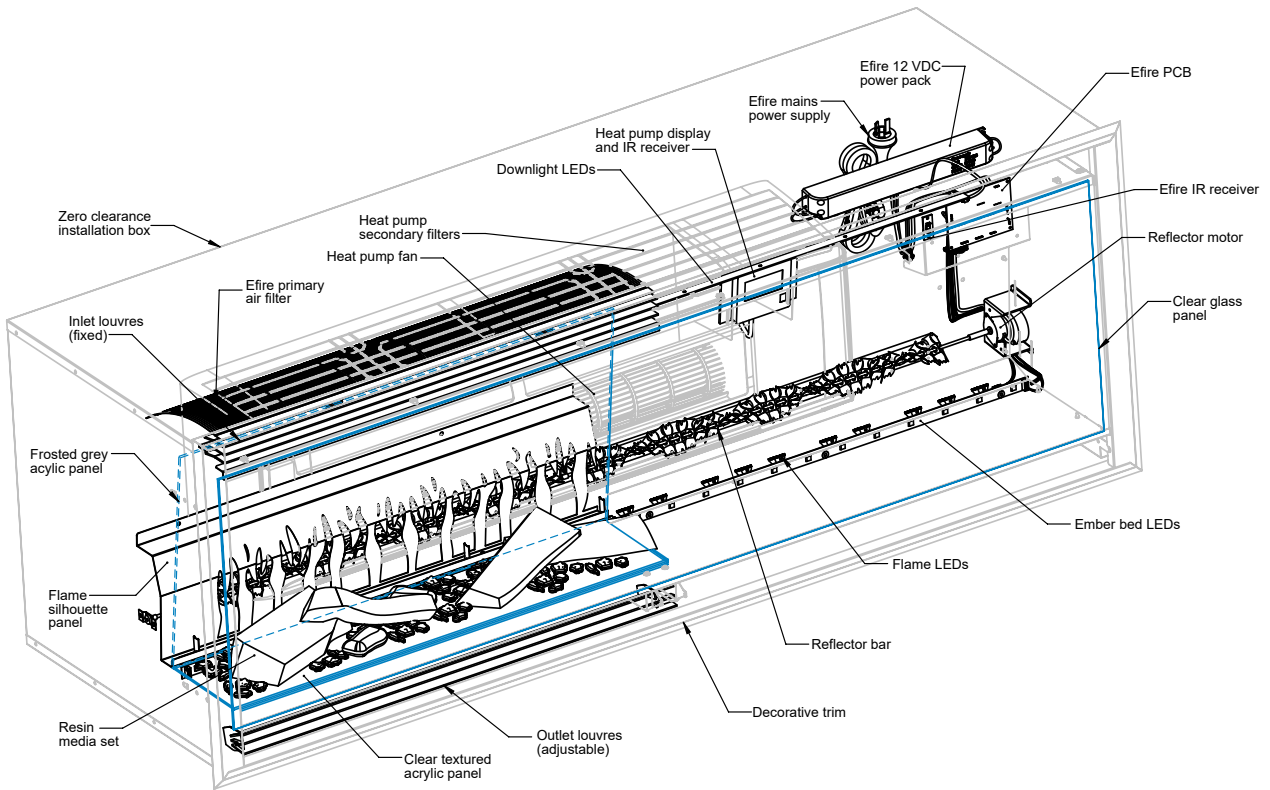

Appliance location

The heat pump component of this system contains R32 refrigerant. It **MUST BE** installed, operated and stored in a room with a **floor area larger** than 14m².

The system is suitable for indoor applications only. **DO NOT** install near a wet area such as a bath, shower, or swimming pool.

The individual components of the system must be installed on a surface capable of supporting its weight. Improper installation or placement on an inadequate surface may create unsafe operating conditions, leading to injury or damage.

The installer must install drainage piping, for the heat pump, according to the installation instructions. Improper drainage may cause water damage to the property.

- Do not install the unit in location that may be exposed to combustible gas leaks. If combustible gas accumulates around the unit, it may cause a fire.
- Do not install the outdoor unit where noise may cause a nuisance, such as near bedrooms or neighbouring properties.
- Do not install the outdoor unit where it will be exposed to sea wind and salt spray, this will significantly reduce the durability of the unit.

Recommended installation height

200-400 mm from the floor.

Installing the unit lower can result in cold air flowing along the floor during cooling mode, which may cause drafts and discomfort.

The main considerations when positioning the unit are:

- Ensuring the room size requirements noted above.
- Allowing sufficient access for ease of operation, servicing, and removal of the appliance.
- Ensuring access to the isolating switch outside the cavity.

DO NOT install in a corner as the depth required for the installation will significantly affect the performance of the system.



The Velare 1500 is designed primarily for flush installations with the outer trim covering the fixings of the zero clearance box. If recessed, removal of the trim for access and servicing may be difficult. If the design requires the unit to be recessed, we recommend a maximum of 200 mm, this is because of the importance of ensuring only room air circulates through the appliance.

Clearances

This appliance must not be installed where curtains or other materials could come into contact or in close proximity potentially blocking the inlet or outlet louvres. In some cases curtains may need restraining.

Due to the unit's lower air discharge, there are no specific non-combustible framing or cladding requirements, and no minimum clearance requirements to the sides or above. A TV, mantel, or other interior feature may be installed directly above the unit.

A front clearance of 1000 mm is recommended to ensure optimal viewing, user comfort, and to minimise the effect of air movement, particularly during the cooling cycle. The unit should be installed 200–400 mm above floor level (refer to note on previous page).

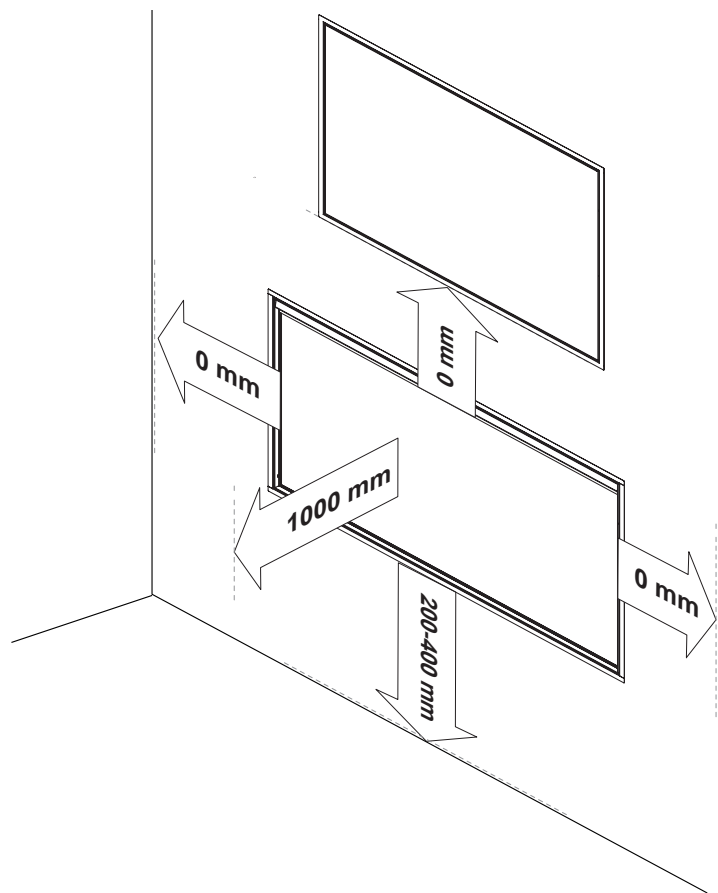

Floor protection

Heat discharged from the unit may affect the appearance of some flooring materials, including vinyl planks, carpet, cork, and timber. Where sensitive materials are present, it is recommended that a protective mat be placed in front of the appliance.

Hearth

A hearth may be used for decorative purposes but must not obstruct or cover any part of the unit. The outer trim must also remain easily removable to allow access for servicing.



Please note that condensation may form on stone or similar hearth materials when the unit is set to cooling.

Installation overview

Construct enclosure, ensuring that it is a sealed cavity.



1

Remove the zcb from the box, assemble and install. It is critical it is installed on a flat surface and that it is square.



2

Install heat pump system. The indoor unit must be level and have even spacing either side. Install the LED display.



3

Remove the electric fire from the box and place in front of the opening. Remove glass, media, and filters. Position fire in enclosure.

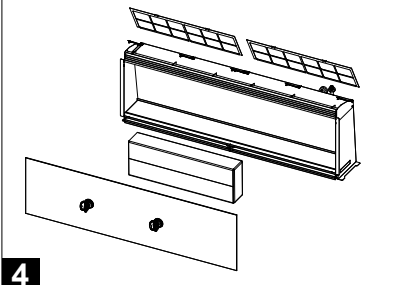

4

Secure the fire by attaching to the four brackets inside the zero clearance box.



5

Install the trim. rest the bottom edge of the trim on the unit, centralise and click into place.



6

Install the filters. The two filters slide into the angled stainless steel bars at the top of the fire.



7

Power on and test. Use the green button on the remote to turn the fire on. Check that it functions correctly.



8

Arrange logs and granules, this can be adjusted based on personal preference.



9

Front glass installation. Using the two glass suction cups provided, angle the top edge in first, then swing from the bottom edge into the channel.

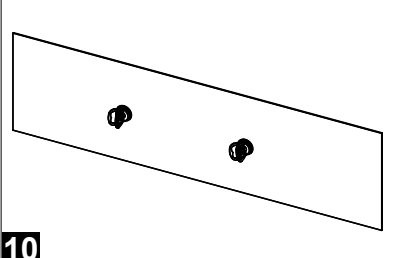

10

Before starting

The electric fire, front trim, and zero clearance box (zcb) come packaged together in one large carton with dividers.



Unpack the appliance and components, and remove all transit packaging. Check for damage. DO NOT install any damaged items. If the mains power supply lead is damaged in any way, it MUST be replaced by a genuine Rinnai replacement part. Check all components have been supplied.

If installing the electric fire at a later date the fire and trim can be put back in the box.

Read these instructions to get an overview of the steps required before starting the installation. Failure to follow these instructions could cause a malfunction of the appliance. This could result in serious injury and/or property damage.

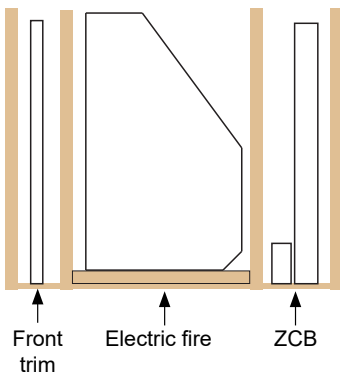

Unpacking the Velare for installation:

1. Remove the preinstalled filters.
2. Remove the front glass by attaching the supplied suction cups, then lifting up and swinging the bottom edge outwards and dropping down.
3. Remove media box.

Included in the box:

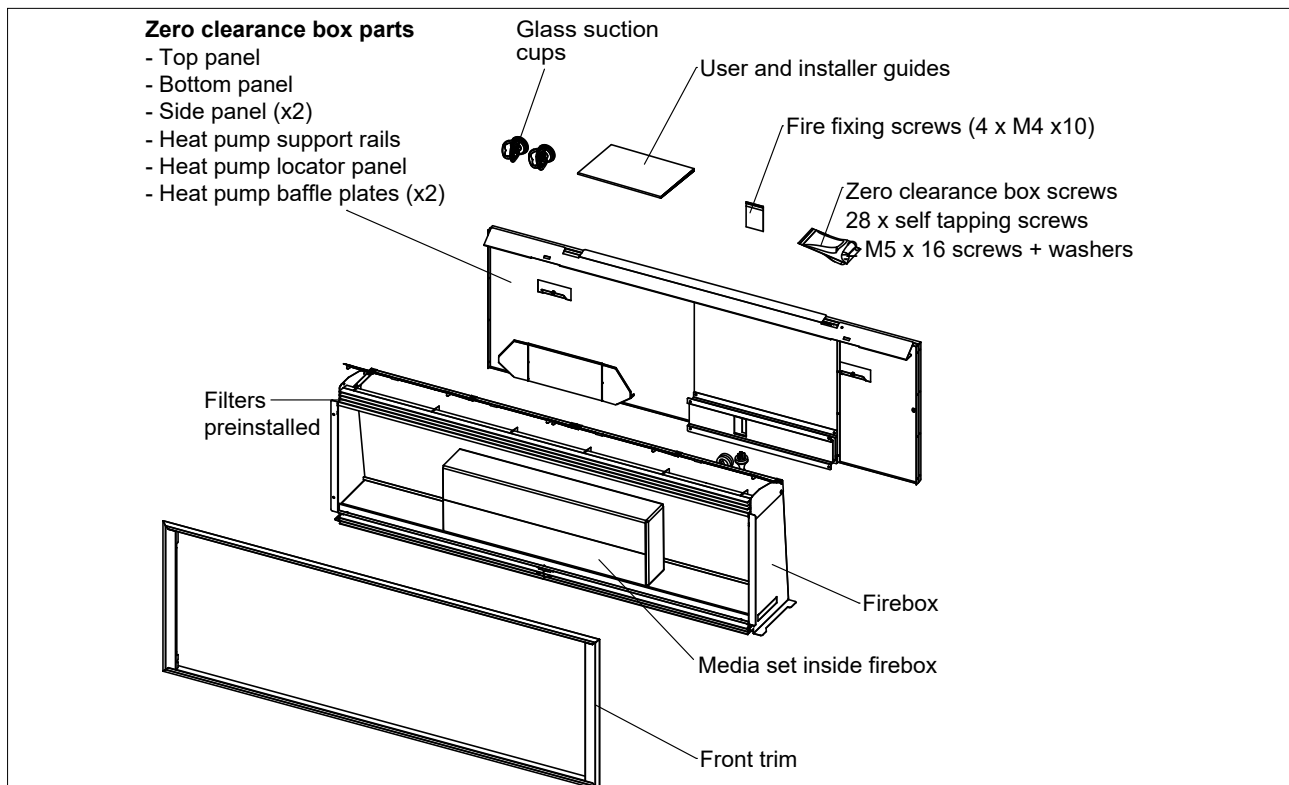

Due to the size and weight distribution, two people may be required to install the system components into the enclosure.

Enclosure and framing details

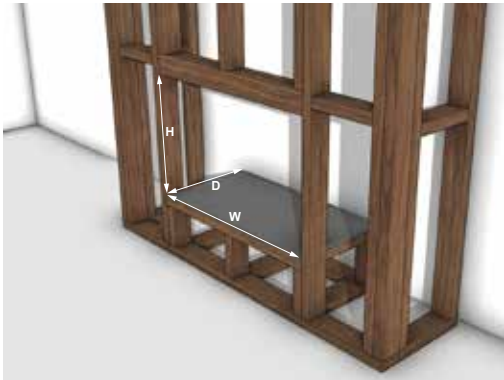

Dimensions (mm)	
Height	510 ¹ -515
Width	1510-1520
Depth	505 mm min. 550 mm recommended to allow for pipes behind heat pump

¹ Refer lintel notes below

Recommended installation height

200–400 mm from the floor. Installing the unit lower can result in cold air flowing along the floor during cooling mode, which may cause drafts and discomfort.



It is important to install the system in a **SEALED CAVITY** to ensure only room air circulates, rather than air from other areas such as the ceiling or outdoors.

For new builds make sure the cavity where the fire is installed is not exposed to insulation or construction dust and debris—ensure the back of the enclosure is not left unlined.

Wall linings

When building the enclosure it's important to allow for the thickness of the wall lining, the outer edge of the zero clearance box needs to be flush with the wall lining. Because warm air is discharged through the lower louvres, the wall linings around and above the unit can be made from any material. No special clearances or non-combustible materials are required.

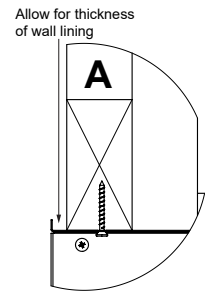

It is critical that the installation cavity is **SEALED** so that only room air can enter the fire through the front louvres. If air is being drawn from the roof space, for example, the heat pump will not operate as intended.

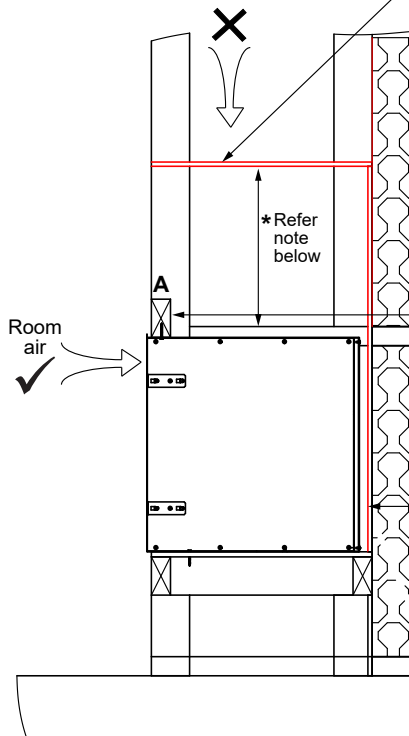

If the ZCB is to be installed **AFTER** the wall lining, allow extra room to install it, and place **packers** between the lintel and the ZCB to make sure the box is flat. This is important for fitting the trim, and the filters.

If the zero clearance box (ZCB) is installed **BEFORE** the wall lining, it is recommended that the top lintel is installed tight on top of the ZCB.

Ensure the cavity where the unit is installed is not exposed to insulation or construction dust—the back of the cavity must be lined

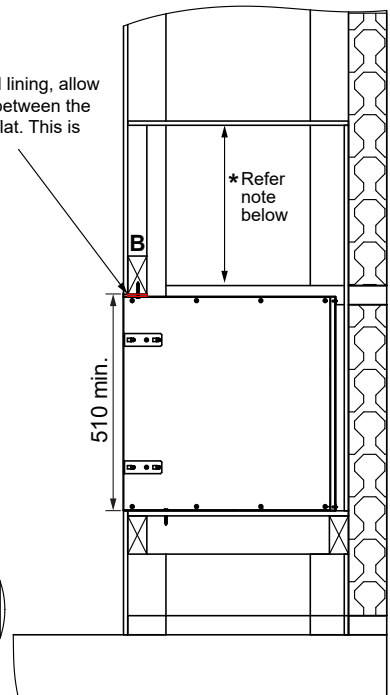
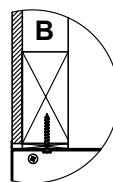
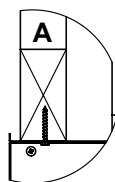

* This dimension does not matter. Its intention is to highlight that the cavity needs to be sealed—there is no clearance requirement.

Refrigerant piping zones

Running refrigerant piping straight out through the lower right hand side is an easier and safer approach, keeping all connections outside the home.

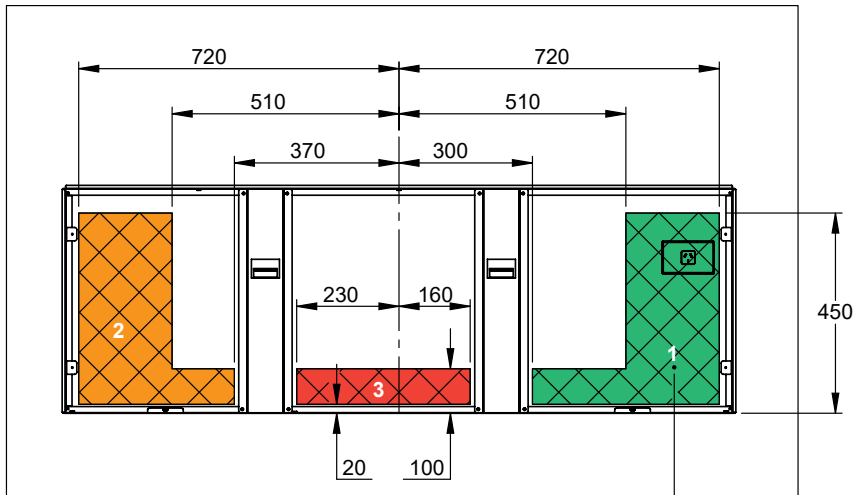

- 1. Preferrable location
- 2. Left hand side, second option
- 3. Behind, least favourable

Ø60-75 mm hole for refrigerant and heat pump power. Lower right hand side is preferable for ease of installation.

Electric fire power supply

The electric fire requires its own independent power supply. The below diagram with the cross hatch fill shows the zone in which the electrical connection can be installed. Ensure this connection has been made before installing the electric fire.

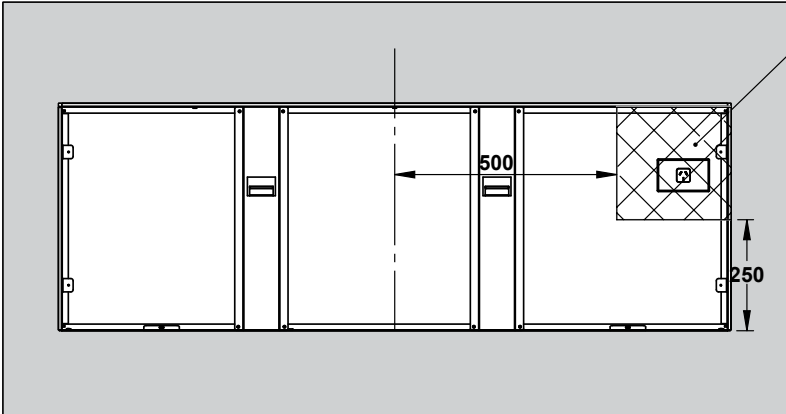

230 V AC 10 A dedicated earthed electric fire power supply. A separate isolating switch must be accessible outside of the cavity.



Electric fire, example of a separate external isolating switch outside the cavity. It may be installed in any position, provided it remains easily accessible.

Electric fire, dedicated earthed power point
Heat pump, outdoor isolating switch

Installation

Ensure zero clearance box is square and on a flat surface otherwise the electric fire won't screw into position.

To make the unit easier to manoeuvre you can remove the front glass, logset, and other items packaged inside the unit. To remove the glass use the supplied suckers, lift the glass up and swing the bottom edge out, then drop down. Place carefully aside.

Ensure the foam strip is fitted to the back of the firebox prior to installation. This component is critical to system performance because it stops air from circulating up around the unit.

The gap between the heat pump and electric fire when installed is approximately 8 mm.



1. Position the fire

Remove the electric fire from the box, and place it in front of the opening. Before fitting the firebox into the zero clearance box.

- a. Remove the front glass. Fit the suction cups to the front glass. Lift glass up and swing the bottom edge out until clear of the firebox, then drop down out of the top channel. Place the glass in a location where it cannot fall or be damaged.
- b. Remove burn media set.
- c. Remove the two filters from the top of the box.

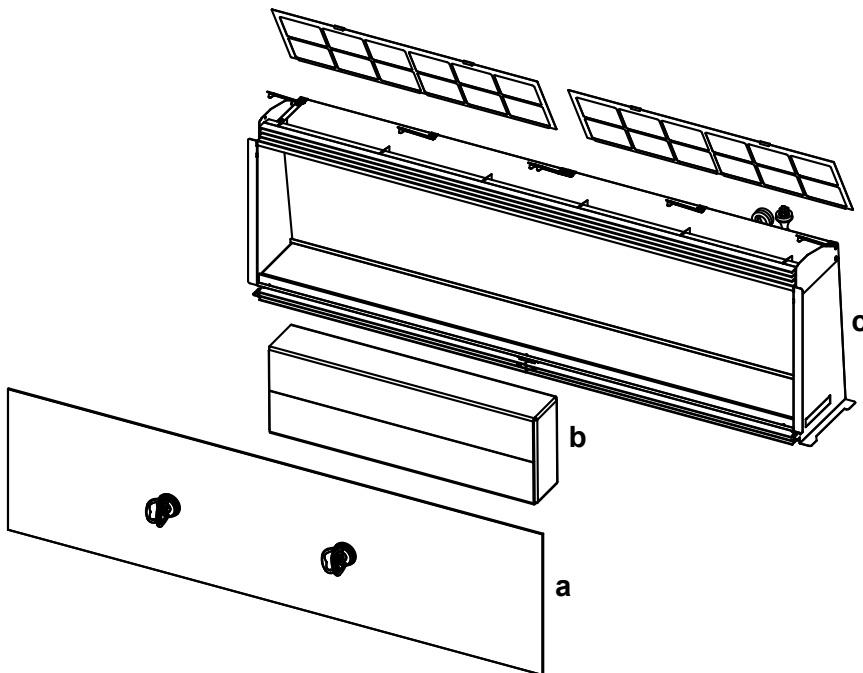

2. Insert and connect

Position the fire by lifting and sliding it into place. Connect the power supply and ensure it is switched on. With the unit in standby, press and hold the blank button on the remote for more than three seconds to initiate and check the full LED sequence.



3. Secure the fire

Attach the fire to the four brackets inside the zero-clearance box using the supplied screws.

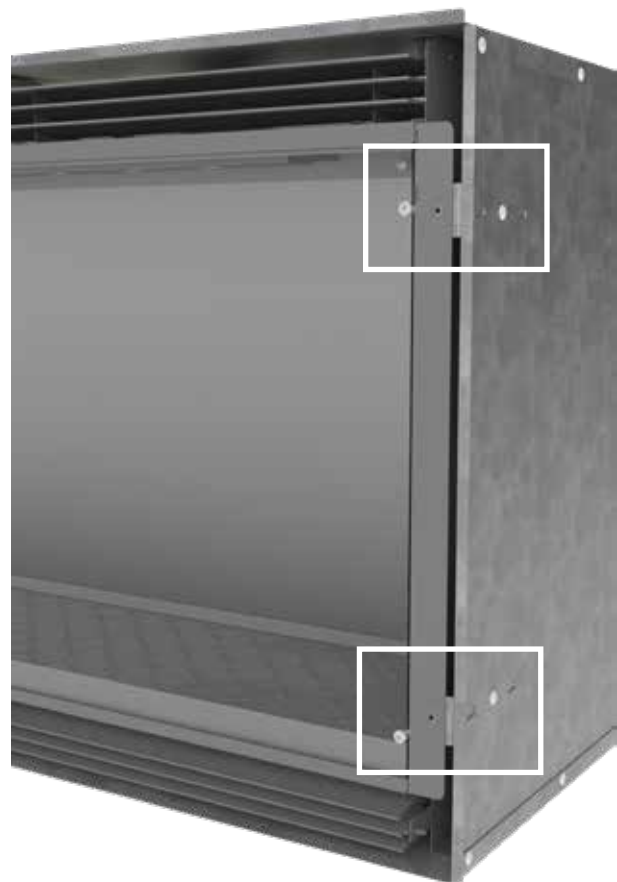

4. Install the trim

Rest the bottom edge of the trim on the unit. Centralise the trim and click it into place. The trim is held securely by magnets.



5. Install filters

The two filters are pre-installed inside the firebox and should have been removed at the start of installation. Reinstall them only after the trim has been fitted; installing them earlier will prevent the trim from seating correctly. The filters slide into the angled stainless steel bars at the top of the fire. The tab hooks need to face down otherwise they won't go all the way in.



6. Power on and test

Use the green button on the remote to turn the fire on. Check that it functions correctly.

Media setup



Velare 1500 media set



The media set comes packaged inside the electric fire. It consists of:

- Seven logs and two large twigs.
- Three large dark granules, and one packet (approx. 500 g) of dark coloured light weight translucent granules, the granules help diffuse the light for a softer, more natural glow.

The above photo is a recommended layout, but it can be freely adjusted based on personal preference. For example, the logs may have the bark side up or the burnt side up, or a mix of both.

An optional pinecone accessory kit (R2906) is available (purchased separately) to customise your display.



Front glass installation

The anti reflective glass is held in place by a top and bottom channel. It comes preinstalled in the unit but as it was removed prior to installation it needs to be put back in.



Clean the inside of the glass (using a soft cloth only) prior to refitting.

Using the two glass suction cups provided to lift the glass. Angle the top edge in first, then swing the bottom edge into the channel. Remove the suction cups and clean the outside of the glass.



Check appliance operation

Test the appliance using the remote to ensure all operational modes work. If the appliance cannot be made to perform correctly please contact Rinnai.

Installation checklist and customer handover

Complete the installation checklist in the customer operation guide and leave the guide with the customer. Take the time to explain about the use and care of the unit, including recommended servicing.

Wiring layout

- Power supply: 230 V / 12 V
- Control PCB: 12 V
- Motor: 12 V DC
- LED strip downlights
- LED strip back lights
- LED strip ember bed lights

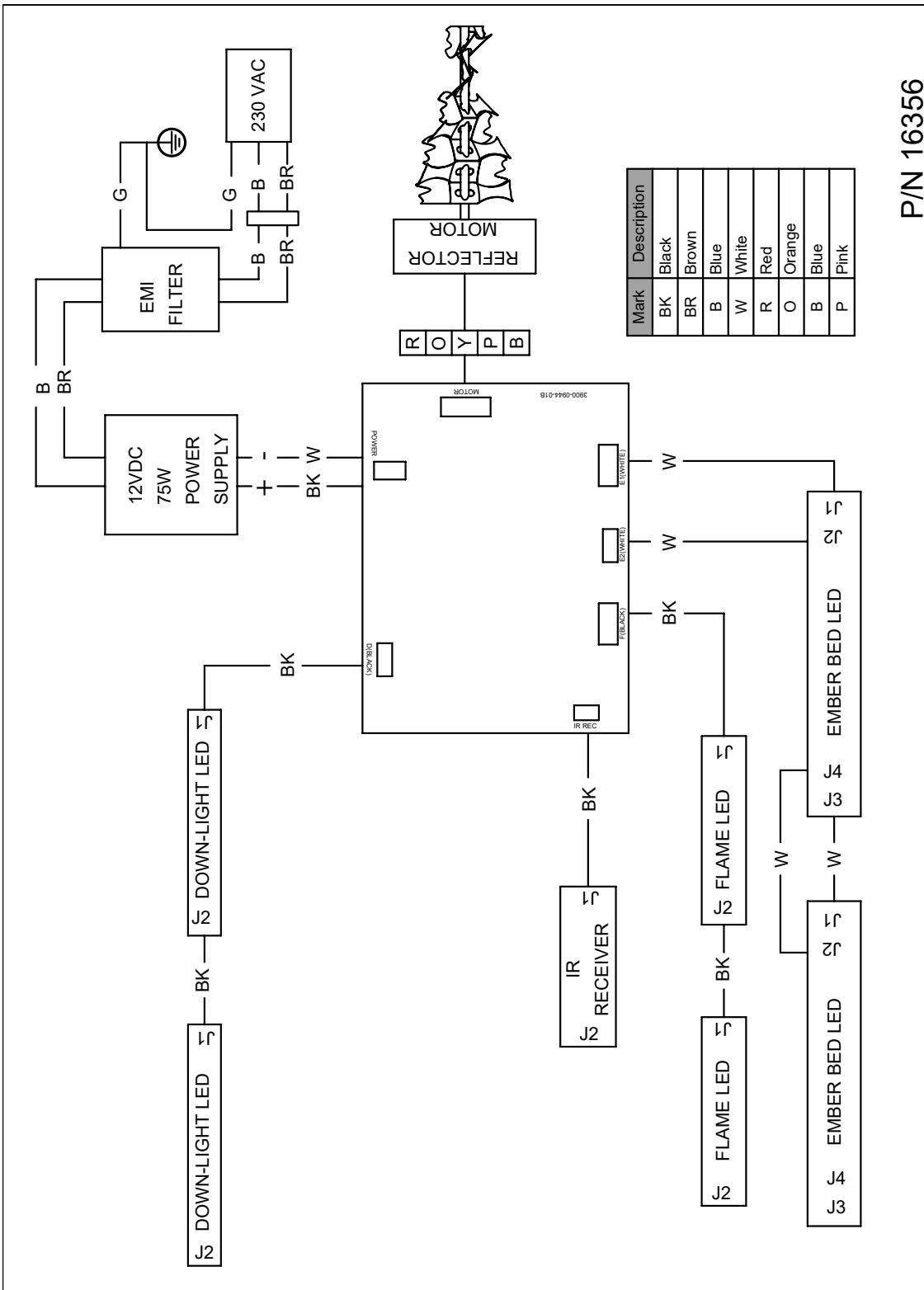

P/N 16356

Rinnai.co.nz

Tel: 0800 746 624
<http://www.youtube.com/rinnainz>
<http://facebook.com/rinnainz>

Velare 1500 Firebox installation guide
16362-B