

MODELS:

**System**

7 - DSNSR07B1LA  
9 - DSNSR09B1LA  
11 - DSNSR11B1LA  
13 - DSNSR13B1LA  
15 - DSNSR15B1LA (non-splittable)  
15 - DSNSR15B1TA (splittable)  
18 - DSNSR18B1TA (splittable)

**Indoor**

DINLR07B1A  
DINLR09B1A  
DINLR11B1A  
DINLR13B1A  
DINLR15B1NA  
DINLR15B1SA  
DINLR18B1SA

**Outdoor**

DONSR07B1LA  
DONSR09B1LA  
DONSR11B1LA  
DONSR13B1LA  
DONSR15B1LA  
DONSR15B1TA  
DONSR18B1TA



# Pro Series Ducted Central Heating & Cooling Systems

## Installation guide

# Rinnai

---

# Important

---

This appliance must be installed in accordance with:

- Manufacturer's installation instructions
- Current AS/NZS 3000, AS/NZS 3500 National Plumbing & Drainage, AS/NZS 5141, AS/NZS 5149, AS/NZS 1677, AS/NZS 60335.2.40, and G12/AS1
- HB276 - A Guide to good practice for energy efficient installation

This appliance must be installed, maintained and removed only by an authorised person.

The system is not suitable for commercial applications requiring a controlled atmosphere, for example server rooms, food storage etc.

For continued safety of this appliance it must be installed and maintained in accordance with the manufacturer's instructions.

## **Warning**

Improper installation, adjustment, alteration, service and maintenance can cause property damage, personal injury or loss of life.

For more information about buying, using, and servicing of Rinnai appliances call: 0800 RINNAI (0800 746 624).

Rinnai New Zealand Limited  
105 Pavilion Drive, Mangere, Auckland  
PO Box 53177, Auckland Airport, Auckland 2150

Phone: (09) 257-3800  
Email: [info@rinnai.co.nz](mailto:info@rinnai.co.nz)  
Web: [rinnai.co.nz](http://rinnai.co.nz)  
[youtube.com/rinnainz](https://www.youtube.com/rinnainz)  
[facebook.com/rinnainz](https://www.facebook.com/rinnainz)

---

# Contents

---

Safety and important information.....	4
Specification summary .....	6
System components .....	8
Installation summary.....	9
Indoor unit installation.....	10
Indoor unit installation - hanging bolts .....	14
Indoor unit installation - drainpipe.....	15
Outdoor unit installation - location .....	18
Outdoor unit installation - mounting dimensions...20	
Refrigerant piping connection.....	21
Wiring and controllers.....	24
Power and communication connections .....	25
Outdoor unit wiring .....	26
Indoor unit wiring .....	28
Pressure and leak test.....	29
Evacuation.....	30
Test run.....	31
Fan performance charts .....	33
Setting the system static pressure.....	39
Error code summary .....	40
Wired wall controller: Queries and settings .....	41
Wiring diagrams.....	43



Images in this guide are for illustration purposes. The system purchased may be slightly different in design.

# Safety messages / important information



This appliance is heavy, use two people or a mechanical lifting device. Improper lifting may result in serious injury.

For safety and warranty, appliances that are damaged **MUST NOT** be installed or operated under any circumstances.

## Electrical warnings



**DO NOT** modify the electrical wiring of this appliance. If the control power wiring is damaged or deteriorated then it must be replaced by an authorised person. Failure to do so may result in electric shock, fire, serious injury, or product failure.

All electrical connections **MUST** be made according to the wiring diagrams located on the panels of the indoor and outdoor units.

The PCB is designed with a fuse to provide overcurrent protection. The specifications of the fuse are printed on the PCB. For units using R32 refrigerant, only a blast-proof ceramic fuse can be used.

Power voltage should be within 90-110% of rated voltage. Insufficient power supply can cause a malfunction, electrical shock, or fire.

Only connect the unit to an individual branch circuit outlet. **DO NOT** connect another appliance to that outlet.

## Electrical wires

This a Class 1 electrical appliance. Make sure the live wire, neutral wire, and earth wire in the power socket are properly connected. Inadequate or incorrect electrical connections may cause fire or electric shock.

The yellow-green wire in the air conditioner is the earthing wire which cannot be used for any other purpose. Improper earthing may cause electric shock. The unit must be earthed in accordance with local regulations.

Every wire must be firmly connected. Loose wiring can cause the terminal to overheat, resulting in a product malfunction and possible fire.

Do not let live wires touch or rest against refrigerant tubing, the compressor, or any moving parts within the unit.

## Circuit breaker

The circuit break must have the functions of magnetic tripping and heat tripping to prevent short circuiting and/or overload. Use a standard circuit breaker and fuse conforming with the rating of the appliance.

## Fixed wiring

If connecting power to fixed wiring<sup>1</sup>:

- A surge protector and mains power switch should be installed.
- A switch or circuit breaker that disconnects all poles and has a contact separation of at least 1/8" (3 mm) must be incorporated in the fixed wiring.

<sup>1</sup> Consult a qualified electrician as it must comply with AS/NZS 5601 and AS/NZS 3000 and other relevant local regulations.

## R32 refrigerant

This appliance uses R32 (difluoromethane) refrigerant, which is a flammable gas class A2L according to AS 5149.1 and MUST BE handled by a refrigerant mechanic with the appropriate refrigerant handling licence.



Warning risk of fire / flammable material. If the refrigerant is leaked, together with an ignition source, there is a possibility of ignition.

## Minimum room sizes

When flammable refrigerants are used the appliance shall be located in a well ventilated area where the room size corresponds to the room area as specified for operation, refer table below.

Please ensure that these minimum room sizes are adhered to for standard installations (up to 15 m pipe length). If larger refrigerant charges than standard are used the installer must consult AS/NZS 60335.2.40 to determine the safe minimum floor area for the installation. Minimum room sizes are calculated on the base charge provided with the outdoor unit.

Model	DONSR07B1LA	DONSR09B1LA	DONSR11B1LA	DONSR13B1LA	DONSR15B1LA	DONSR15B1TA	DONSR18B1TA
Standard charge (g)	1500	2600	2600	3500	3500	3600	3800
Min. floor area (m <sup>2</sup> )	1.42	4.28	4.28	7.75	7.75	8.20	9.14

## Minimum room areas for wall mounted vertical installs - 7 and 9 models only

Vertical install	Model	DONSR07B1LA	DONSR09B1LA
Height (m)	Standard charge (g)	1500	2600
0.6	Min. floor area (m <sup>2</sup> )	19.4	58.1
0.7		14.2	42.7
0.8		10.9	32.7
0.9		8.6	25.8
1.0		7.0	20.9

## Location and positioning

Installation must be in a position that can support the unit's weight. If the chosen location cannot support the weight of the unit, or the installation is not done properly, the unit may drop and cause serious injury or damage.

The installer must install drainage piping according to the installation instructions. Improper drainage may cause water damage to your home or property.

- Do not install the unit in location that may be exposed to combustible gas leaks. If combustible gas accumulates around the unit, it may cause a fire.
- Do not install the outdoor unit where noise may cause a nuisance, such as near bedrooms or neighbouring properties.
- Where possible do not install the outdoor unit where it will be exposed to sea wind and salt spray, this will significantly reduce the durability of the unit.

## Disposal guidelines

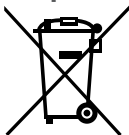

This appliance contains refrigerant and other potentially hazardous materials. When disposing of this appliance, the law requires special collection and treatment. DO NOT dispose of this product as household waste or unsorted municipal waste.

# Specification summary

RINNAI SYSTEM / NOMINAL CAPACITY (kW)			7	9	11	13
Power supply (to outdoor unit)		V-Ph-Hz	220 - 240 - 1 - 50			
Maximum input power		W	3400	4600	4600	7000
Maximum input current		A	16	21	21	31
COOLING	Rated capacity	kW	7.3	9.0	10.5	12.6
	Capacity range	kW	0.85~9.09	2.30~11.61	2.61~11.99	3.15~15.80
	Rated input power	W	2139	2610	3145	3765
	Rated input current	A	9.3	11.9	14.1	16.6
	AEER	WW	3.39	3.40	3.30	3.32
	TCSPF (hot/average/cold)	WW	6.080 / 5.510 / 5.848	5.817 / 5.114 / 5.316	5.935 / 5.241 / 5.501	5.813 / 5.240 / 5.503
HEATING	Rated capacity	kW	7.5	10.5	12.5	14.5
	Capacity range	kW	2.33~10.26	2.70~12.90	2.61~12.90	3.22~18.70
	Rated input power	W	1842	2400	2980	3550
	Rated input current	A	8.2	10.6	13.5	15.4
	ACOP	WW	4.04	4.30	4.14	4.05
	HSPF (hot/average/cold)	WW	5.158 / 4.501 / 4.045	5.180 / 4.627 / 4.081	5.221 / 4.500 / 3.842	5.110 / 4.515 / 4.022
<b>INDOOR UNIT</b>						
Rated input		W	256	350	364	665
Wiring indoor - outdoor		Qty x mm <sup>2</sup> (min)	4 x 1.0	4 x 1.0	4 x 1.0	4 x 1.5
Air flow	Turbo speed	L/s (ESP)	488 (100 Pa)	638 (100 Pa)	727 (100 Pa)	920 (150 Pa)
Maximum external static pressure		Pa	160	160	200	200
Noise level	Sound pressure @1.5m (turbo/hi/med/lo/silence)	dB(A)	41 / 38 / 36 / 33 / 28	46 / 40 / 38 / 36 / 28	45 / 39 / 38 / 36 / 30	52 / 46 / 44 / 42 / 34
	Sound power level	dB(A)	59.9	58.3	57.7	62.0
Dimensions	Net (W x D x H)	mm	1000 x 750 x 245	1200 x 750 x 245	1200 x 750 x 300	1200 x 750 x 300
	Packaging (W x D x H)	mm	1225 x 860 x 304	1425 x 860 x 304	1425 x 860 x 359	1425 x 860 x 359
	Net / gross weight	kg	32 / 38	41 / 47	43 / 50	45 / 52
Condensate drain pipe outer diameter	Gravity	mm	25			
	Pump		25			
Moisture removal		L/h	2.95	2.68	1.92	3.56
Controller		Type	Wired programmable controller with Wi-Fi control			
Operating range		°C	Cooling: 16~32, heating: 0~30			
<b>OUTDOOR UNIT</b>						
Power supply		V-Ph-Hz	220 - 240 - 1 - 50			
Compressor		Type	Twin rotary			
Sound pressure level @1m		dB(A)	61	62	62	64
Sound power level		dB(A)	66.3	68.1	68.1	70.7
Dimensions	Net (W x D x H)	mm	890 x 342 x 673	946 x 410 x 810	946 x 410 x 810	980 x 415 x 975
	Packaging (W x D x H)	mm	1030 x 438 x 815	1090 x 500 x 965	1090 x 500 x 965	1145 x 500 x 1120
	Net / gross weight	kg	44 / 58	75 / 92	75 / 92	89 / 103
Refrigerant piping	Type		R32			
	Charged volume	kg	1.5	2.6	2.6	3.5
	Design pressure	MPa	4.3 / 1.7	4.3 / 1.7	4.3 / 1.7	4.3 / 1.7
	Pre-charged length	m	20			
	Change adjust. if >20m	g/m	24			
	Liquid / gas connections	mm	9.5 / 15.9	9.5 / 15.9	9.5 / 15.9	9.5 / 15.9
	Maximum pipe length	m	50	75	75	75
	Minimum pipe length	m	3	3	3	3
Max. vertical separation	m	25	30	30	30	
Ambient temperature limits		°C	Cooling: -15~50, heating: -20~24			

Note: For pipe runs less than 20 m one way, no refrigerant needs to be removed, if greater than 20 m refrigerant will need to be add at 24 g/m.

RINNAI SYSTEM / NOMINAL CAPACITY (kW)			15 non-splittable	15 splittable	18 splittable
Power supply (to outdoor unit)		V-Ph-Hz	220 - 240 - 1 - 50		
Maximum input power		W	7000	7000	7000
Maximum input current		A	31	31	31
COOLING	Rated capacity	kW	14	14	17
	Capacity range	kW	3.22~16.10	4.19~18.17	3.60~19.34
	Rated input power	W	4250	3900	5100
	Rated input current	A	18.8	17	22
	AEER	W/W	3.27	3.56	3.31
	TCSPF (hot/average/cold)	W/W	5.685 / 5.148 / 5.407	6.002 / 5.425 / 5.676	5.550 / 5.085 / 5.341
HEATING	Rated capacity	kW	16.0	17.0	18.0
	Capacity range	kW	3.22~18.70	3.60~19.60	3.90~19.60
	Rated input power	W	4100	4180	4560
	Rated input current	A	18.1	18.5	20.0
	ACOP	W/W	3.87	4.04	3.92
	HSPF (hot/average/cold)	W/W	5.070 / 4.391 / 3.827	5.178 / 4.501 / 3.920	5.005 / 4.317 / 3.720
<b>INDOOR UNIT</b>					
Fan motor rated input		W	560	560	560
Wiring indoor - outdoor		Qty x mm <sup>2</sup> (min)	4 x 1.5	4 x 1.5	4 x 1.5
Air flow	Turbo speed	L/s (ESP)	922 (150 Pa)	922 (150 Pa)	925 (150 Pa)
Maximum external static pressure		Pa	200	200	200
Noise level	Sound pressure @1.5m (turbo/hi/med/lo/silence)	dB(A)	52 / 46 / 44 / 42 / 34	50 / 47 / 44 / 42 / 36	51 / 49 / 47 / 43 / 36
	Sound power level	dB(A)	64.6	62.2	61.9
Dimensions	Net (W x D x H)	mm	1200 x 750 x 300	1400 x 870 x 380	1400 x 870 x 380
	Packaging (W x D x H)	mm	1425 x 860 x 359	1650 x 1065 x 477	1650 x 1065 x 477
	Net / gross weight	kg	45 / 51.9	65 / 80.9	67 / 81.9
Condensate drain pipe outer diameter	Gravity	mm	25		
	Pump		25		
Moisture removal		L/h	4.42	4.45	4.36
Controller		Type	Wired programmable controller with Wi-Fi control		
Operating range		°C	Cooling: 16~32, heating: 0~30		
<b>OUTDOOR UNIT</b>					
Power supply		V-Ph-Hz	220 - 240 - 1 - 50		
Compressor		Type	Twin rotary		
Sound pressure level @1m		dB(A)	64	65	63
Sound power level		dB(A)	70.8	70.8	71.6
Dimensions	Net (W x D x H)	mm	980 x 415 x 975	952 x 415 x 1333	952 x 415 x 1333
	Packaging (W x D x H)	mm	1145 x 500 x 1120	1095 x 495 x 1500	1095 x 495 x 1500
	Net / gross weight	kg	89 / 103	93 / 110	94 / 110
Refrigerant piping	Type		R32		
	Charged volume	kg	3.5	3.6	3.8
	Design pressure	MPa	4.3 / 1.7	4.3 / 1.7	4.3 / 1.7
	Pre-charged length	m	20		
	Change adjust. if >20m	g/m	24		
	Liquid / gas connections	mm	9.5 / 15.9	9.5 / 15.9	9.5 / 19.1
	Maximum pipe length	m	75	75	75
	Minimum pipe length	m	3	3	3
Max. vertical separation	m	30	30	30	
Ambient temperature limits		°C	Cooling: -15~50, heating: -20~24		







Note: For pipe runs less than 20 m one way, no refrigerant needs to be removed, if greater than 20 m refrigerant will need to be add at 24 g/m.

# System components



The ducted system comes in a number of boxes along accessories—DO NOT throw these away as these parts are required for installation. Improper installation may result in water leakage, electrical shock and fire, or cause the equipment to fail. **Please note:** Wired controllers are sold separately.

## Accessories

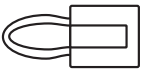
### Indoor unit

<p>Display control</p> 	<p>Pipe protection covers</p> 
<p>2 m wiring loom</p>  <p>Allows the display control to be installed in a more accessible location</p>	<p>Pipe connections</p> 
<p>Cable ties</p> 	<p>Magnetic rings</p> 
<p>CN5 bypass connector</p>  <p>For gravity condensate drain installations</p>	

### Outdoor unit

<p>Drain plug and seal</p> 	<p>Magnetic rings</p> 
---	---

# Installation summary

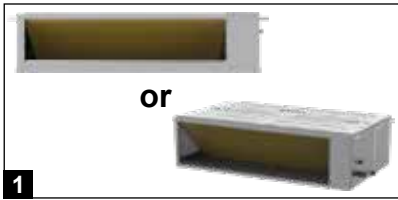

1 Install the indoor unit<sup>1</sup>.

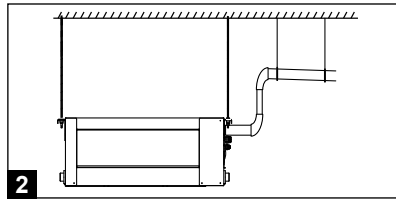

2 Install the drain pipe.

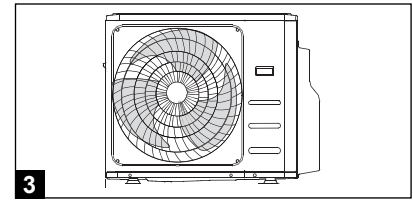

3 Install the outdoor unit.

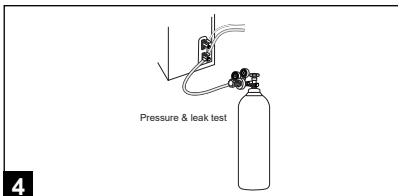

4 Pressure test and leak test.

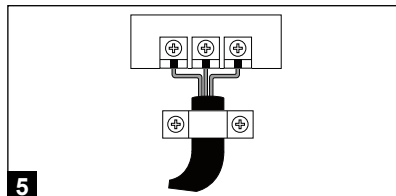

5 Connect the wires.

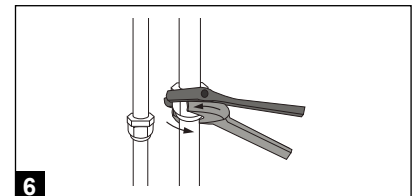

6 Connect the refrigerant pipes.

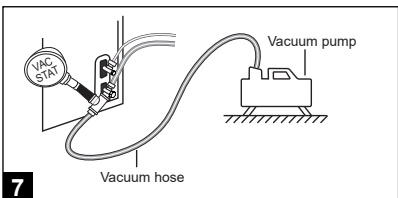

7 Evacuate the system.

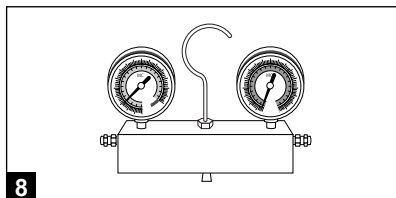

8 Charge the system.

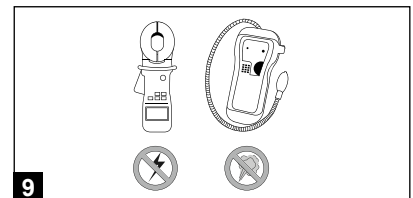

9 Perform a test run.

Before installing the indoor unit, ensure the location is suitable:

- There needs to be enough room for installation, maintenance and service (refer diagram below), and for connecting the pipe and drain pipe.
- The unit is installed level and the structure can support the weight of the indoor unit.
- The air inlet and outlet are unobstructed.
- The airflow rates and heating / cooling capacity are suitable.
- There is no direct radiation from a heat source.

DO NOT install in the following locations:

- Under a floor or beneath a deck, to be installed in a roof space only
- Enclosed spaces such as cabinets
- Areas that experience power fluctuations, such as factories
- Coastal areas with high salt content in the air
- Areas with caustic gases in the air, such as hot springs
- Kitchens that use natural gas or LPG
- Areas with strong electromagnetic waves
- Areas that store flammable materials or gas
- Rooms with high humidity, such as bathrooms or laundry rooms

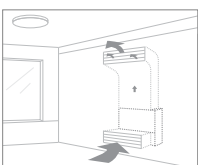

<sup>1</sup> The 7–9 models can be installed vertically, refer following pages from more detail. Vertical installations must comply with the minimum indoor floor space requirements specified in AS/NZS 60335.2.40.

# Indoor unit installation



All fasteners, washers, brackets, support members and vibration mounts required to hang the unit are field supplied.

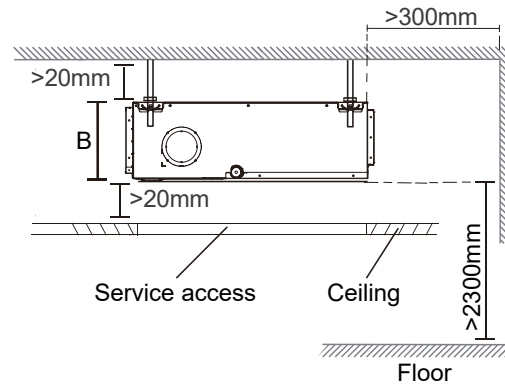
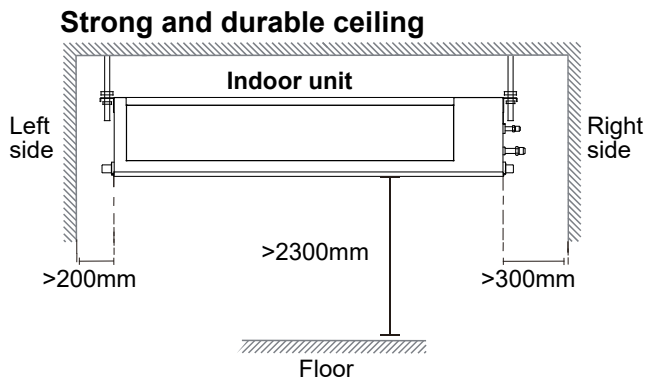

## Vertically wall mounted (7 and 9 models only)

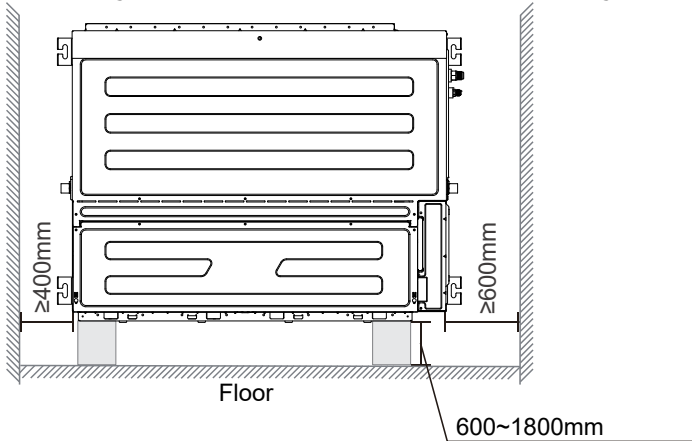

## Maintenance space

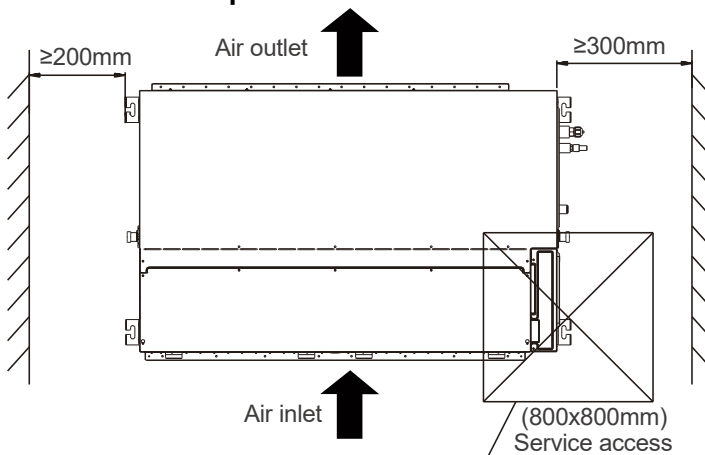

### Safety tray and drain

- Always install a safety drain tray (field supplied)
- The safety drain tray should be independently drained
- Terminate the safety drain tray in a position so as not to cause a nuisance, and where the homeowner can see if water is dripping.
- Instruct the owner to contact installer or Rinnai if the safety drain tray outlet drips water

## Hang indoor unit: 7-13 models

Refer to the following diagrams to locate the four positioning screw bolt holes on the ceiling. Be sure to mark the places where you will drill ceiling hook holes.

**Air outlet dimensions**

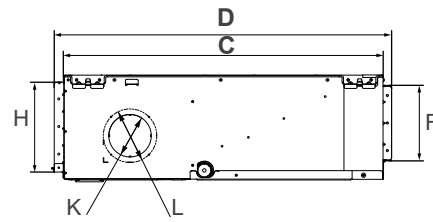
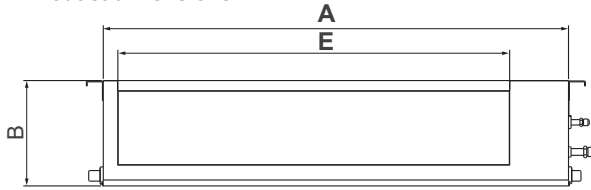

**Air inlet dimensions**

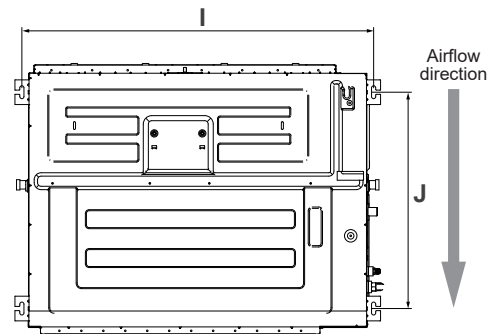
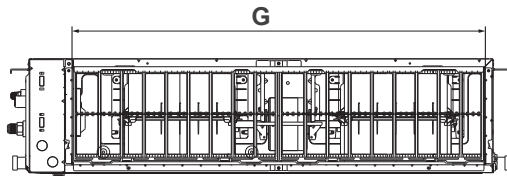

Model	Outline dimension (mm)				Air outlet opening size (mm)		Air return opening size (mm)		Dim. of moulded lug (mm)		Fresh air intake opening size (mm)	
	A	B	C	D	E	F	G	H	I	J	K	L
7	1000	245	750	795	827	178	892	212	1040	640	100	126
9	1200	245	750	795	1027	178	1092	212	1240	640	100	126
11 / 13	1200	300	750	795	1027	233	1092	267	1240	640	125	126

## Horizontal to wall mounted vertical installations (7 and 9 models only)

Vertical installations require the water pump to be rotated 90°.

1. Remove the electrical control box cover, unplug the pump and water level switch terminals from the main control board.

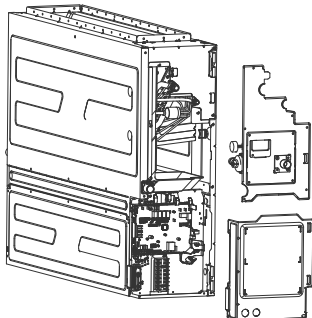

2. Disassemble the pump components.

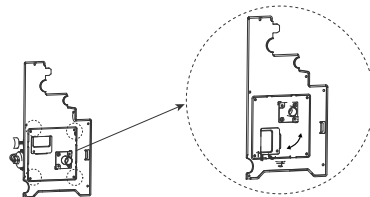

3. Remove the four screws, rotate the water components by 90° and fix them to the water heater mounting plate again.

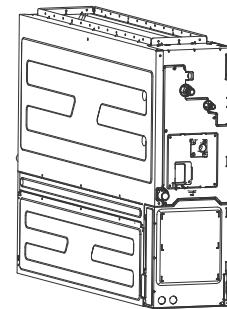

4. Reinstall the pump and reconnect to the main control board.

## Hang indoor unit: 15-18 models

Refer to the following diagrams to locate the four positioning screw bolt holes on the ceiling. Be sure to mark the places where you will drill ceiling hook holes.

### Air outlet dimensions

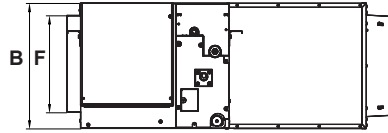
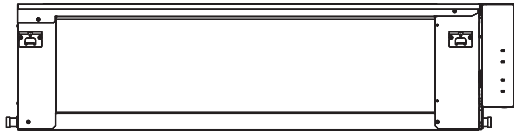

### Air inlet dimensions

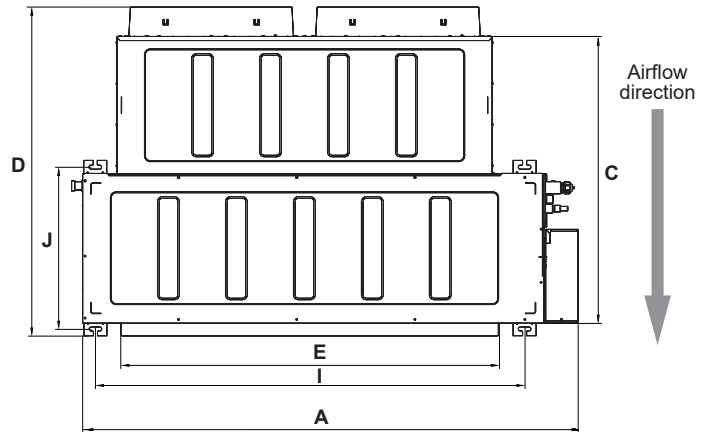
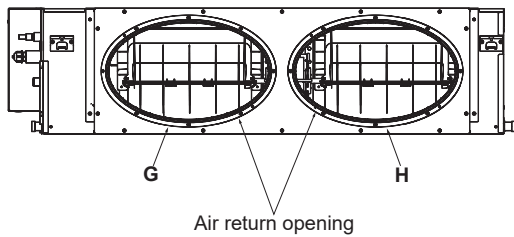

Model	Outline dimension (mm)				Air outlet opening size (mm)		Air return opening size (mm)		Dim. of moulded lug (mm)	
	A	B	C	D	E	F	G	H	I	J
15 / 18	1508	380	870	1000	1152	295	Ø400	Ø400	1307	493



NOTE

Return air pop connections supplied with the unit do not determine return air duct size.

## Separating and reassembly of the 15/18 kW splittable units

If the system is already installed and the unit needs to be separated, the power must be disconnected.

Only separate the indoor unit when necessary—disassemble and reassemble on a flat surface.

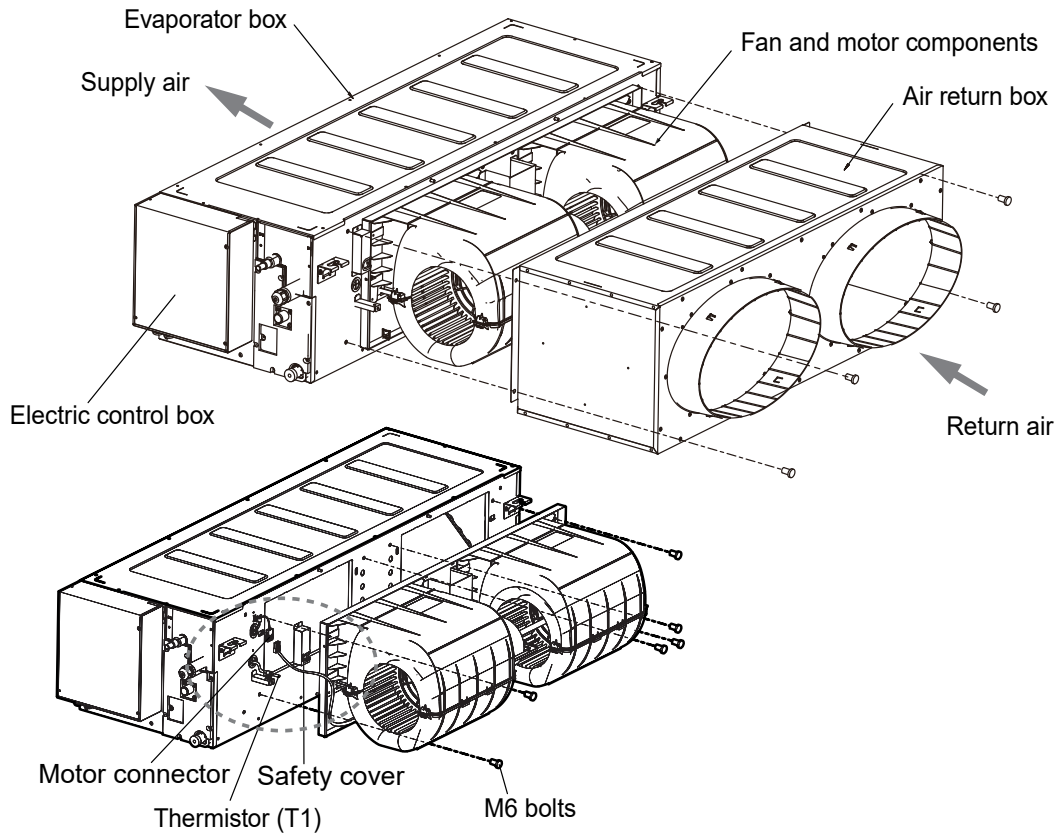

### Separate the indoor unit in the following order:

1. Carefully remove the air return box by removing the four M6 bolts.
2. Carefully remove the safety cover by removing the two screws.
3. Carefully disconnect the fan motor wiring.
4. Remove six M6 bolts securing the fan and motor assembly on the evaporator box.
5. Carefully separate the fan and motor assembly from the evaporator box, taking care not to damage the fan motor wiring.

### Reassemble the indoor unit in the following order:

6. Carefully connect the fan and motor assembly to the evaporator box with six M6 bolt
7. Reconnect the fan motor connector back to the connector of evaporator box.
8. Carefully fix the safety cover with two screws, taking care not to damage the connector and wiring.
9. Carefully fix the return air box to the evaporator box with four M6 bolts.



Check the fan motor connector is connected properly before use.

# Indoor unit installation - hanging bolts

## Installing Ø10 hanging bolts (four bolts)

Check the ceiling type and isolate roof mountings from possible vibration.

When choosing where to locate the unit, consider the position of the refrigerant pipe and drains (confirming a minimum drain fall of 1:50). Make sure that the refrigerant pipe, drain pipes, indoor, and outdoor wiring can be routed and positioned adequately before hanging the unit. Once the unit is installed, fit off the refrigerant and connections.

Installation of the hanging screw bolts

- Strengthen roof beams as required to support full operating weight of the unit.
- Securely mount the hanging screw bolts, and inspect for tightness. It is recommended that the indoor unit be installed with an incline towards the condensate drain of at least 10-20 mm to assist proper drainage.

## Hanging the indoor unit

Hang the indoor unit as shown below.

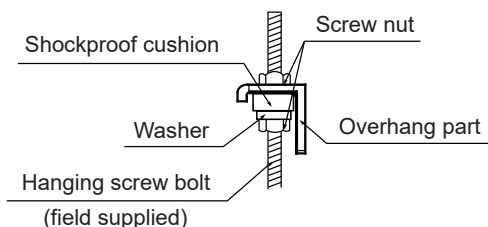

- Do not place the connecting duct weight on the indoor unit.
- Use compliant R rated duct for the area of installation.
- When connecting the duct, allow for removal and maintenance.
- Change the fan motor static pressure corresponding to external duct static pressure.

## Air inlet direction: 7-13 models only

Adjust the air inlet direction from the rear side to under side.

1. Take off the ventilation panel and return air flange (see below).
2. Fit return air flange to the unit's base.
3. Fit ventilation panel to the unit's rear.

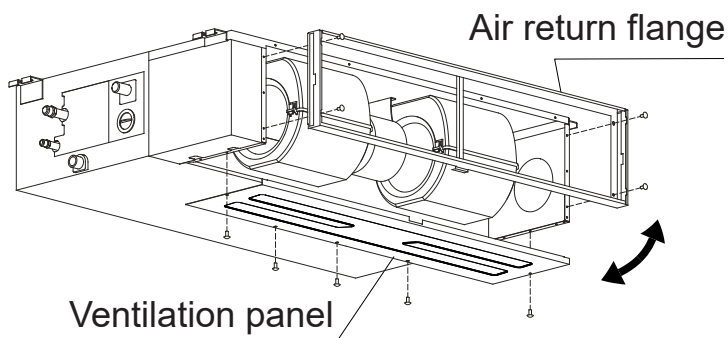

# Indoor unit installation - drainpipe

The condensate drain terminal point must comply with AS/NZS 3500 Plumbing and Drainage.

- Insulate all piping to prevent condensation, which could lead to water damage.
- If the drainpipe is bent or installed incorrectly, water may leak and cause a water-level switch malfunction.
- In 'Heat' mode, the outdoor unit will discharge water—ensure that the drain hose is placed in an appropriate area to avoid water damage and slippage.
- DO NOT pull the drain pipe forcefully, this could disconnect it.
- When using an extended drainpipe, tighten the indoor connection with an additional protection tube, this prevents it from pulling loose.

## Indoor drainpipe installation

The primary condensate drain from all indoor models is supplied configured for pump operation.

1. Cover the drainpipe with heat insulation to prevent condensation and leakage.
2. Attach the mouth of the drain hose to the unit's outlet pipe. Sheath the mouth of the hose and clip it firmly with a pipe clasp.

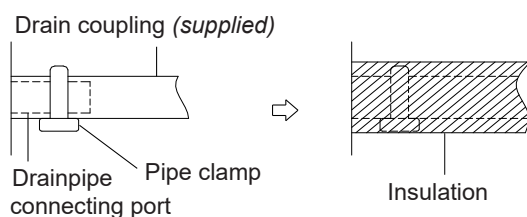

### Pumped Condensate Drain

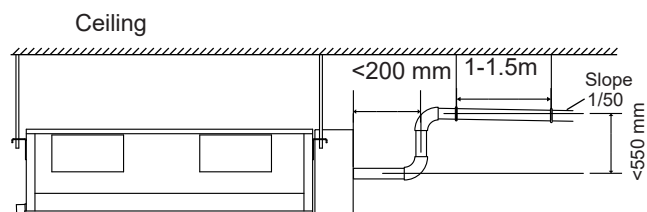

- The drainpipe should slope downward at a gradient of at least 1/50 to prevent water from flowing back into the unit.
- To prevent the pipe from sagging, place supports every 1-1.5 m.
- If the outlet of the drainpipe is higher than the body's pump joint, use a lift pipe for the indoor's unit exhaust outlet. The lift pipe must be installed no higher than 550 mm from the ceiling board. The distance between the unit and the lift pipe must be less than 200 mm. Incorrect installation could cause water to flow back into the unit and flood.
- To prevent air bubbles, keep the drain hose level or slightly tiled up (<75 mm).

## Factory configured for pump operation - all models

All units are equipped with an inbuilt pump and are factory configured for pump operation electrically via the PCB (CN13 - power and CN5 - water level sensor).

7 - 13 models

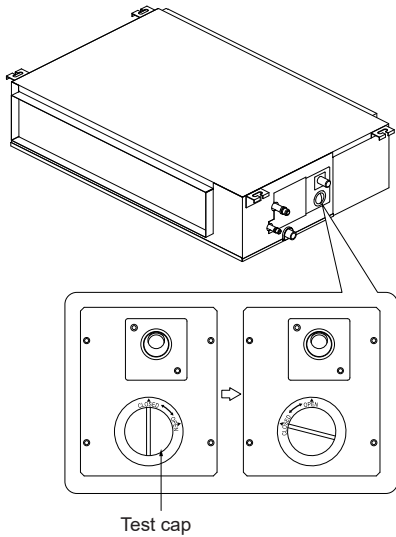

15 - 18 models

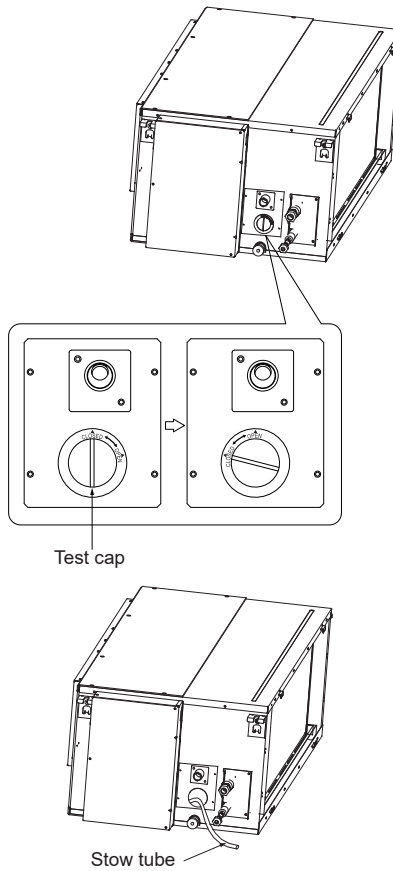

1. Remove the test cover, then fill the water pan with two litres of water.
2. During commissioning or test run stage, turn on the unit in 'Cooling' mode, you will hear the drain pump start. Check whether the water is discharging properly (a one minute lag is possible, depending on the length of the drain pipe). Check for water leaks from all joints. To force the system into 'Cooling' mode, refer to section 'Forced Cooling' on p.31
3. Turn off the unit and put the cap back on.

## Gravity condensate drain

To configure the primary condensate drain for gravity feed, do the following:

- Isolate the power to the indoor unit.
- Remove bung from gravity drain spigot and insert into the pump drain spigot.
- Access the indoor unit PCB by removing the cover and disconnecting CN13.
- Disconnect the water level sensor at CN5.
- With the CN5 bypass connector supplied in the accessory pack connect to the CN5 to create a short circuit.
- Replace the indoor unit PCB cover and return power to the indoor unit.

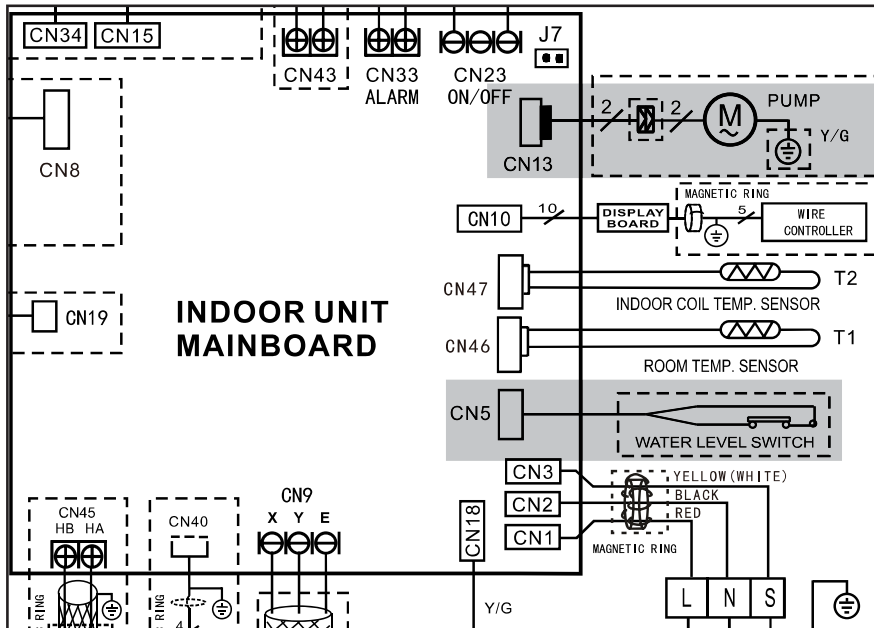

The trap needs to be installed as close to the unit as possible. Make sure the top of the trap is below the connection to the drain pan to allow complete drainage of the pan.

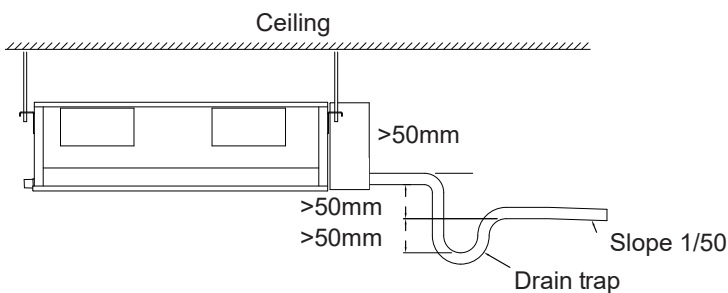

Before installing ductwork, check whether the drainpipe is unhindered. This test should be performed on newly built houses before the ceiling is installed.

7 - 13 models

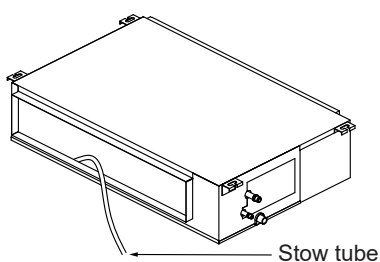

15 - 18 models

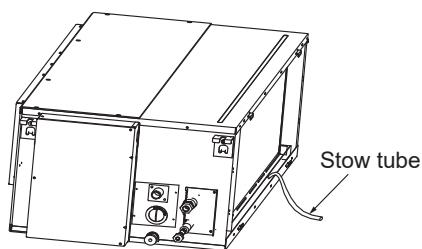

Fill the water pan with two litres of water. Check that the drainpipe is unhindered.

# Outdoor unit installation - location

## Clearances

The outdoor unit must be installed in accordance with the clearances outlined below. Note maintenance access, there must be sufficient room for installation and maintenance.

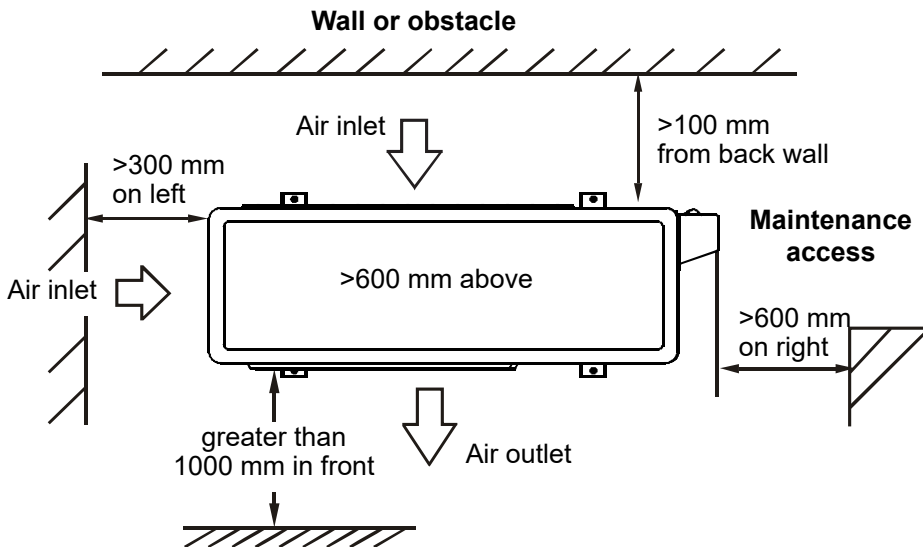

## Installation position

The outdoor unit must be located in a dry and well ventilated outdoor space on a supporting structure that is flat, horizontal, and can withstand the full operating weight of the unit. The base must be free of vibration.

Locate the outdoor unit as close as possible to the indoor unit to reduce performance losses. The refrigerant pipe length or height, or height difference between outdoor and indoor does not exceed the maximum allowable limits, refer p.18.

Select a location where the unit will not be subject to accumulation of snow, leaves or other seasonal debris. This may negatively impact the performance and longevity of the unit. Arrange so the air outlet is not blocked or obstructed.

In addition:

- Position so as to prevent operating noise being a nuisance to others
- Away from potential fire risks or flammable materials
- If possible, away from exposure to direct sunlight as this will negatively impact cooling performance

DO NOT install in the following locations:

- Near an obstacle that will block air inlets and outlets
- Near a public street, crowded areas, or where noise will disturb others
- Near animals or plants that will be harmed by hot air discharge
- Near any source of combustible gas
- In a location that is exposed to large amounts of dust
- In a location exposed to excessive amounts of salty air

In severe environments (geothermal areas or areas with caustic gases) take precautions such as applying additional corrosion protection to exposed components.

### Special considerations for heavy wind exposure

For installations prone or exposed to strong prevailing winds such as coastal areas, please ensure the unit is sited appropriately by placing it lengthwise along the wall to reduce any negative impact on the condenser fans.

Install the unit so that the air outlet fan is at a 90° angle to the direction of the wind. If needed build a barrier in front of the unit to protect it from extremely heavy winds.

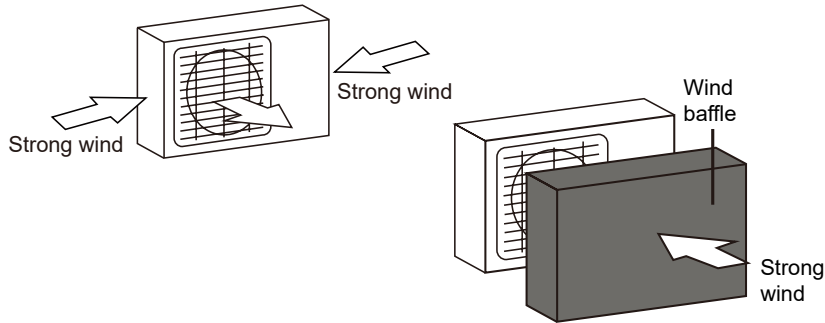

### In cold climates

In cold climates, make sure that the drain hose is as vertical as possible to ensure swift water drainage. If water drains too slowly, it can freeze in the hose and flood the unit. Insulating the drain hose in cold climates is recommended.

### Anchoring the outdoor unit

The outdoor unit can be anchored to the ground or to a wall mounted bracket with bolts (M10), or equivalent. Prepare the installation base of the unit according to the dimensions on the following page.

To reduce the transmission of vibration and noise, waffle pads shall be installed beneath the unit at each anchor point.

### Drain joint

Before bolting the outdoor unit in place, install the drain joint at the bottom of the unit. There are two different types of drain joints depending on the type of outdoor unit.

The drain joint comes with a rubber seal.

- Fit the rubber seal on the end of the drain joint that will connect to the outdoor unit.
- Insert the drain joint into the hole in the base pan of the unit.
- Rotate the drain joint 90° until it clicks in place facing the front of the unit.
- Connect a drain hose extension (not included) to the drain joint to redirect water from the unit during heating mode.

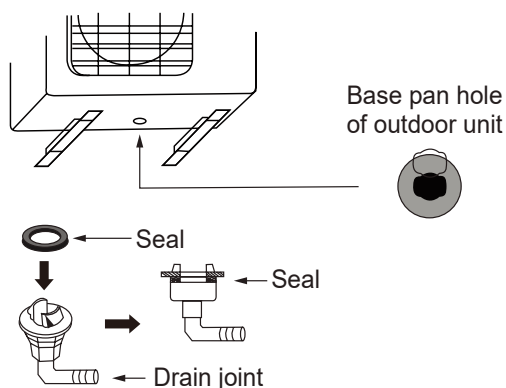

# Outdoor unit installation - mounting dimensions

Prepare the installation base of the unit according to the dimensions below.

Model	Outdoor unit W x D x H	Mounting dimensions	
		Distance A	Distance B
7	890 x 342 x 673 mm	663 mm	354 mm
9 / 11	946 x 410 x 810 mm	673 mm	403 mm
13 / 15	980 x 415 x 975 mm	616 mm	397 mm
15 / 18 splittable	952 x 415 x 1333 mm	634 mm	404 mm

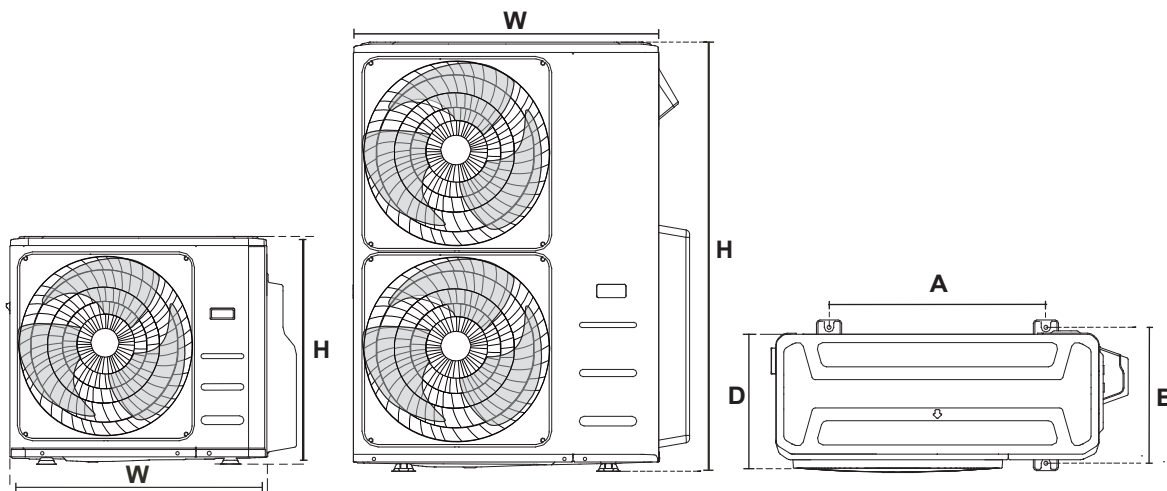

## Multiple units

	L	A
$L \leq H$	$L \leq \frac{1}{2} H$	25 cm or more
$L > H$	$\frac{1}{2} H < L \leq H$	30 cm or more
	Cannot be installed	

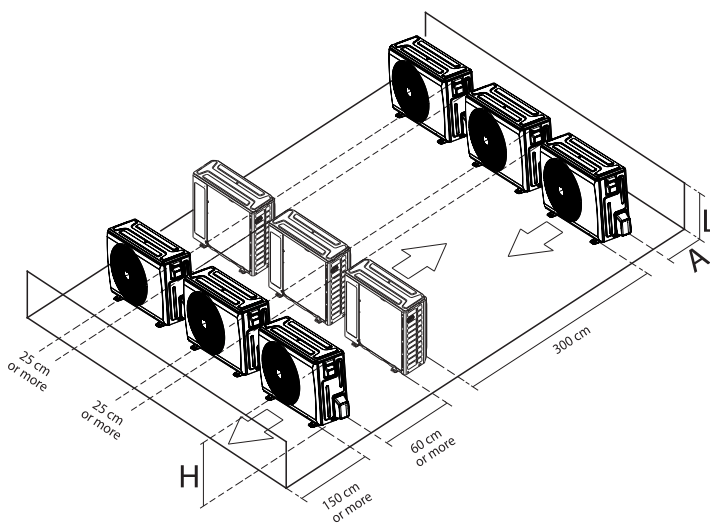

# Refrigerant piping connection

When connecting refrigerant piping do not let substances or gases other than the specified refrigerant enter the unit. The presence of other gases or substances will lower the unit's capacity, and can cause abnormally high pressure in the refrigeration cycle. This can cause explosion and injury.

The branching pipe must be installed horizontally. An angle of more than 10° may cause malfunction. Insulate the gas and liquid piping to prevent condensation.

DO NOT install the connecting pipe until both the indoor and outdoor units have been installed.

## Pipe length

Ensure the length of the refrigerant pipe, the number of bends, and the drop height between the indoor and outdoor units meets the requirements shown below.

Maximum length and drop height		
Model	Maximum equivalent pipe length	Maximum vertical separation
7	50 m	25 m
9 / 11 / 13	75 m	30 m
15 / 18		

## Oil traps

If oil flows back into the unit's compressor this might cause liquid compression or deterioration of oil return. Oil traps in the rising gas piping can prevent this. For units less than 10.5 kW, an oil trap should be installed every 6 m of vertical suction line riser. For units greater than or equal to 10.5 kW, an oil trap should be installed every 10 m of vertical suction line riser.

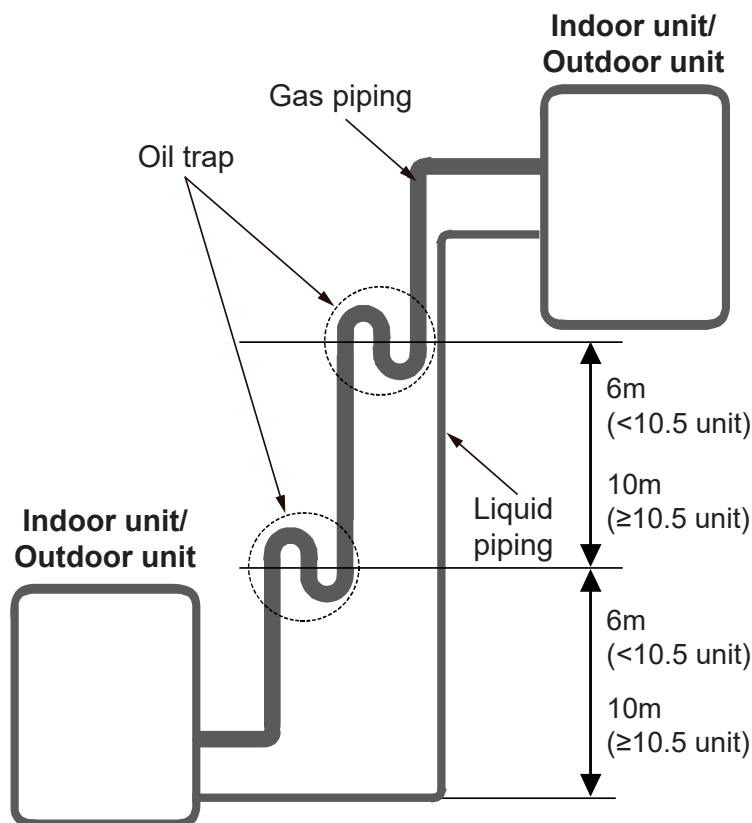



Avoid direct contact with bare pipes as this may result in burns or frostbite.

### Step 1: Cut pipes

Proper flaring is essential to achieve an airtight seal. Use the correct R32 flaring tool.

When preparing refrigerant pipes, take extra care to cut and flare them properly. This will ensure efficient operation and minimise the need for future maintenance. Be careful not to damage, dent, or deform the pipe while cutting. This will drastically reduce the heating efficiency of the unit.

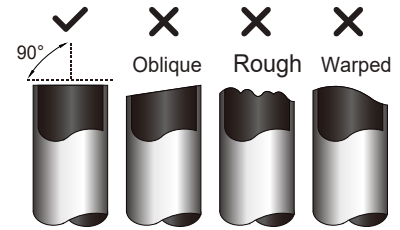

- Measure the distance between the indoor and outdoor units.
- Using a pipe cutter, cut the pipe a little longer than the measured distance.
- Make sure that the pipe is cut perfectly at a 90° angle.

### Step 2: Remove burrs

Burrs affect the airtight seal of the refrigerant piping connection. They must be completely removed. Hold the pipe at a downward angle to prevent burrs from falling into the pipe. Using a reamer or deburring tool, remove all burrs from the cut section of the pipe.

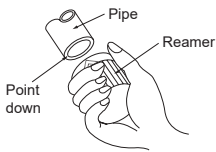

### Step 3: Flare pipe ends

Proper flaring is essential to achieve an airtight seal. After removing burrs from the cut pipe, seal the ends with PVC tape to prevent foreign materials from entering the pipe. Sheath the pipe with insulating material.

Place the flare nuts on both ends of the pipe. Make sure they are facing in the right direction, as you can't put them on or change direction after flaring.

Remove PVC tape from the ends of the pipe when ready to perform flaring work. Clamp flare form on the end of the pipe. The end of the pipe must extend beyond the flare form.

Place flaring tool onto the form. Turn the handle of the flaring tool clockwise until the pipe is fully flared. Flare pipe in accordance with the dimensions below then remove the flaring tool and flare form, then inspect the end of the pipe for cracks and even flaring.

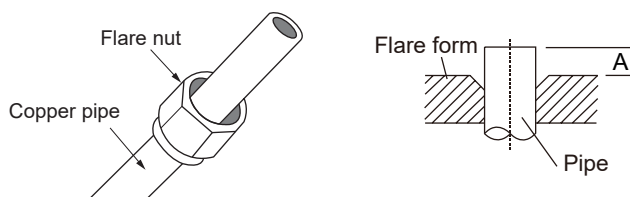

### Piping extension beyond flare form

Pipe gauge	Flare nut outer	Tightening torque	Flared dimensions (A)		Flare shape
			Min.	Max.	
Ø 9.52 (Ø <sup>3</sup> / <sub>8</sub> ")	22 mm	33-42 N.m	13.2 mm	13.5 mm	
Ø12.7 (Ø <sup>1</sup> / <sub>2</sub> ")	24 mm	50-62 N.m	16.2 mm	16.5 mm	
Ø16 (Ø <sup>5</sup> / <sub>8</sub> ")	27 mm	63-77 N.m	19.2 mm	19.7 mm	
Ø19 (Ø <sup>3</sup> / <sub>4</sub> ")	-	90-110 N.m	23.2 mm	23.7 mm	

#### Step 4: Connect pipes

Connect the copper pipes to the indoor unit first, then connect to the outdoor unit. Connect the low pressure pipe, then the high pressure pipe.

When connecting the flare nuts, apply a thin coat of compatible refrigeration oil to the flared ends of the pipes. Align the centre of the two pipes that will be connected. Tighten the flare nut as tightly as possible by hand. Using a spanner, grip the nut and use a torque wrench to tighten the flare nut according to the torque values in the table on the previous page.

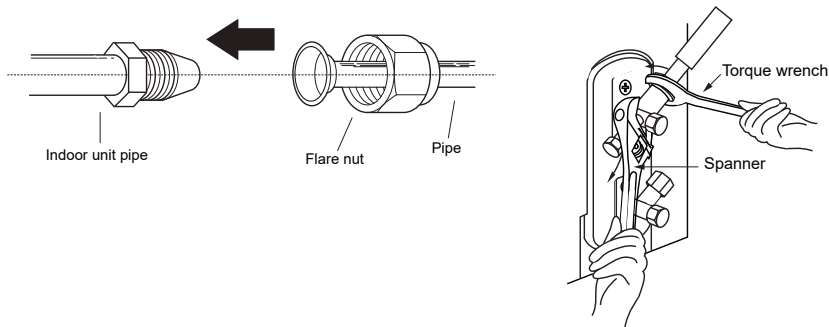

Carefully bend the tubing in the middle. DO NOT bend the tubing more than 90° or more than three times.

After connecting the copper pipes to the indoor unit, wrap the power cable, signal cable, and then the piping together with the binding signal tape. DO NOT intertwine or cross the signal cable with other wires, while bundling these items together.

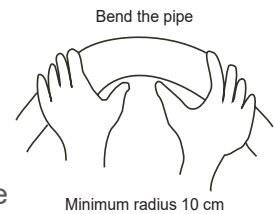

Make sure the pipe is connected correctly. Overtightening may damage the bell mouth and under tightening may lead to leakage.



#### Please note:

- Pipe run must be supported every 2 m
- R32 flammable refrigerant labels must be placed on the pipe every 2 m
- Insulate all the piping, including the valves of the outdoor unit.

# Wiring and controllers



Before performing any electrical or wiring work, turn off the mains power to the system.

- If the unit has an auxiliary electric heater, it **MUST** be installed at least 1 m away from combustible materials.
- To avoid getting an electric shock, **NEVER** touch the electrical components immediately after the power supply has been turned off. After turning off the power, always wait ten minutes or more before you touch any electrical components.
- Ensure that you **DO NOT** cross your electrical wiring with your signal wiring. This may cause distortion and interference.
- The unit **MUST** be connected to the main outlet. Normally, the power supply must have a impedance of 32 ohms.
- No other equipment should be connected to the same power circuit.
- Connect the outdoor wires before connecting the indoor wires.

## Controllers

The below controller may be configured to all the models detailed in this manual.

### Looms

Specification: 2-core shielded cable 0.5 mm sq x 18 m long The length of the controller loom may be up to a maximum of 40 m.

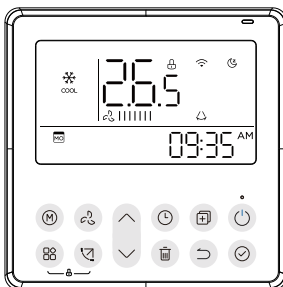

**Standard wall controller**  
CNTRLDRGINW2

# Power and communication connections

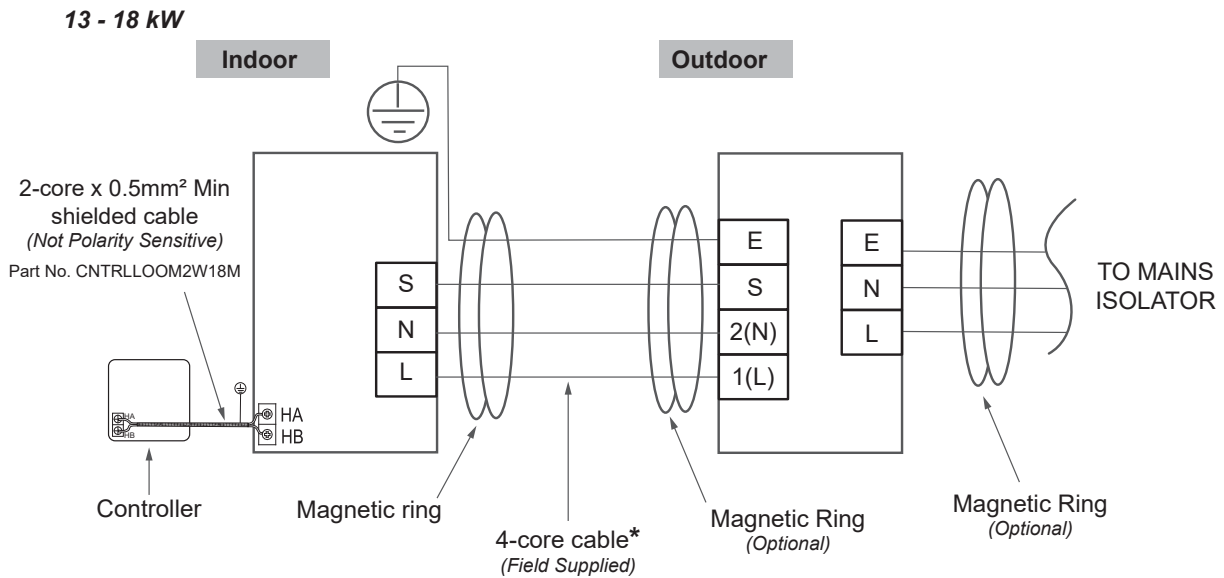
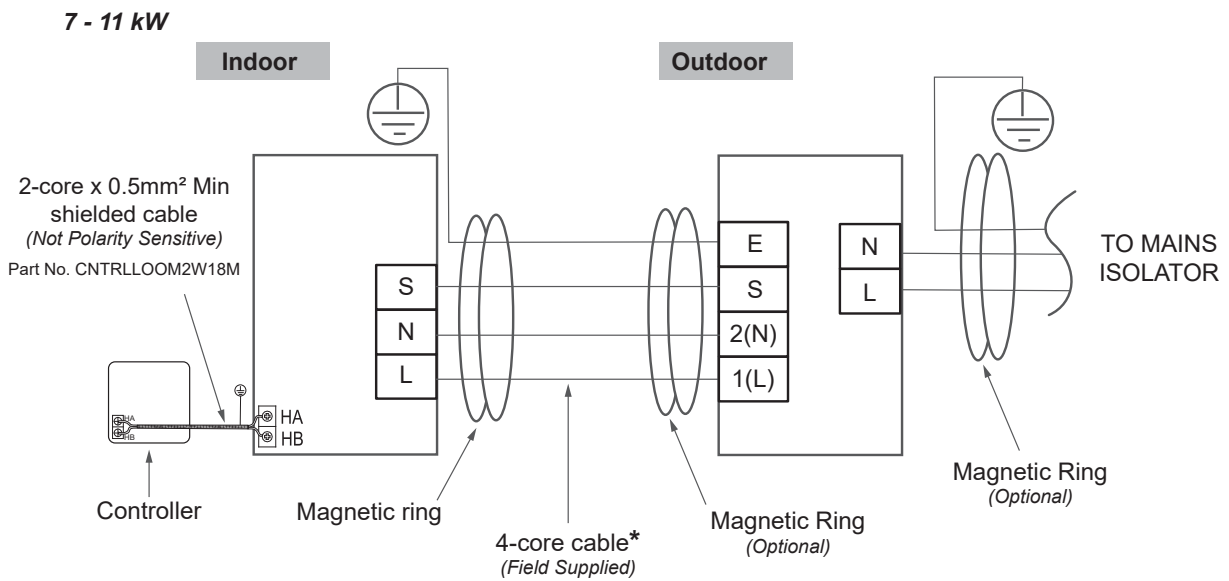

For the communication wire 'S', a single sheathed wire of 0.75 mm<sup>2</sup> may be used (field supplied).

System	7	9	11	13	15	18
Cable mm <sup>2</sup>	4 x 1.0	4 x 1.0	4 x 1.0	4 x 1.5	4 x 1.5	4 x 1.5

# Outdoor unit wiring

Prepare the cable for connection using the below table as reference. When connecting the wires, strictly follow the wiring diagram found inside the electrical box cover.

Rated current of appliance	Nominal cross-sectional area (mm <sup>2</sup> )
>3 and ≤6 A	0.75 mm <sup>2</sup>
>6 and ≤10 A	1 mm <sup>2</sup>
>10 and ≤16 A	1.5 mm <sup>2</sup>
>16 and ≤25 A	2.5 mm <sup>2</sup>
>25 and ≤32 A	4 mm <sup>2</sup>
>32 and ≤40 A	6 mm <sup>2</sup>

## Choose the right cable size

The size of the power supply cable, signal cable, fuse, and switch needed is determined by the maximum current of the unit. The maximum current is indicated on the dataplate located on the side panel of the unit. Refer to this dataplate to choose the right cable, fuse, or switch.

Using wire strippers, strip the rubber jacket from both ends of the signal cable to reveal approximately 15 cm of wire.

Strip the insulation from the ends, and using a wire crimper, crimp u-lugs on the ends.

## Connection

1. Remove the two screws fixed on the front panel and side panel, then take it down to perform the wire connection (outdoor unit A). Unscrew the electrical wiring cover and remove it (outdoor unit B).
2. Connect the u-lugs to the terminals. Match the wire colours / labels with the labels on the terminal block. Firmly screw the u-lug of each wire to its corresponding terminal.
3. Clamp down the cable with the cable clamp.
4. Insulate unused wires with electrical tape. Keep them away from any electrical or metal parts.
5. Reinstall the cover of the electrical control box.

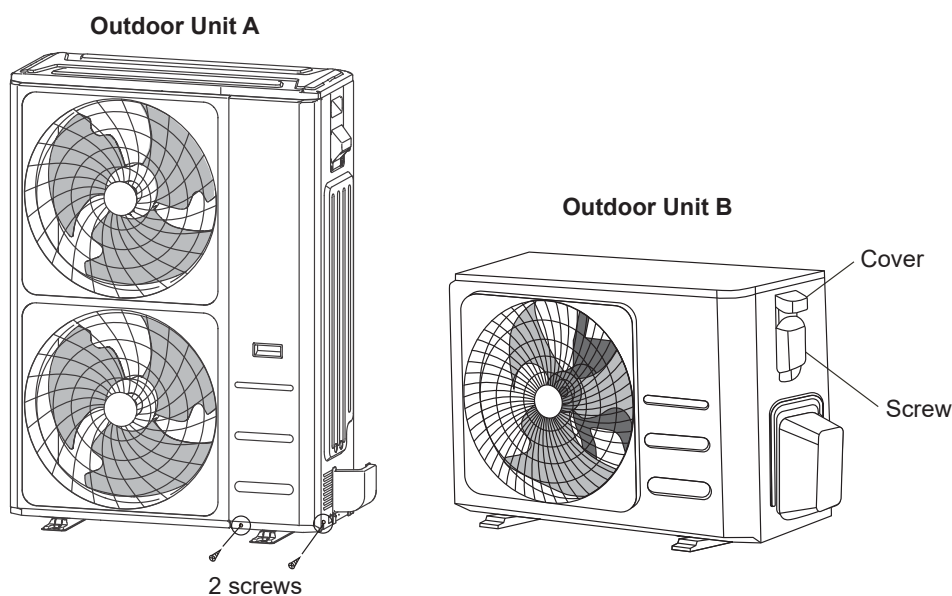

### Power and communication access to outdoor unit

1. Remove the two fixing screws as shown on previous page (outdoor unit A), and remove the front panel.
2. Remove the power and communication knock-outs with an appropriate tool.

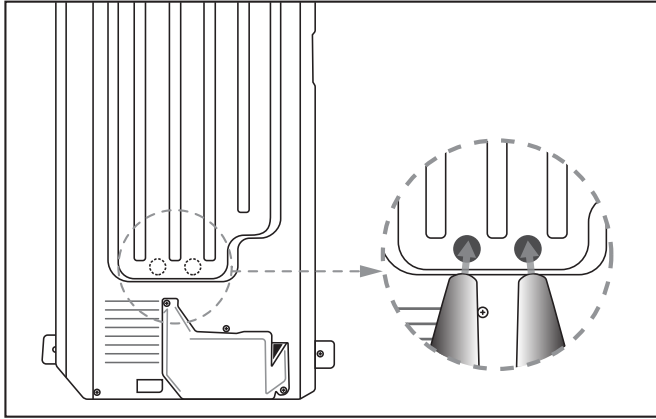

3. Feed power and communication conduits separately through the knockouts and secure cables inside of the cabinet.
4. Power and communication looms must remain secured separately inside of the cabinet.

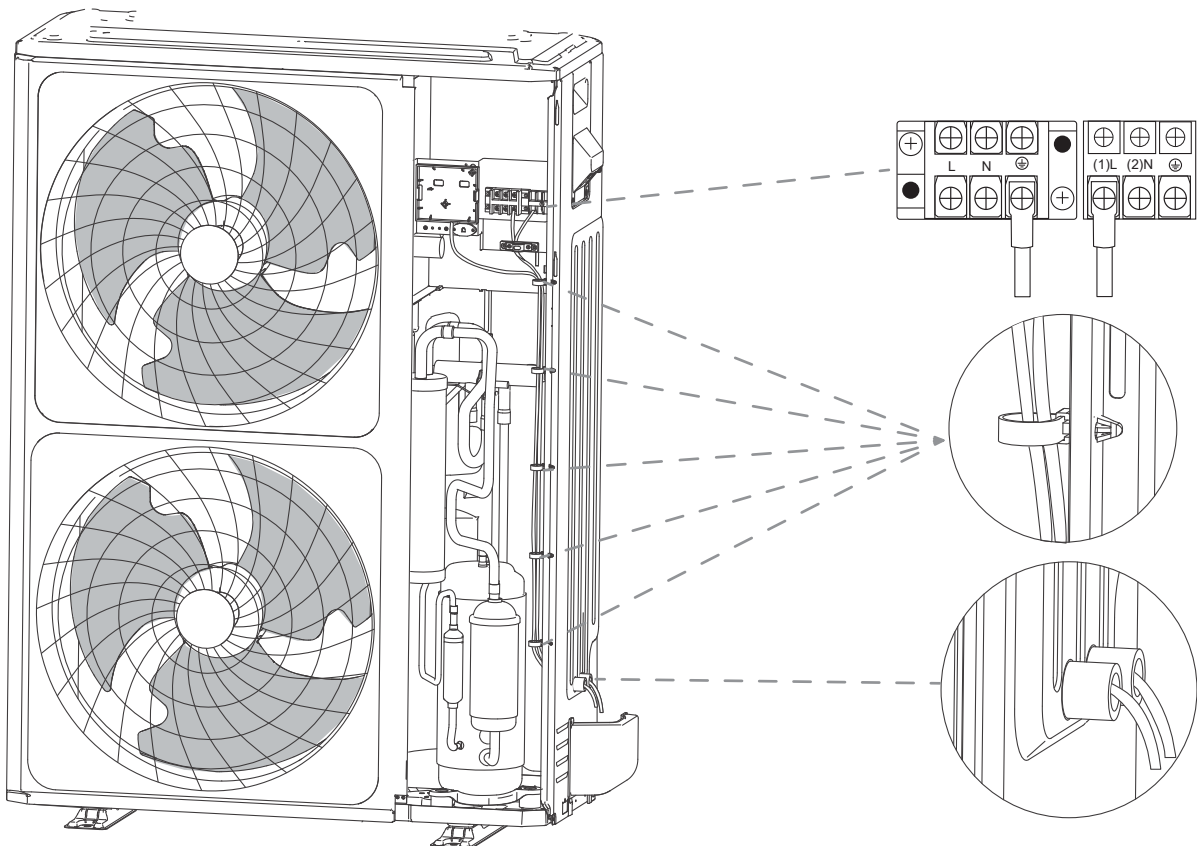

# Indoor unit wiring



The refrigerant circuit can become very hot. Keep the interconnection cable away from the copper tube.

1. Prepare the cable for connection.
  - a. Using wire strippers, strip the rubber jacket from both ends of the signal cable to reveal approximately 15 cm of wire.
  - b. Strip the insulation from the ends of the wires.
  - c. Using a wire crimper, crimp the u-lugs to the ends of the wires.
2. Remove the cover of the electrical control box on your indoor unit.
3. Connect the u-lugs to the terminals. Match the wire colours / labels with the labels on the terminal block. Firmly screw the u-lug of each wire to its corresponding terminal. Refer to the serial number and wiring diagram located on the cover of the electrical control box.
4. Clamp down the cable with the cable clamp. The cable must not be loose or pull on the u-lugs.
5. Reattach the electrical box cover.

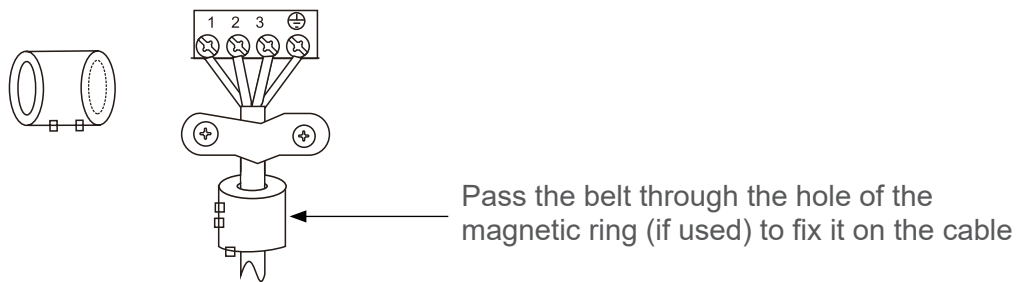
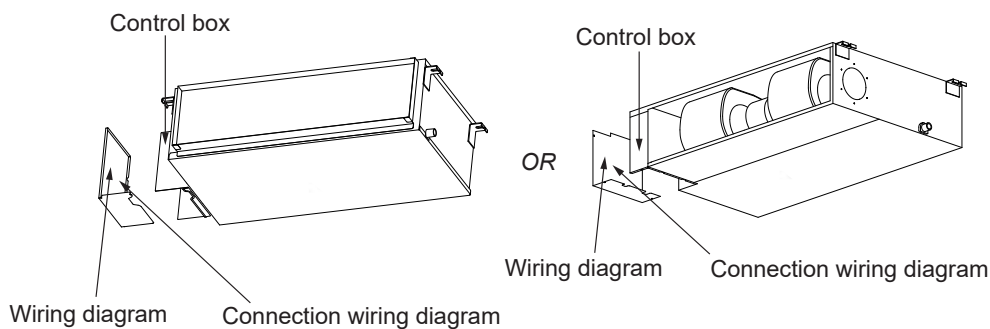

Position for connecting the display control, refer wiring diagram for connection positions. There is also a 2 m wiring loom that allows the control to be installed in a more accessible location.

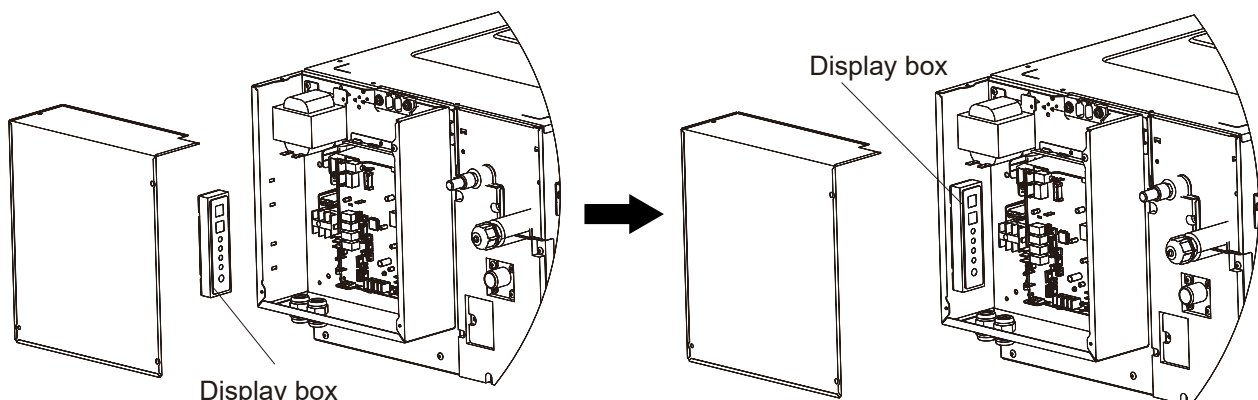

# Pressure and leak test

## Dry nitrogen pressure test

Using dry nitrogen, pressure test interconnecting pipework from the outdoor unit inclusive of the fan coil unit, to the maximum allowable pressure as indicated on the data label of the outdoor unit. For more information refer to AS/NZS 5149.2.

Air, oxygen, acetylene or refrigerants shall not be used for pressure testing purposes.



Wear the correct PPE at all time when working with refrigerants and conducting high pressure tests.

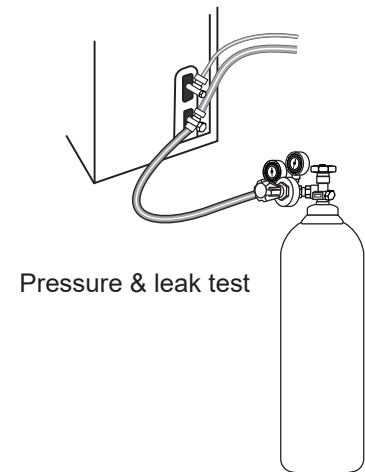

## Leak testing

1. Outdoor unit service ports shall be closed or front sealed before commencing.
2. Connect dry nitrogen bottle with gauge set to the suction line access point and ensure all fittings are tight.
3. Open the dry nitrogen bottle valves and set test pressure to the maximum allowable pressure as indicated on the outdoor unit's data label. **DO NOT EXCEED.**
4. Use an approved leak detector to assess all joints for leaks and from the outdoor service valves to the connections at the indoor unit. If no leaks are detected close the dry nitrogen valves.
5. With care, safely and slowly commence removal of the pressure supply line from the dry nitrogen bottle using the bleed to release technique.
6. Once the system pressure has been removed safely you may remove the connecting line from the service valve on the appliance

# Evacuation

Air and foreign matter in the refrigerant circuit can cause abnormal rises in pressure. This can damage the system, reduce its efficiency, and may cause injury. Use a vacuum pump and vacuum stat to evacuate the refrigerant circuit and remove any non-condensable gas and moisture from the system.

Evacuation **MUST** be performed after completion of the dry nitrogen pressure test. Before performing evacuation check to make sure:

- The connective pipes between the indoor and outdoor units are connected properly
- All wiring is connected correctly

## Evacuation

1. Vacuum the indoor interconnecting pipework to a minimum of 500  $\mu\text{m}$  of Hg.
2. Isolate the vacuum pump from the system and let the vacuum stand for one hour to ensure vacuum is maintained at 600  $\mu\text{m}$  of Hg or below. For more information, refer to 'Refrigerant handling code of practice 2007'.
3. If the system vacuum pressure decreases to a value greater than 600  $\mu\text{m}$  after one hour of standing, the pressure and leak test needs to be repeated to find the leak location.
4. If the system vacuum pressure remains below 600  $\mu\text{m}$  after one hour of standing, fasten the Schrader valve and remove all vacuum fittings.

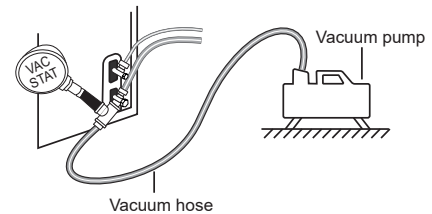

## Charging the system

1. Unscrew the cap from the packed valve (high pressure valve).
2. Insert hexagonal wrench into the packed valve and open the valve by turning the wrench anti-clockwise. Continue to turn until valve is fully back seated, and listen for the refrigerant entering the circuit.
3. Tighten the valve caps on the two valves by hand. You may tighten it further using a torque wrench if needed.

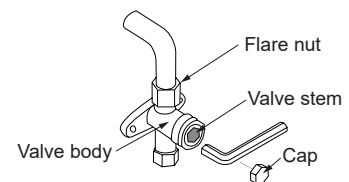
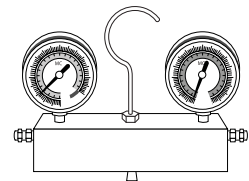

## Adding refrigerant

Some systems require additional charge depending on pipe lengths. The standard pre-charged pipe length for all models is 15 m. For pipe lengths greater than 15 m, add 24 g/m. For less than 15 m there is no requirement to remove charge.

The refrigerant must be charged from the service port on the outdoor unit's low pressure valve.



When opening the valve stems, turn the hexagonal wrench anti-clockwise until it hits against the back stop. Do not try to force the valve to open further.

Check to make sure there is no refrigerant leak after completing the installation. If there is a leak, ventilate the area immediately and evacuate the system.

Never mix refrigerant types.

# Test run

## Before the test run

The test run must be performed after the entire system has been installed. Failure to perform the test run may result in unit damage, property damage, or personal injury. Confirm the following before performing the test.

- ✓ Indoor and outdoor units are properly installed
- ✓ Piping and wiring are properly connected
- ✓ No obstacles near the inlet / outlet of the unit that might cause performance or product malfunction
- ✓ Refrigeration system does not leak
- ✓ Drainage system is unimpeded and draining to a safe location
- ✓ Insulation is properly installed
- ✓ Earthing wires are properly connected
- ✓ Length of the piping and additional refrigerant stow capacity have been recorded
- ✓ Power voltage is the correct voltage for the air conditioner

## Forced cooling

To force the system into Forced Cooling (FC), do the following:

1. At the indoor unit remove the control access panel to access the control board (shown below).
2. Press the 'Manual' button twice or until 'FC' appears in the LED display, the system will now run in the below sequence.

Compressor and outdoor fan run continuously while the indoor fan runs at low to medium speed. After thirty minutes the system will switch to auto mode with a 24 °C setting.

When the system receives a signal from the primary wall control, such as switch on, switch off, timer on, timer off, mode setting, fan speed setting, sleep mode setting or follow me setting, all forced operation sequences will cease, and control will revert to the wall control.

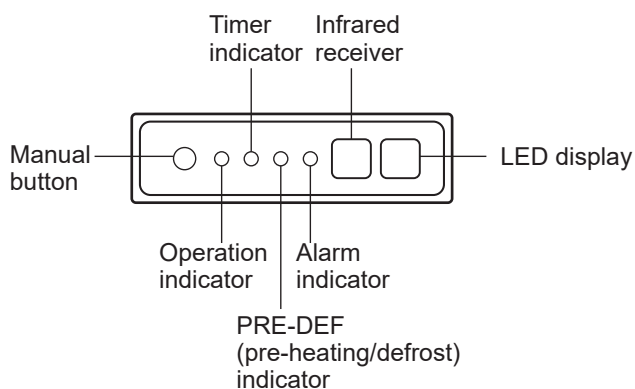

## **Test run instructions**

Set the air conditioner to COOL mode.

### For the indoor unit

- Ensure the controller buttons work properly.
- Double check to see if the room temperature is being registered correctly.
- Ensure the indicators on the controller work properly.
- Ensure the manual button on the indoor unit works properly.
- Check the drain system is unimpeded and draining properly.
- Ensure there is no vibration or abnormal noise during operation.

### For the outdoor unit

- Check for refrigerant leaks
- Ensure there is no vibration or abnormal noise during operation.
- Ensure the noise generated by the unit will not disturb neighbours or pose a safety hazard.

### Drainage test

- Ensure the drainpipe flows smoothly, for new builds perform this test before finishing the ceiling.
- Remove the test cover, add 2 L of water to the tank through the attached tube.
- Turn on the main power switch and run the air conditioner in COOL mode.
- Listen to the sound of the drain pump to see if it makes any unusual noises.
- Check to see water is discharged, it may take up to one minute.
- Make sure there are no leaks in any of the piping.
- Stop the air conditioner. Turn off the main power switch and reinstall the test cover.

# Fan performance charts

## 7.0kW FAN CURVES

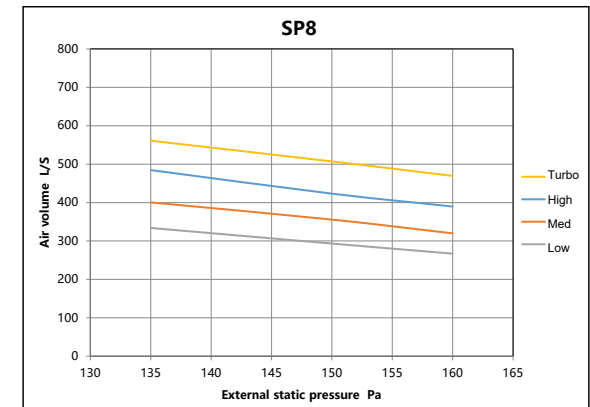
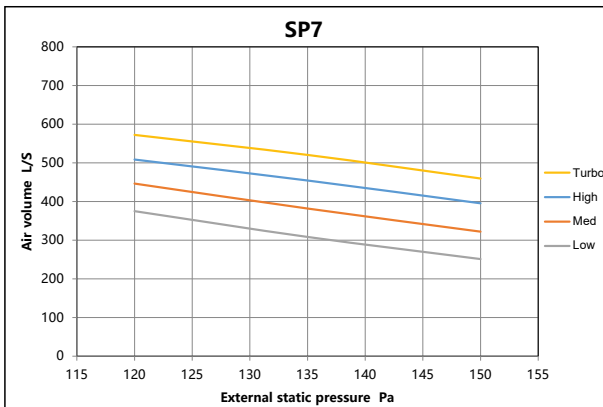
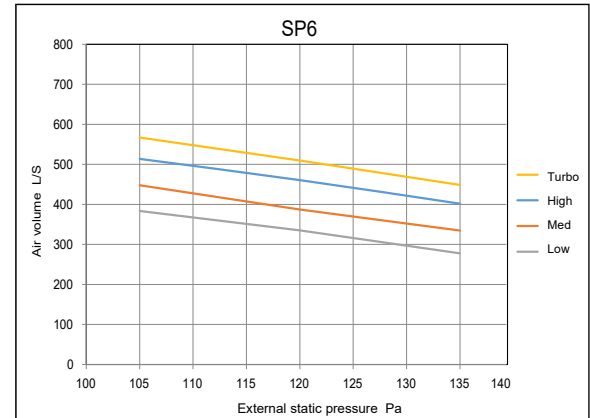
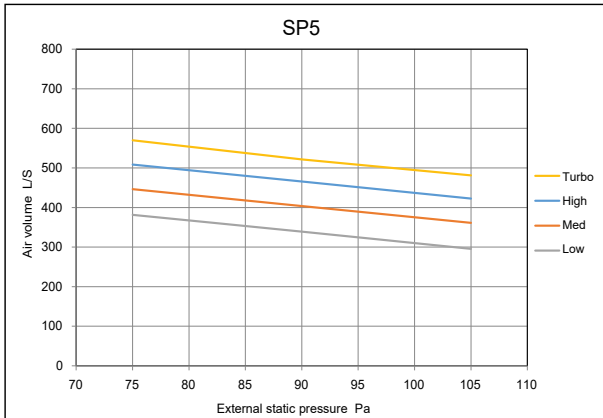
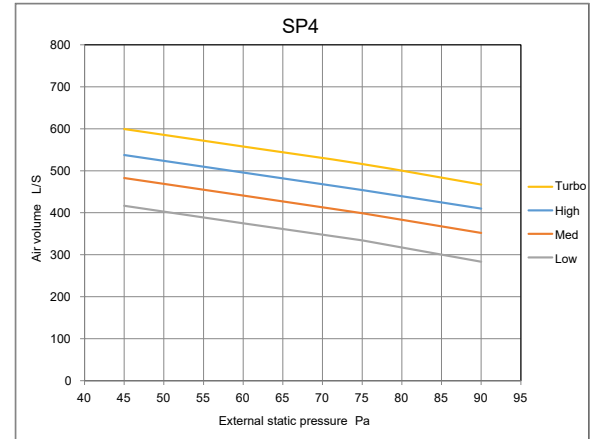
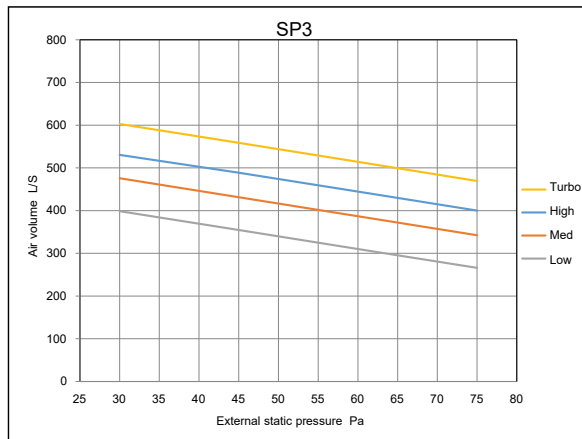
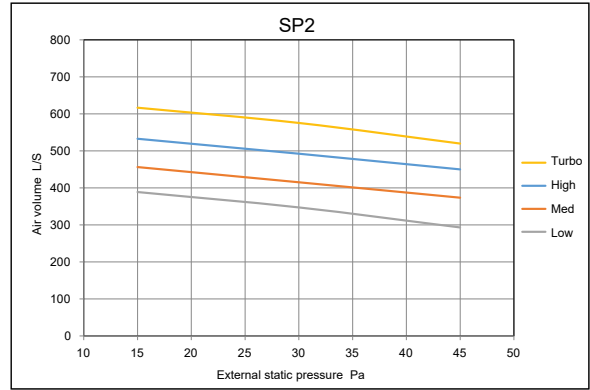
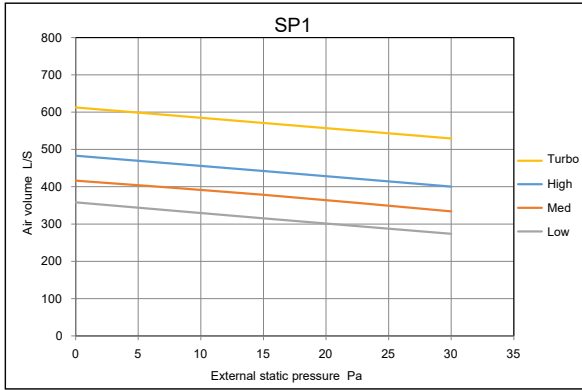

# 9.0kW FAN CURVES

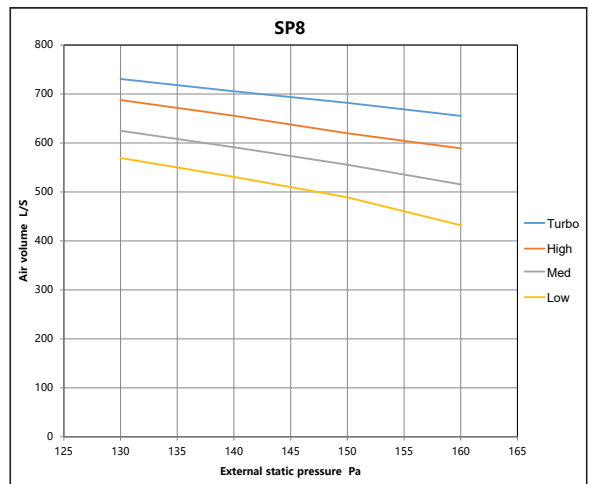
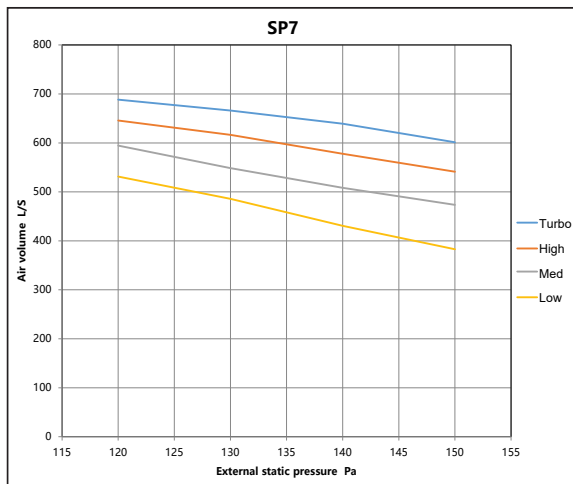
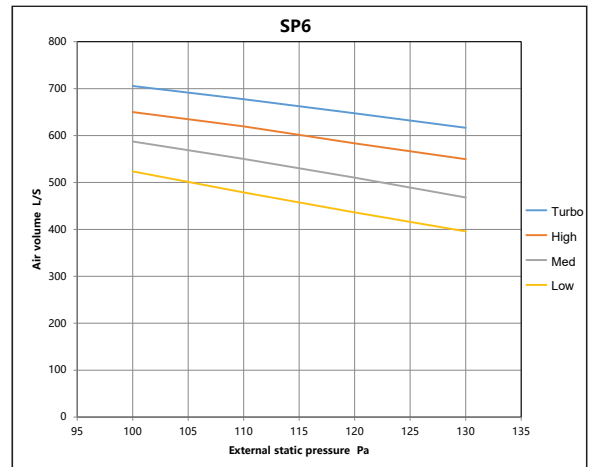
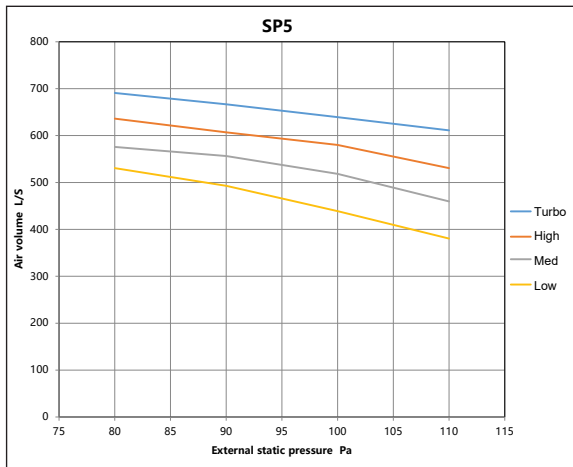
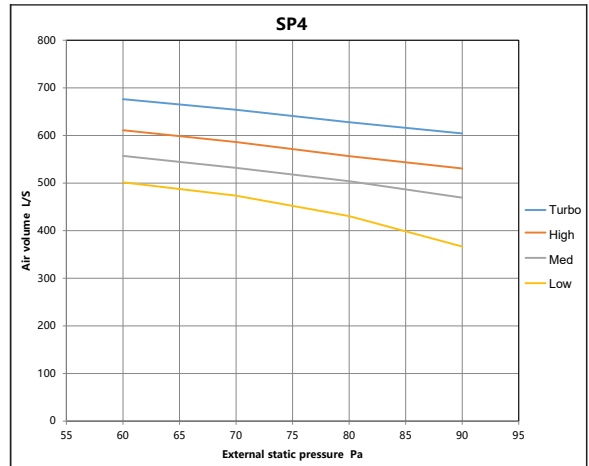
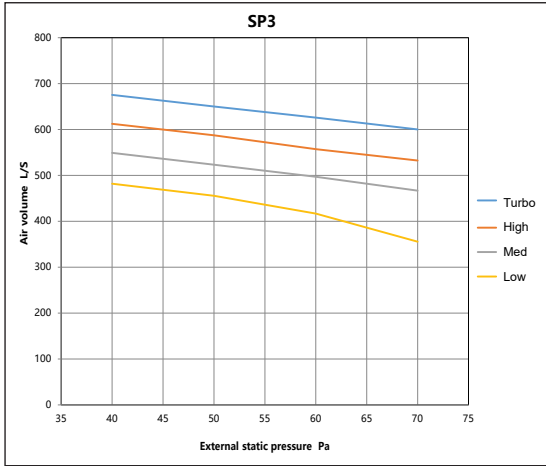
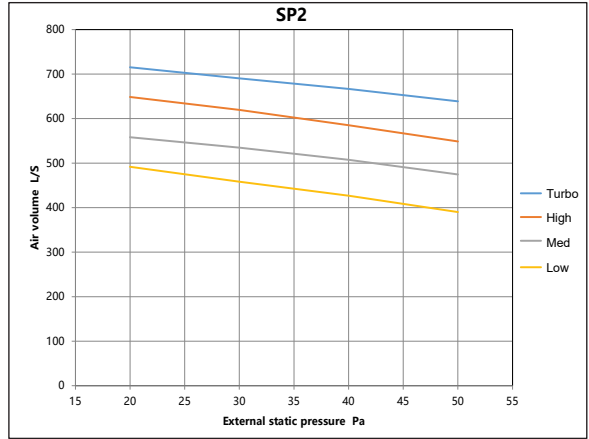
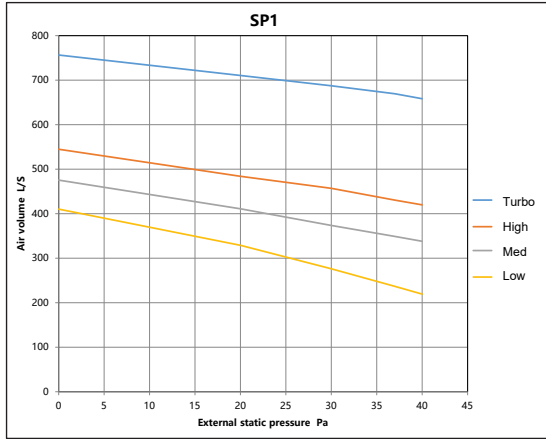

# 11.0kW FAN CURVES

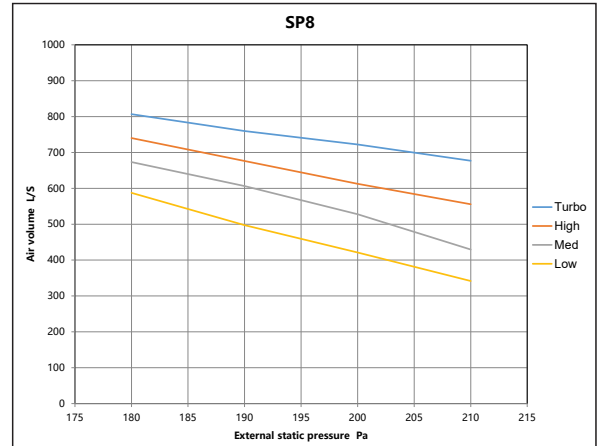
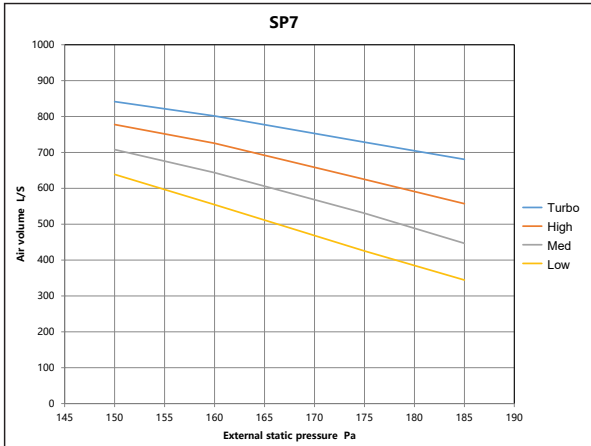
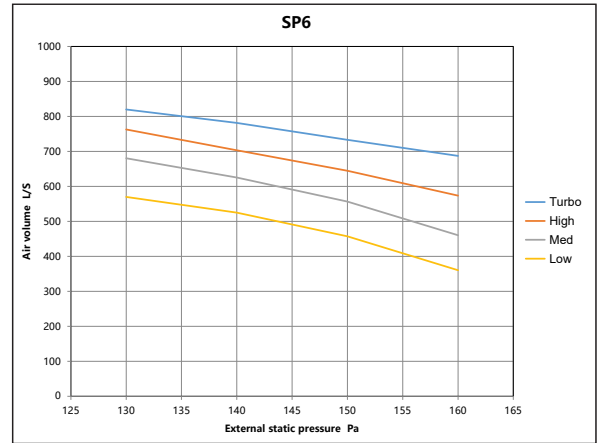
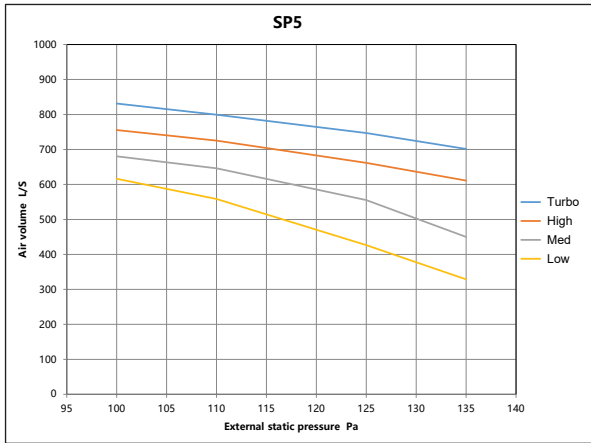
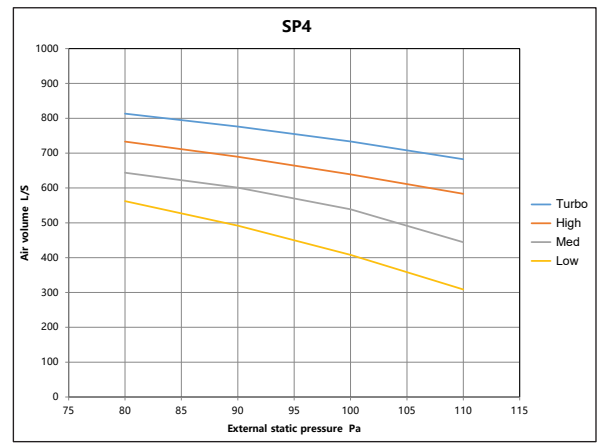
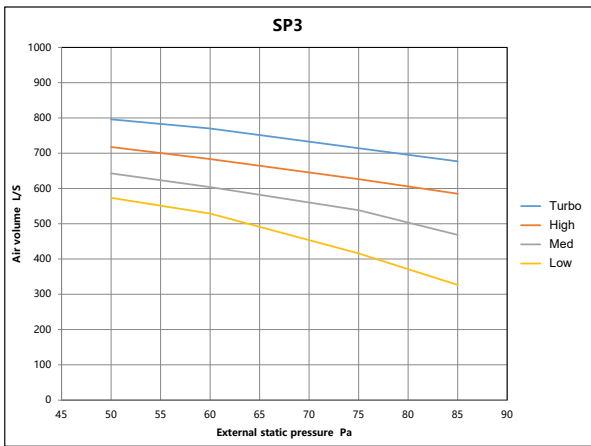
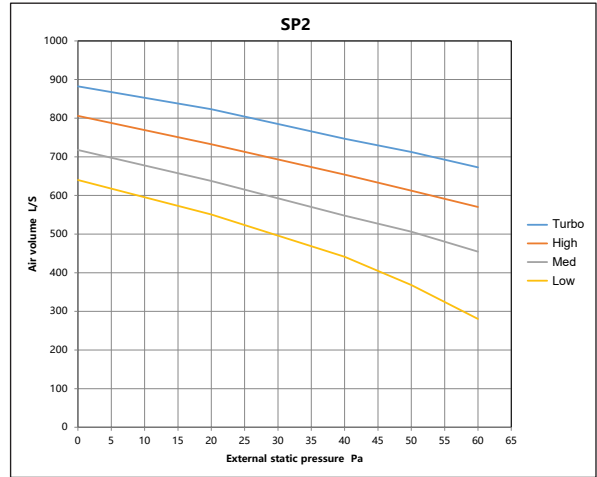
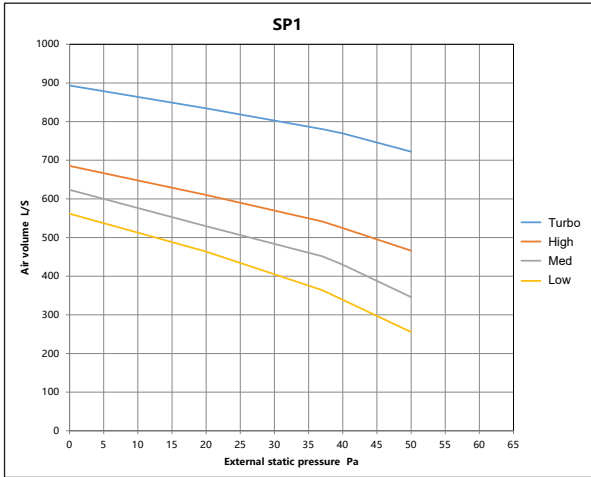

# 13.0kW FAN CURVES

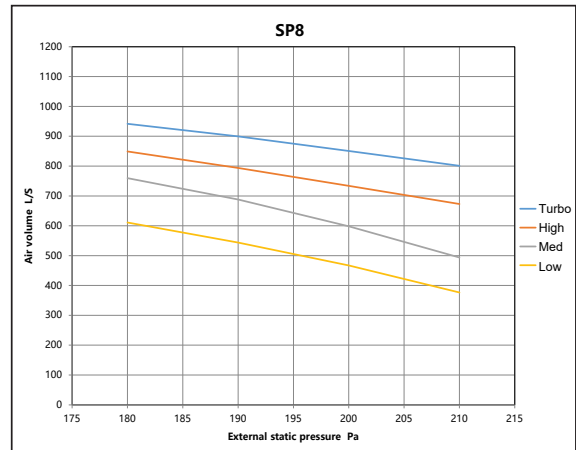
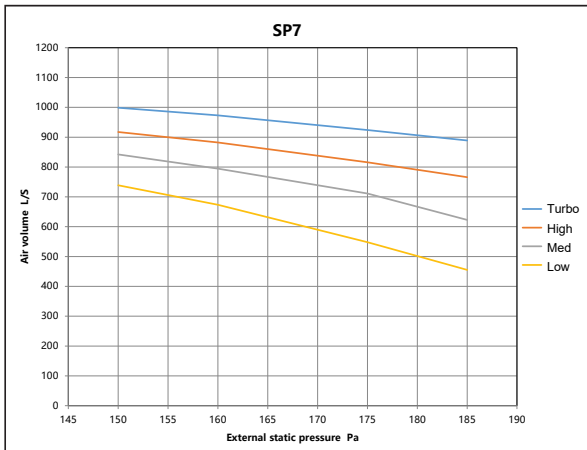
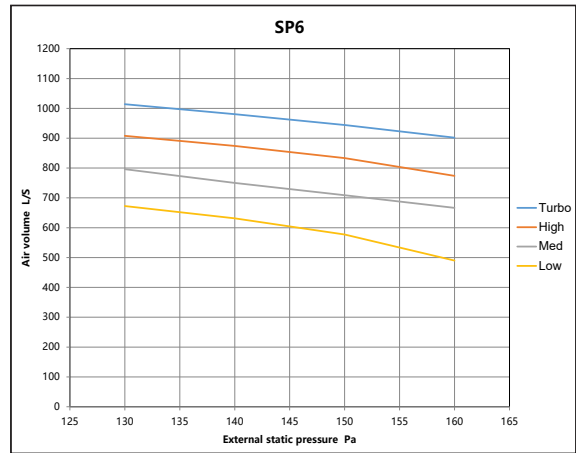
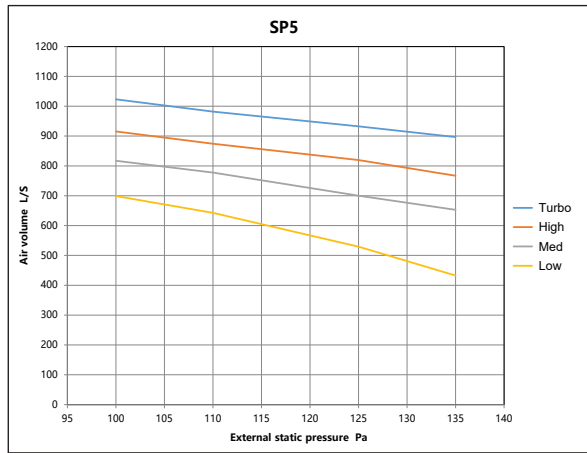
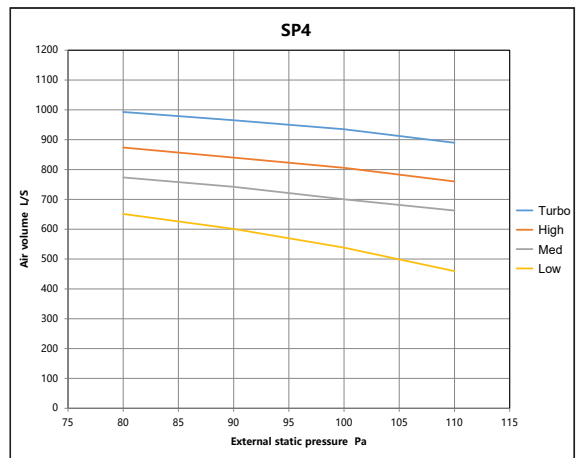
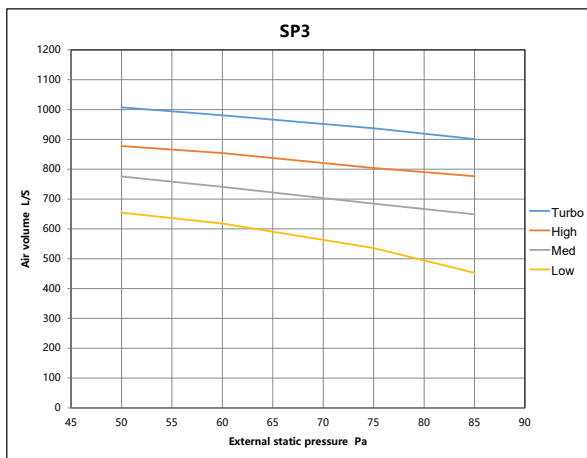
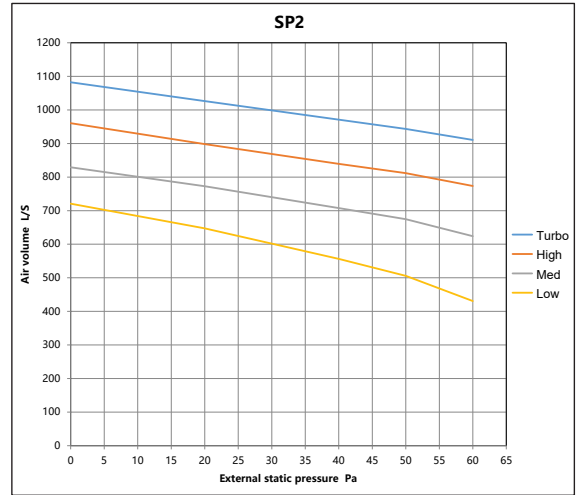
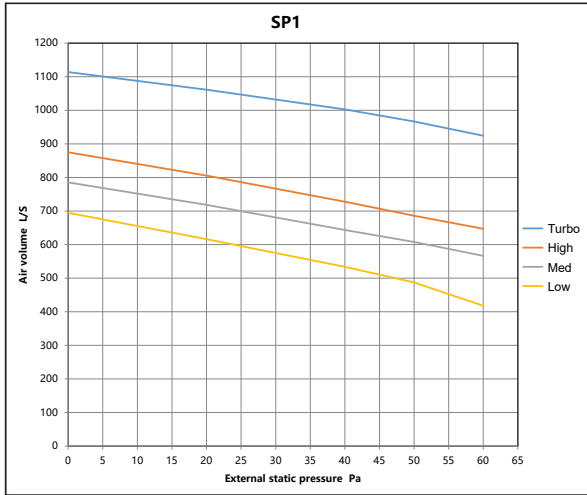

# 15.0KW FAN CURVES

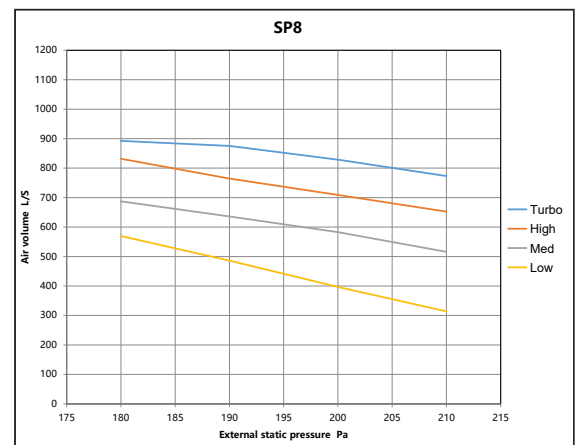
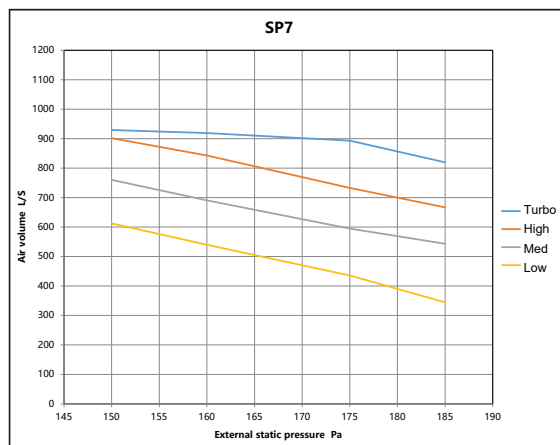
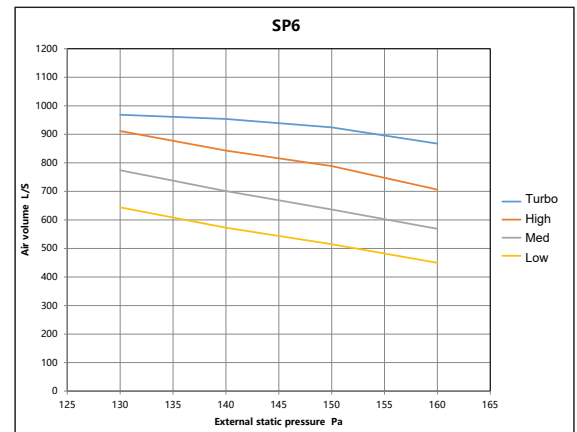
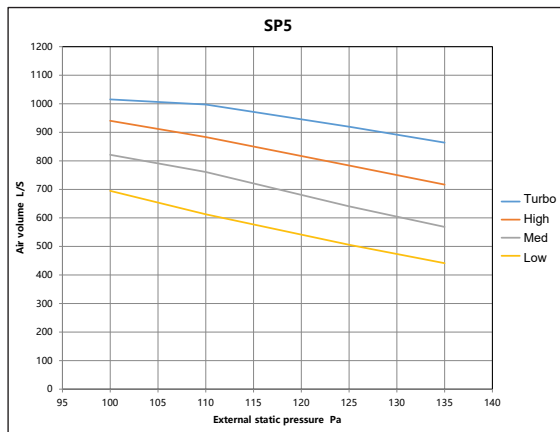
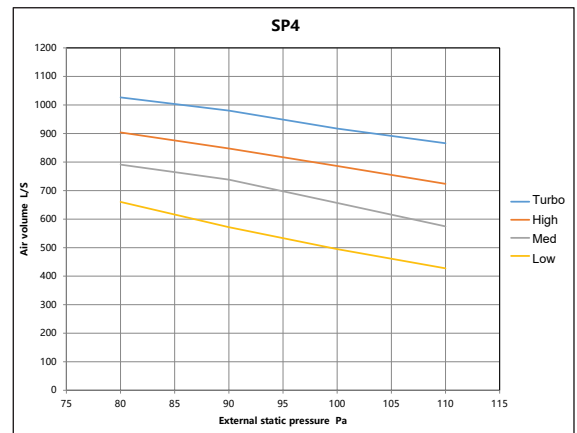
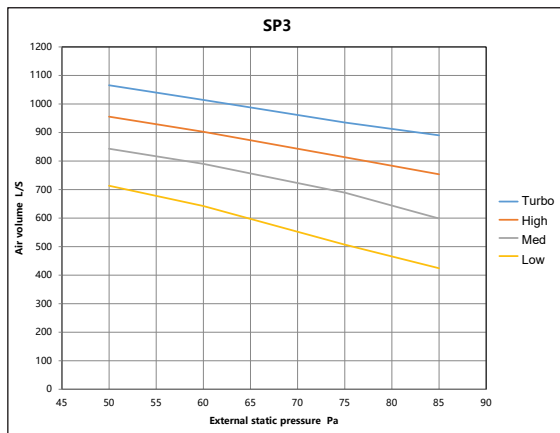
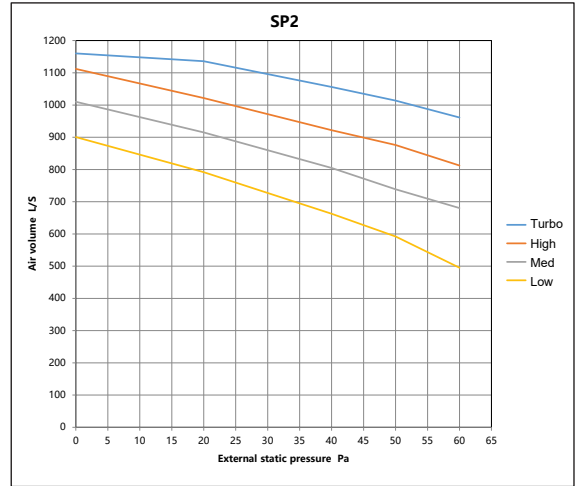
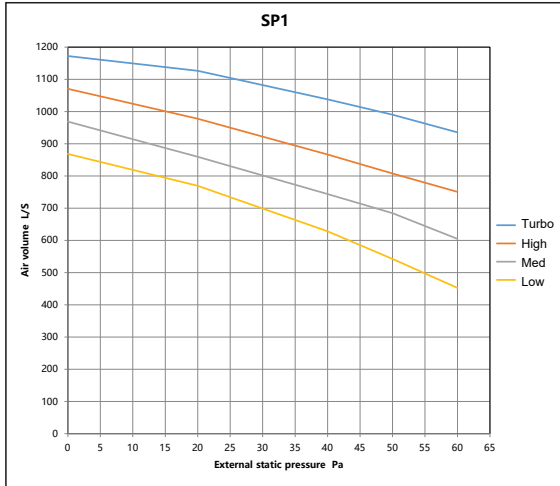

# 18.0kW FAN CURVES

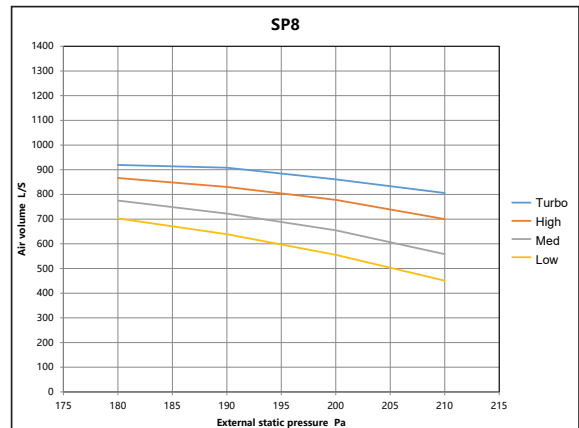
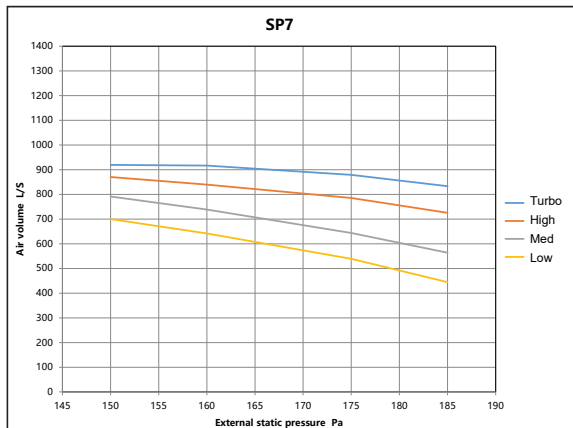
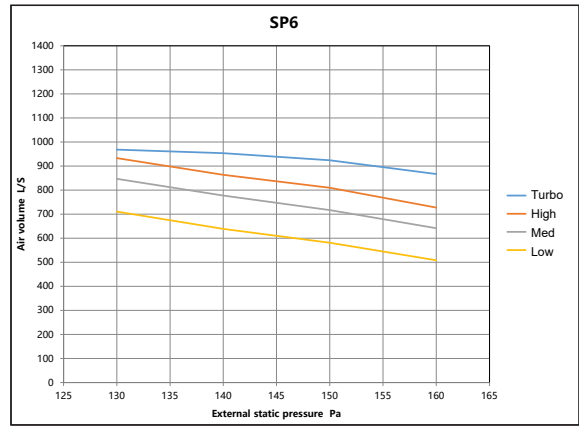
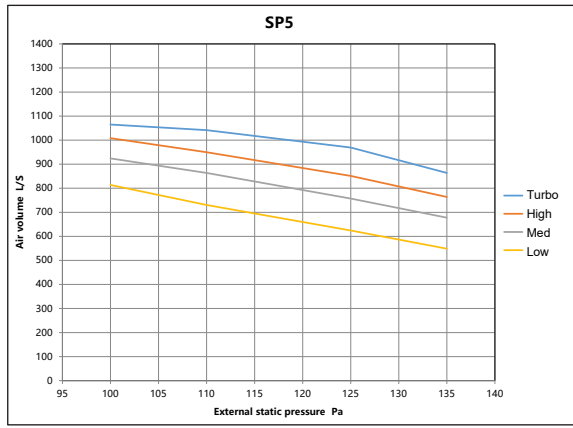
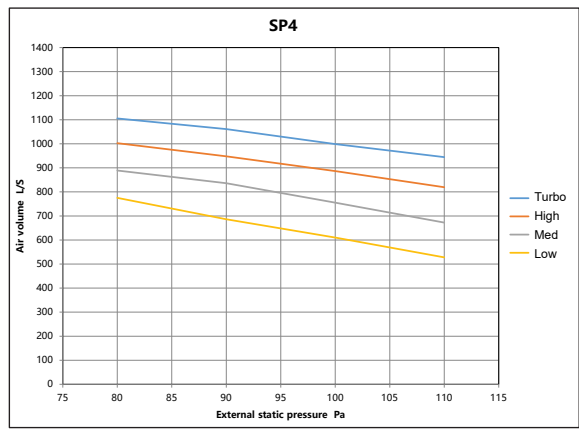
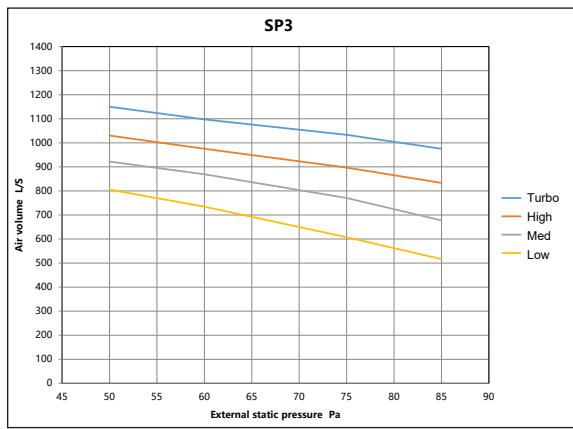
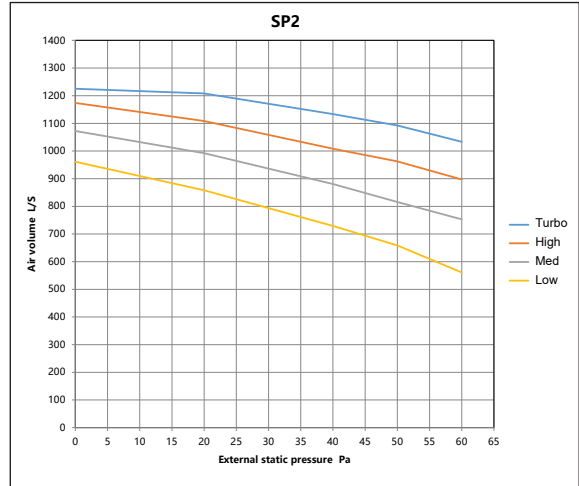
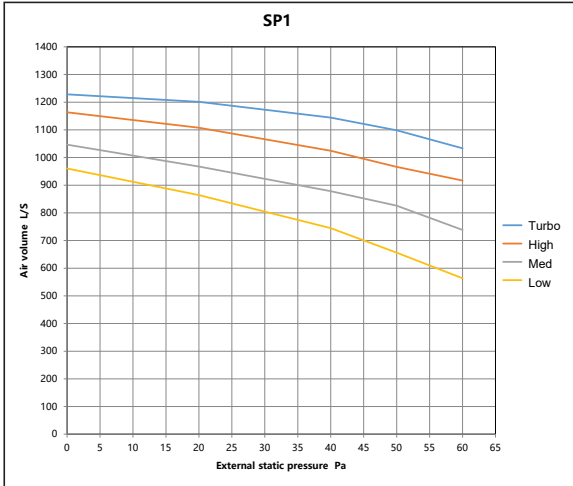

# Setting the system static pressure

All models are set and supplied to a specific static pressure (SP) setting:

Below is a table detailing static pressure settings for all indoor models.

Model	SP1 (default)	SP2	SP3	SP4	SP5	SP6	SP7	SP8
<b>DINLR07B1A</b>	0-25	20-40	40-60	60-80	80-100	100-120	120-140	140-160
<b>DINLR09B1A</b>	0-37	20-40	40-60	60-80	80-100	100-120	120-140	140-160
<b>DINLR11B1A</b>	0-37	37-50	50-75	75-100	100-125	125-150	150-175	175-200
<b>DINLR13B1A</b> <b>DINLR15B1NA/SA</b> <b>DINLR18B1SA</b>	0-50	0-50	50-75	75-100	100-125	125-150	150-175	175-200

To change the system's SP setting or select Auto Fan 9AF) operation through the 120N (CNTRLDRCINW2) controller, do the following:



1. Turn the system OFF at the controller.
2. Press the copy button for 3 seconds, then press enter (tick) to confirm.
3. Press the up or down button to select SP:  
E1-E2-E2B-E3-E4-**SP**-AF-CF
4. Press the enter button to confirm.
5. Press the up or down button to select SP setting. The numbers will be shown on the display in sequence 0 - 1 - 2 - 3 - 4 - 5 - 6 - 7 - 8, select one of these numbers.
6. Press the enter button to confirm.

# Error code summary

## Error display (indoor unit)

When the indoor unit encounters a recognised error, the operation lamp will flash in a corresponding series, the timer lamp may turn on or begin flashing, and an error code will be displayed.

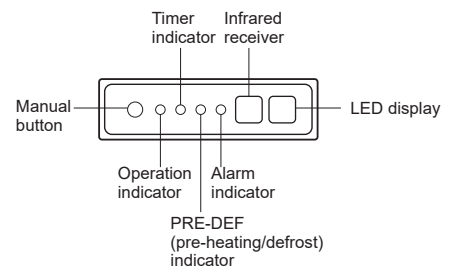

Operation lamp	Timer lamp	Display	Error information
1 time	OFF	EH00 / EH	Indoor unit EEPROM parameter error
2 times	OFF	EL01	Indoor / outdoor unit communication error
4 times	OFF	EH03	Indoor fan speed is operating outside of the normal range
6 times	OFF	EH60	Indoor room temp. sensor T1 is an open circuit or has short circuited
6 times	OFF	EH61	Evaporator coil temp. sensor T2 is in an open circuit or has short circuited
8 times	OFF	EL0C	Refrigerant leakage detection
9 times	OFF	EH0b	Communication error between indoor two chips
13 times	OFF	EH0E	Water level alarm malfunction
5 times	OFF	EC53	Outdoor room temp. sensor T4 is in an open circuit or has short circuited
5 times	OFF	EC52	Condenser coil temp. sensor T3 is in an open circuit or has short circuited
5 times	OFF	EC56	Evaporator coil outlet temp. sensor T2B is in an open circuit or has short circuited
5 times	ON	EC51	Outdoor unit EEPROM parameter error
12 times	OFF	EC07	Outdoor fan speed is operating outside of the normal range
7 times	FLASH	PC00	IPM malfunction or IGBT over-strong current protection
2 times	FLASH	PC01	Over voltage or over low voltage protection
3 times	FLASH	PC02	Top temp. protection of compressor or high temp. protection of IPM module
5 times	FLASH	PC04	Inverter compressor drive error
7 times	FLASH	PC03	High pressure protection or low pressure protection
14 times	OFF	EC0d	Outdoor unit malfunction
--	--	EHbR	Communication malfunction between external fan module and indoor unit
4 times	OFF	EH3R	External DC fan voltage is too low
4 times	OFF	EH3b	External DC fan voltage is too high
1 time	ON	--	Indoor units mode conflict with outdoor unit
--	--	EH63	Displays on wired wall controller only Communication error between wired controller and indoor unit

# Wired wall controller: Queries and settings



## Query mode

To enter into 'query' mode, long press the COPY button for more than three seconds. P:00, if connected to an indoor unit will display. If connected to multiple indoor units, press the up or down button to display P:01, P:02, and then press the CONFIRM button to query the indoor unit.



- Tn (T1~T4) temperature, and
- CF (fan fault), press the up or down buttons to select.



## Exiting query and setting modes

You can exit the query or setting mode by pressing either the Back or On/Off button. The controller will also exit automatically if no buttons are pressed for more than 15 seconds



## Accessing the static pressure values (SP)

With the indoor unit off, within the query function of 'temperature', press the up or down buttons to select SP. Press confirm to adjust the static pressure value.



## Accessing Airflow (AF) Function

The AF (Aerostatic Function) helps reduce installation time by automatically adjusting the external static pressure between the ducted unit and the duct system. When activated, the AF function detects the duct's external static pressure and automatically sets the appropriate airflow volume to ensure optimal performance.

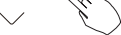

To run the AF test:

1. Ensure the indoor unit is turned off.
2. Enter the query function and select 'Temperature'.
3. Use the up or down buttons to select AF.
4. Press confirm to enter test mode (the display will flash 'ON').
5. The AF test will automatically run and complete within 3 to 6 minutes, adjusting the airflow based on the measured external static pressure.



## Accessing Follow Me temperature compensation

With the indoor unit off, within the query function of 'temperature', press the up or down buttons to select tF. Press confirm to get into the setting, and select the up or down buttons to change the settings, and confirm to complete. The range is -5~5 °C.



## Operational modes within temperature query

This allows you to predefine how the system should behave when it's turned on again—whether it should be capable of both heating and cooling or restricted to one mode only.



With the indoor unit off, within the query function of 'temperature', press the up or down buttons to select tYPE. Press confirm to get into the setting, and select the up or down buttons to select the mode, and confirm to complete. There are four modes; CH (cooling and heating), HH (heating only), CC (cooling only), and NA.

CH:   
AUTO COOL DRY HEAT FAN

HH:   
HEAT FAN

CC:   
COOL DRY FAN

NA:   
COOL DRY HEAT FAN

NA means the system can operate in any manual mode but cannot automatically switch between heating and cooling.

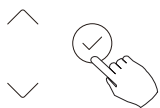

### Setting the highest and lowest temperature values

With the indoor unit off, within the query function of 'temperature', press the up or down buttons to select tHI or tLo. Press confirm to get into the setting, and select the up or down buttons to select the temperature, and confirm to complete.

- High temperature range: 25~30 °C
- Low temperature range: 16~24 °C



Highest value setting function

Minimum value setting function

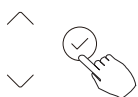

### Remote Control Function (rEC) – Wired Controller Setting

This setting determines whether the wired wall controller will accept remote control signals (e.g., from an infrared remote or central control system).



How to access and configure:

1. Ensure the indoor unit is turned off.
2. Enter the temperature query mode by pressing the up or down buttons.
3. Scroll until you see 'rEC' on the display.
4. The temperature display area will show either:
  - ON – remote control signals are enabled (the wired controller will respond to them).
  - OF – remote control signals are disabled (the wired controller will ignore any remote commands).
5. Press confirm to enter the setting.
6. Use the up or down buttons to toggle between ON and OF.
7. Press confirm again to save your selection.

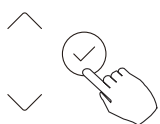

### Two line controller address selection

With the indoor unit off, within the query function of 'temperature', press the up or down buttons to select Adr, the temperature area will display -- or A,B.



-- refers to the code setting of the wired controller. Press confirm to get into the setting, and select the up or down buttons to select, and confirm to complete.

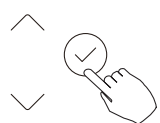

### Restore Factory Settings (INIt Function)

This function resets the controller to its original factory configuration.



1. With the unit off, enter the temperature query mode using the up/down buttons.
2. Scroll to find INIt.
3. The temperature display will show '--', indicating it's ready to reset.
4. Press confirm to enter the setting.
5. Use the up/down buttons to select ON.
6. Press confirm again to complete the reset.

After restoring factory settings the rotating parameter setting is restored to ten hours<sup>1</sup>, the system reverts to its default range with no temperature compensation.

<sup>1</sup> Ten hours rotating refers to when one wired controller controls two indoor units which operate alternately with a default switching interval of ten hours.

# Wiring diagram: Indoor 7-15 kW (non-splittable)

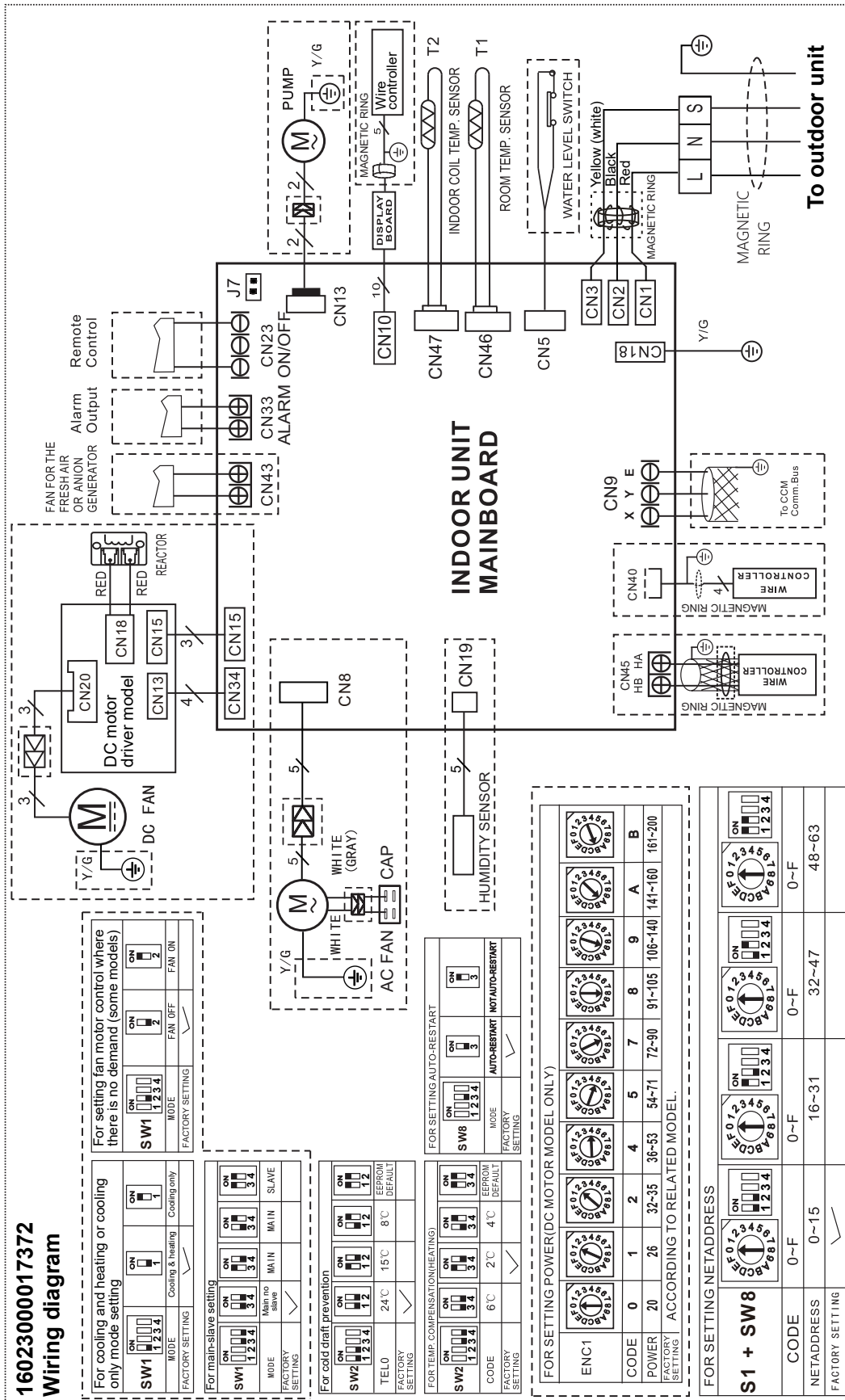

**Note**

1. This symbol highlights optional components, refer to the actual product for more detail.
2. Remove the short connector of J7 when you use the 'on-off' function.
3. When the wire controller uses the shielder wire, the shielded wire should be properly grounded.

# Wiring diagram: Indoor 15-18 kW (splittable)

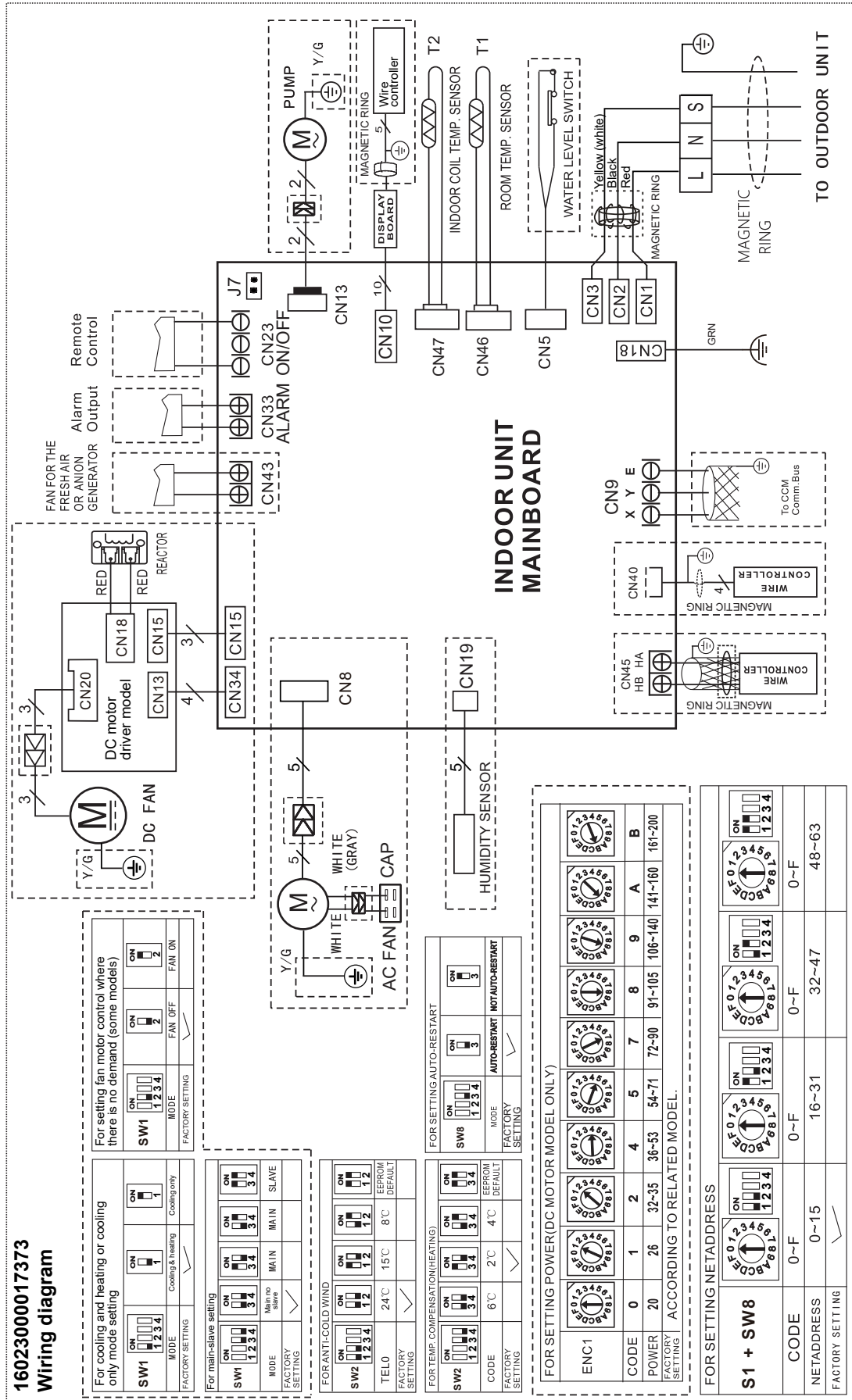

# Wiring diagram: Outdoor 7 kW

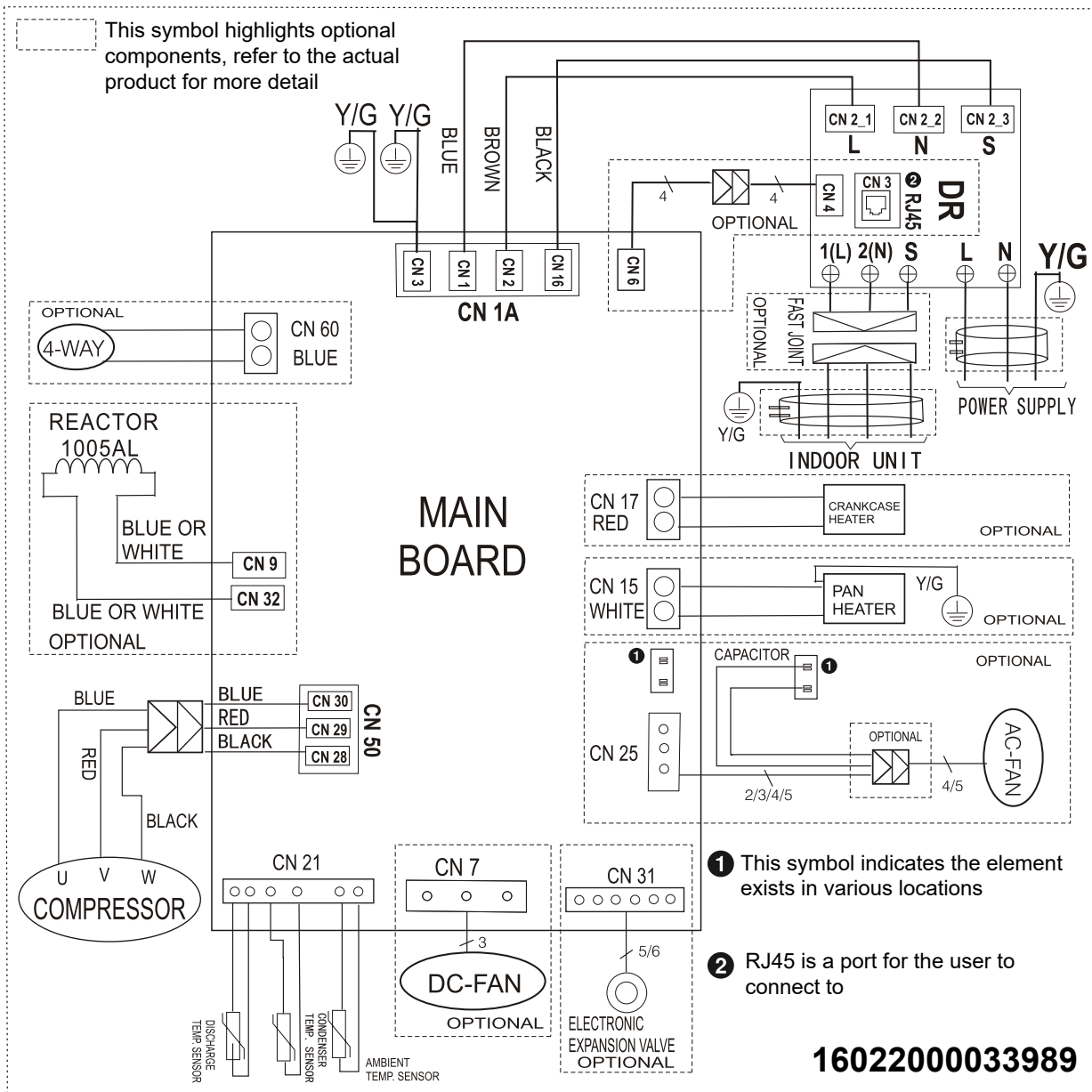

# Wiring diagram: Outdoor 9 kW

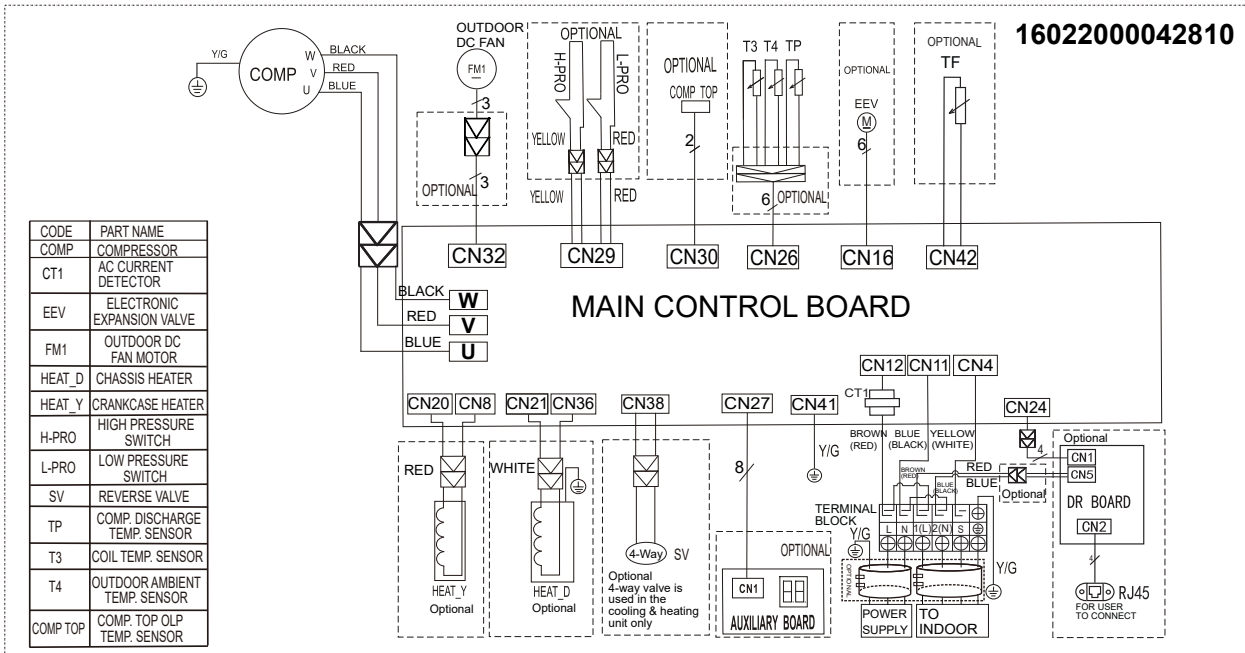

This symbol highlights optional components, refer to the actual product for more detail

# Wiring diagram: Outdoor 11-15 kW (non-splittable)

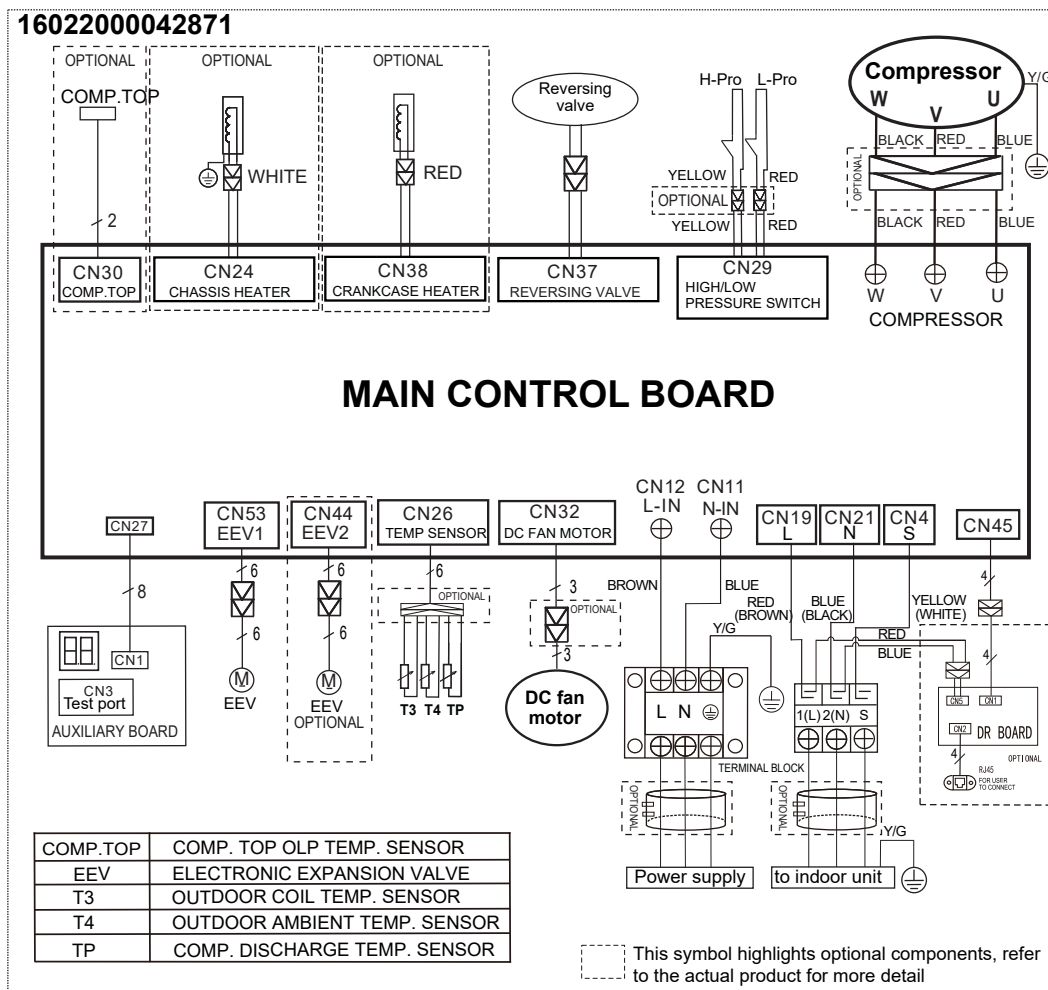

This symbol highlights optional components, refer to the actual product for more detail

# Wiring diagram: Outdoor 15-18 kW (splittable)

16022000042830

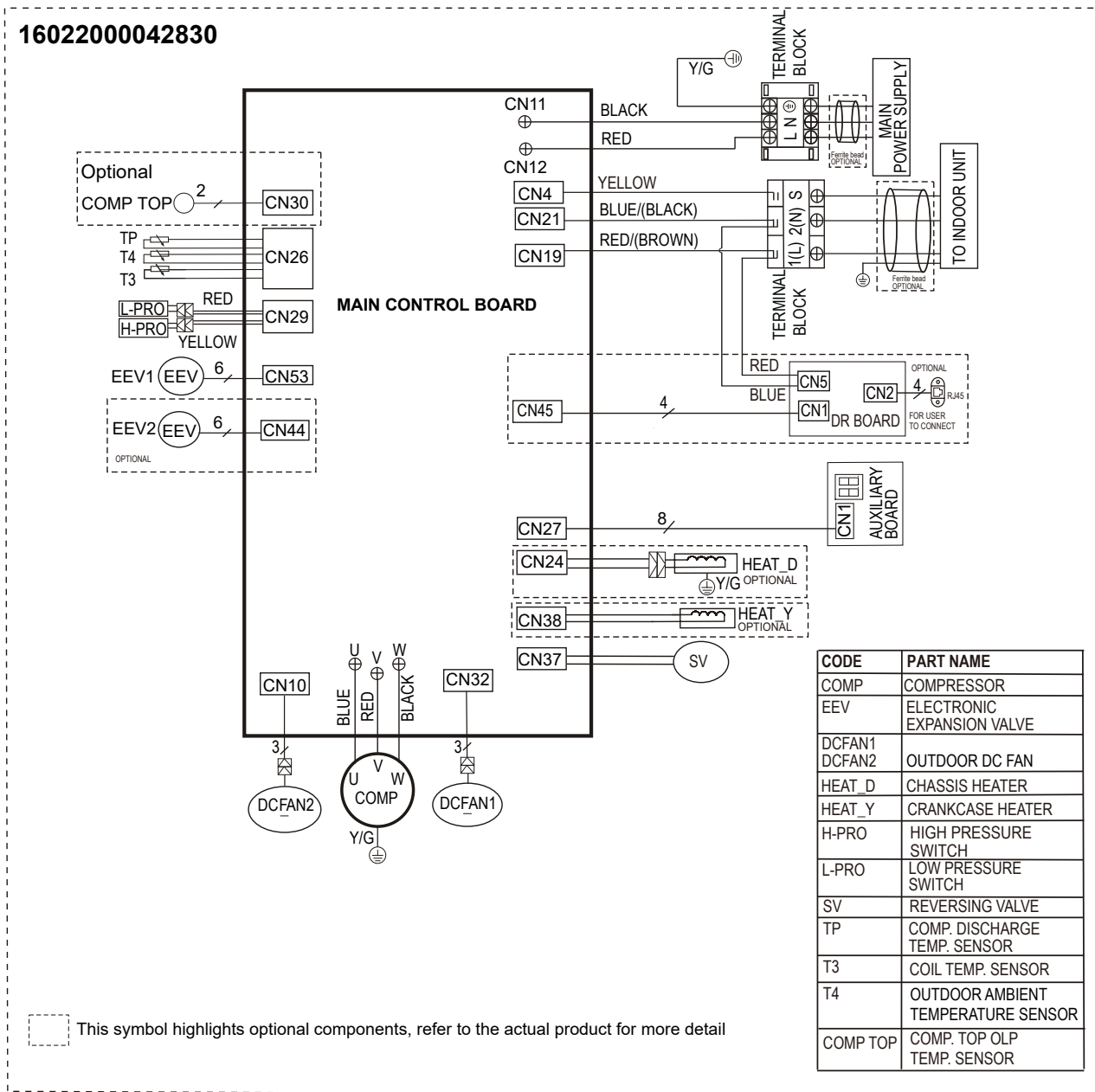

**Rinnai.co.nz**

Tel: 0800 746 624  
<http://www.youtube.com/rinnainz>  
<http://facebook.com/rinnainz>

Pro Series ducted central heating & cooling installation guide  
14097-H | 8-26