

INFINITY NB56kW_i internal water heater
Polypropylene (PP) common flue installation guide

Rinnai

Important

Rinnai INFINITY NB56kWi internal gas hot water heater flueing shall be installed in accordance with:

- Manufacturer's installation instructions
- Current AS/NZS 3000, AS/NZS 3500, AS/NZS 5601.1 and G12/AS1

The flueing components outlined in this guide are suitable for the NB56kWi model only.

For use with Natural Gas or Universal LPG as indicated on the appliance.

Appliance must be installed, commissioned and serviced by an authorised person, being in New Zealand a licensed gasfitter.

Warning

Improper installation, adjustment, alteration, service and maintenance can cause property damage, personal injury or loss of life.

For more information about buying, using, and servicing of Rinnai appliances call: 0800 RINNAI (0800 746 624).

Rinnai New Zealand Limited
105 Pavilion Drive, Mangere, Auckland
PO Box 53177, Auckland Airport, Auckland 2150

Phone: (09) 257-3800
Email: info@rinnai.co.nz
Web: rinnai.co.nz
[youtube.com/rinnainz](https://www.youtube.com/rinnainz)
[facebook.com/rinnainz](https://www.facebook.com/rinnainz)

Contents

Flueing options	4
Flueing guidelines.....	6
Spacing the water heaters.....	7
Condensate	7
Installation guidelines	8
Terminations	10
Air requirements for gas appliances.....	11
Flue selection	13
Room air flueing	14
Outside air flueing.....	15
Vertical termination kits.....	16
Horizontal termination kits	17
Component dimensions.....	18

Important

The flue components outlined in this guide are suitable for up to **seven** NB56kWi water heaters, these flue components are stocked ex-Auckland. For applications using more than seven water heaters, contact Rinnai Commercial for specification assistance. These flue components would need to be specially ordered and there may be a lead time.

To ensure accurate flueing dimensions, before cutting any components, it is a good idea to remove the seals and connect the system to double-check everything fits.

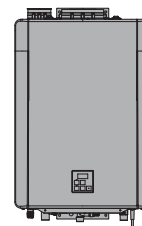

Flueing options



Single skin polypropylene common flueing (zero clearance) is designed for use with the Rinnai INFINITY NB56kWi internal model only. It is not suitable for use with any other Rinnai INFINITY models.

For all applications the flue must pitch back to the water heater at a constant 3° pitch (54 mm per metre) to drain condensate.

Rinnai header components are cut (and only suitable) for water heaters mounted on 521 mm centres, and if back-to-back, 159 mm spacing. NB56kWi flueing is available with the header configurations shown below.

Unit spacing required

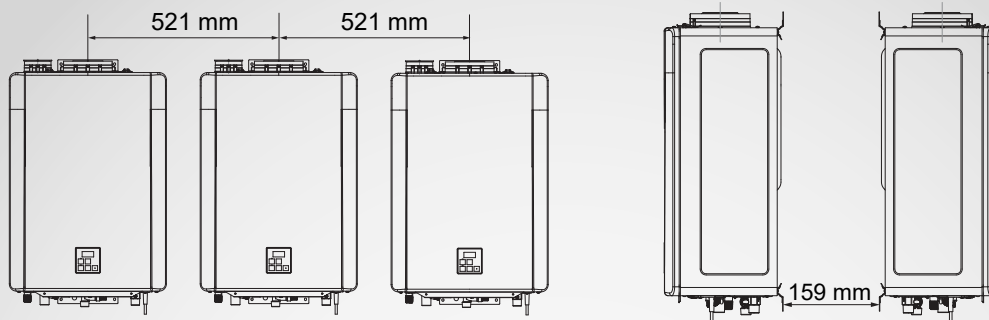

Room air header configurations

Multiple water heaters using room air for combustion while sharing an exhaust header that vents directly outside. A room air adapter is fitted (as pictured) to the top of each water heater.

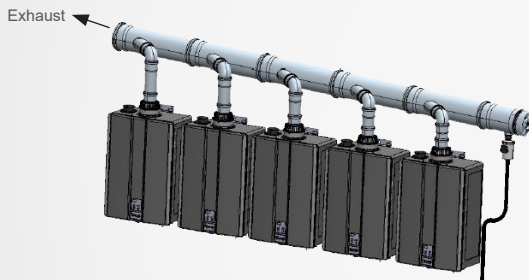
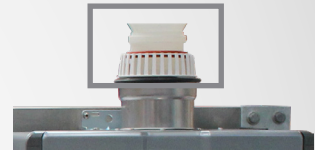

Room air inline header

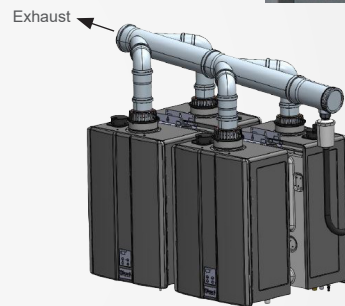

Room air back-to-back header

Outside air header configurations

Multiple water heaters share a combustion air header and a separate exhaust header that vents directly through separate penetrations to the outside.

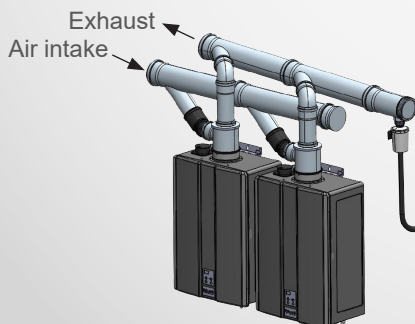

Outside air inline header

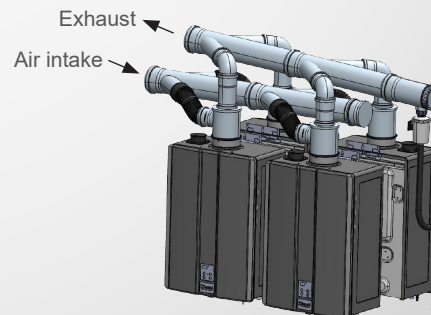

Outside air back-to-back header

Room air back-to-back flueing example

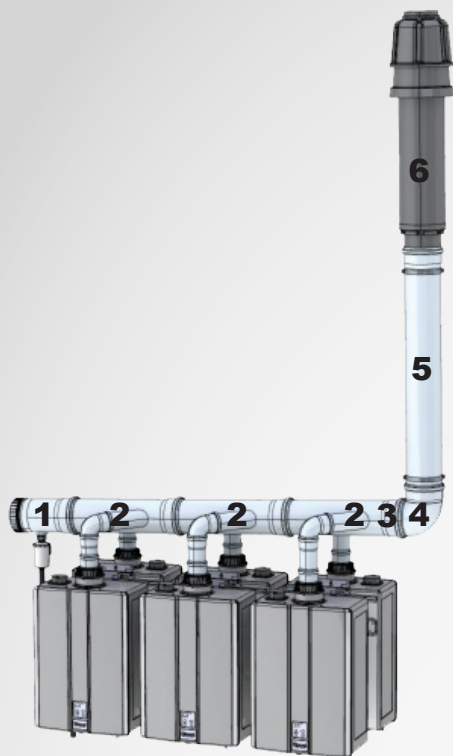

1. CFKRS110: Room air starter kit Ø110 mm
2. CFKRCB110: Room air back-to-back connection kit Ø110 mm
3. Ø110-160 mm adapter
Part of the vertical termination kit
4. CF790087: 90° bend Ø160 mm
5. CF790089: Flue pipe 1m Ø160 mm
6. CFKRVT160: Room air Ø160 mm vertical termination kit
Includes a UV stainless steel sleeve and an exhaust rain cap (not shown).

Outside air back-to-back flueing example

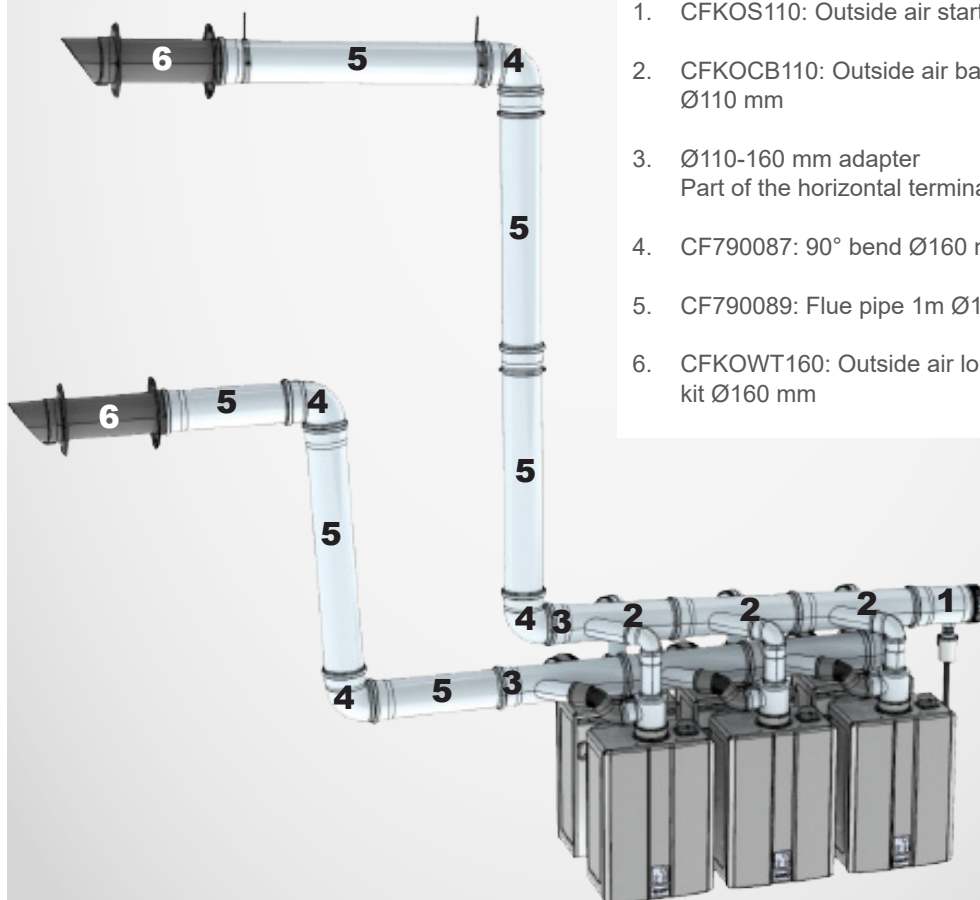

1. CFKOS110: Outside air starter kit Ø110 mm
2. CFKOCB110: Outside air back-to-back connection kit Ø110 mm
3. Ø110-160 mm adapter
Part of the horizontal termination kit
4. CF790087: 90° bend Ø160 mm
5. CF790089: Flue pipe 1m Ø160 mm
6. CFKOWT160: Outside air long horizontal termination kit Ø160 mm

Flueing guidelines

Combustion air provided to the system should not be taken from any area that may produce a negative pressure (i.e exhaust fans, powered ventilation fans etc.). Room combustion air requires compliant louvres in a plant room door or wall, refer AS/NZS 5601.1 for more information.

For appliance and user safety NEVER use Rinnai flue components with other manufacturer's water heaters.

Maximum flue length

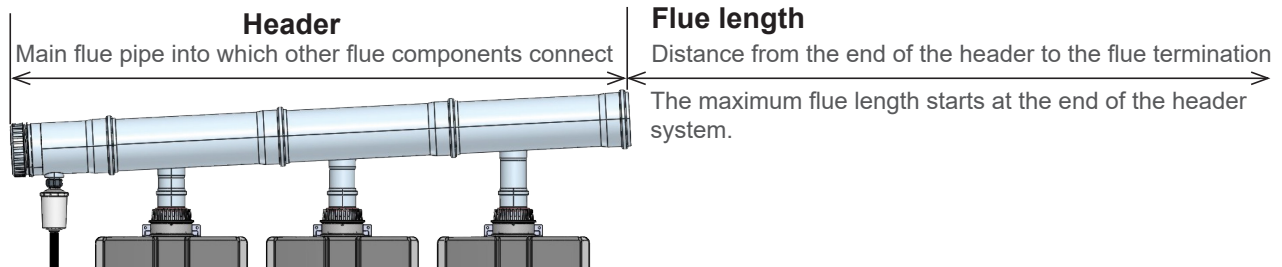

Header size		Header size
Ø110 mm header Ø110 mm flue	Ø110 mm header Ø160 mm flue	Ø160 mm header Ø160 mm flue
Horiz. termination ONLY	Horiz. and vertical termination	Horiz. and vertical termination

Please note: For every 90° bend used, subtract 3 m from the lengths below

Number of water heaters	Maximum flue length		
2	45 m	45 m	
3	45 m	45 m	
4	20 m	45 m	
5		45 m	
6		45 m	
7		21 m	45 m
8			45 m
9			27 m
10			27 m
11			12 m
12			12 m

UV protection

Where appropriate, all components must be protected from UV. The horizontal terminals are UV resistant. The vertical terminals are supplied with a stainless outer for UV protection. Anything else exposed to UV should be painted with a system suitable for polypropylene.

Spacing the water heaters

If you are not using a Rinnai pre-assembled skid system it's important to note that the Rinnai header flue components are cut (and only suitable) for water heaters mounted on 521 mm centres, and if back-to-back, 159 mm spacing (refer image on p.4).

Install the flueing according to configuration outlined below. Do not locate the common header remotely from the water heaters. Room air configurations follow the same instructions excluding the information regarding the air intake.

The installation areas should be measured to make sure that adequate space is available to install the water heaters and the flue system.

Back-to-back configuration example

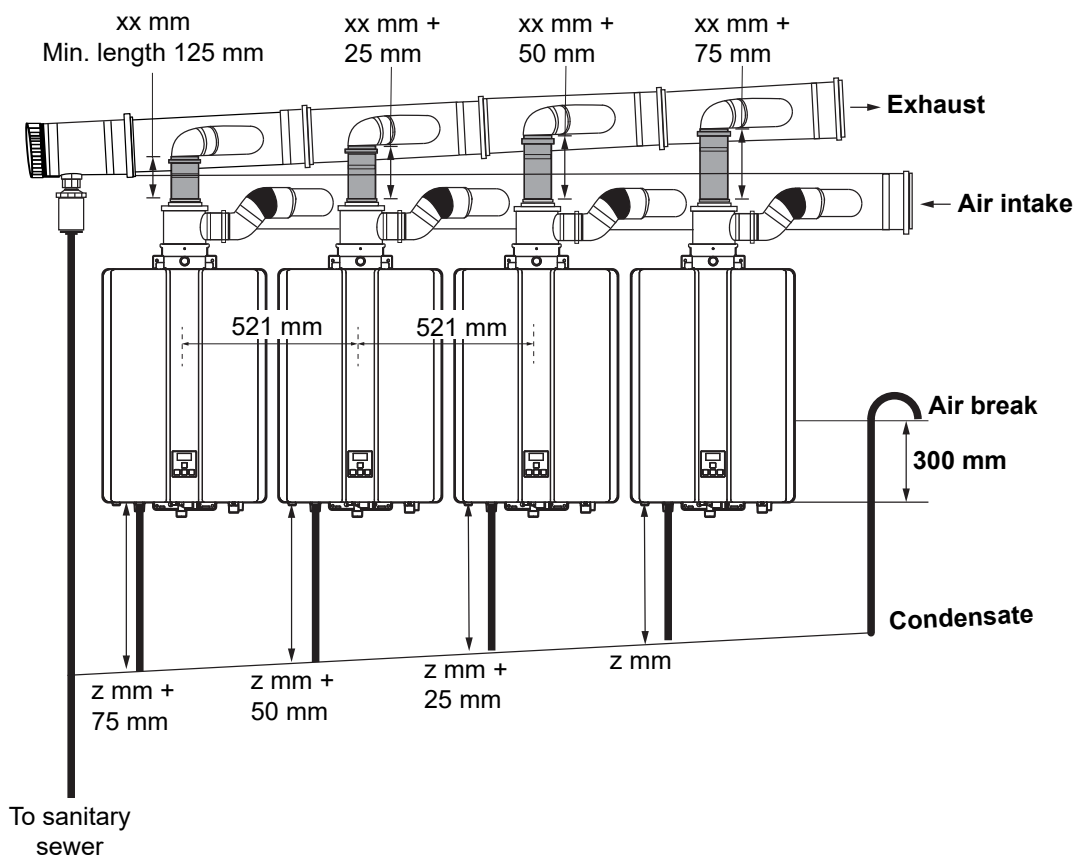

Condensate

This information should be used in conjunction with the condensate section within the 'NB-Series installation guide'. Install the condensate trap and drain pipe.

The starter kit (end cap) collects condensate—a condensate trap is supplied with each starter kit. The condensate trap has an integrated valve that temporarily blocks condensate if high (wind) pressures cause a pressure rise in the system. The integrated valve will also prevent the trap from drying out if the system is off for a long period of time. The condensate trap does not require priming.

Condensate must be drained to prevent malfunction, diagnostic code failures, or property damage.

Installation guidelines



Rinnai's common flue components are designed to fit the NB56kWi water heaters that are mounted securely and spaced 521 mm apart (centre to centre).

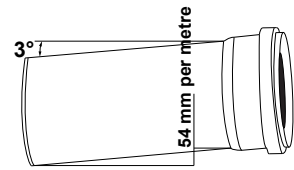

Exhaust flueing is designed for a 3° rise (54 mm per metre) back to the water heater to drain condensate—this **MUST BE** done.

Install water heater adapters

Install the appliance adapters on top of the water heater with a self tapping screw.

Calculate extension pipe sizes

As noted above, exhaust venting is designed for a 3° rise (54 mm per metre). When the water heaters are spaced 521 mm (centre to centre), the height increase is approx. 25 mm per water heater. A 500 mm extension section is included with each connection kit, this **MUST BE** cut to length to account for the rise from unit to unit, refer shaded pipe —sections on previous page.

# of units	Pipe length
1	125 mm
2	150 mm
3	175 mm
4	200 mm
5	225 mm
6	250 mm
7	275 mm
8	300 mm

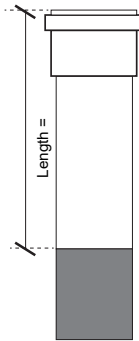

Important

To get the header pitch, each extension pipe needs to be 25 mm longer than the previous pipe. The minimum length for the extension pipe is 125 mm.

Install bends

Install the bends to the extension section. Do not cut or modify the bend.

Header connection

Install the header components as shown below. For outside air flueing, connect the combustion air opening of the appliance adapter to one end of the flex connector, and the other end of the flex connector to the combustion air header.

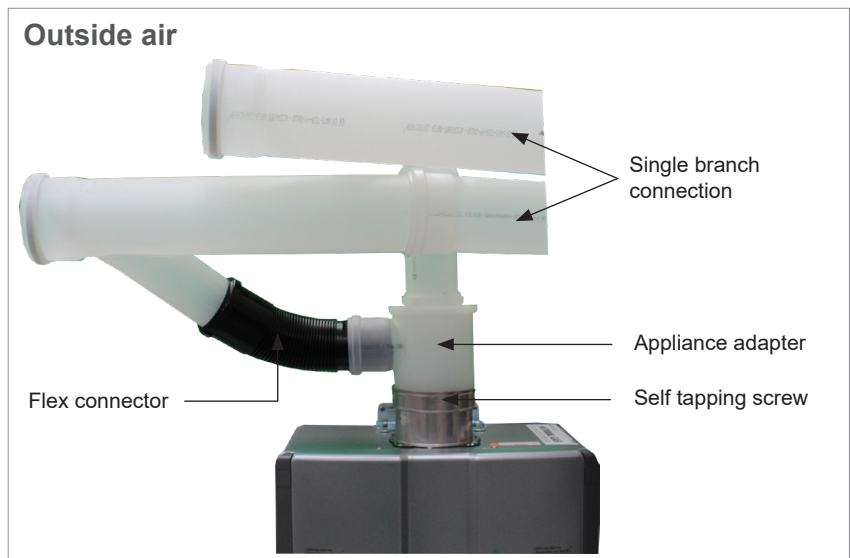

Joining, disconnecting, and cutting

For measuring, the seals can be temporarily removed.

Lubricate the seals and male ends of the components with Centrocerin lubricant or water, and assemble the components using light rotational movements. Fully insert the male end into the female end. Immediately inspect the seal to make sure it is in the correct position.

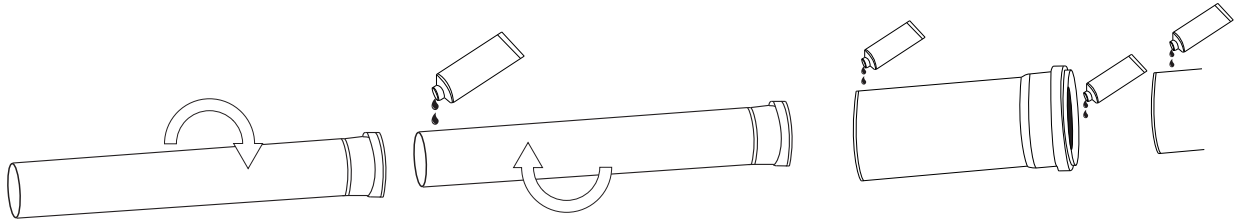

The pipes are always shortened on the male end. After cutting (cut straight), always deburr and bevel the end so the sealing gaskets are not damaged. Never cut or modify formed components such as elbows or collectors.

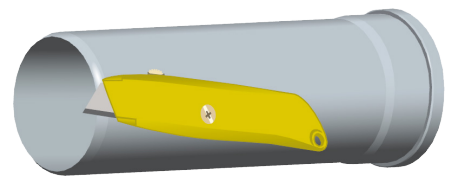

Seal direction and assembly of seals

Seals are pre-assembled in the flue components. If a seal is damaged it should not be used. Use only original seals. NEVER use fabricated or non-Rinnai flue seals or parts.

- The seal must remain clean and free from foreign debris before assembly.
- Always confirm the seal is installed in the right direction.

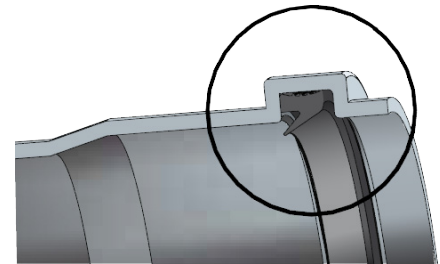

Flue supports

- Support horizontal flue runs a minimum of every 1.2 m
- Support vertical flue runs a minimum of every 1.8 m

Flue supports are not provided with any of the kits—they must be ordered separately, refer p.16 for part numbers.

Lubricant

The seals and male ends of all common flue components must be lubricated before assembly. Only use the Centrocerin lubricant provided with each starter kit, or water. One tube of Centrocerin is enough for approximately 30 m of flue. Centrocerin is a water soluble lubricant designed to ease assembly of flue components. Other lubricants are not suitable as they will damage the flue.



Centrocerin lubricant is provided, but can also be purchased separately—part CF790025.

Flue direction

The female end of the flue must always point in the direction of the termination. This is critical to ensure proper condensate flow and to maintain the integrity of the seals.

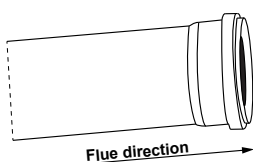

Terminations

Vertical terminations

To ensure products of combustion are cleared, adequate clearance from the building is required. The vertical cowl should have a 500 mm clearance from any part of the building. This also applies to steep and pitched roofs, where the flue cowl should be 500 mm clear of the ridge line. An adequate flow of fresh air must exist around the flue cowl following installation.

Minimum clearances are shown in AS/NZS 5601.1.

For outside air vertical terminations there also needs to be a 305 mm minimum clearance, inside edge to inside edge, between the intake and exhaust terminals.

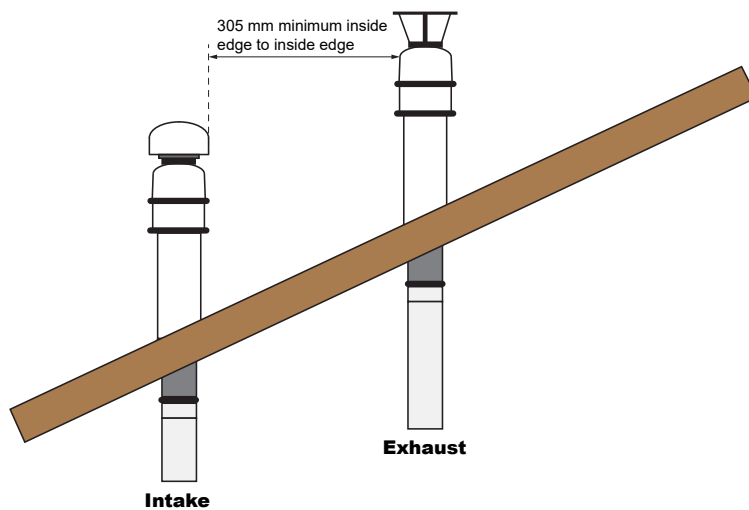

Horizontal terminations

Horizontal terminations must also comply with shown in AS/NZS 5601.1.

For outside air horizontal terminations there needs to be a 305 mm minimum clearance, from edge of exhaust termination to edge of combustion air termination.

Please note

During colder weather when the exhaust temperature is much hotter than the outside air, the exhaust fumes will condense, producing water vapour. As a result a plume of water vapour may be seen leaving the exhaust.

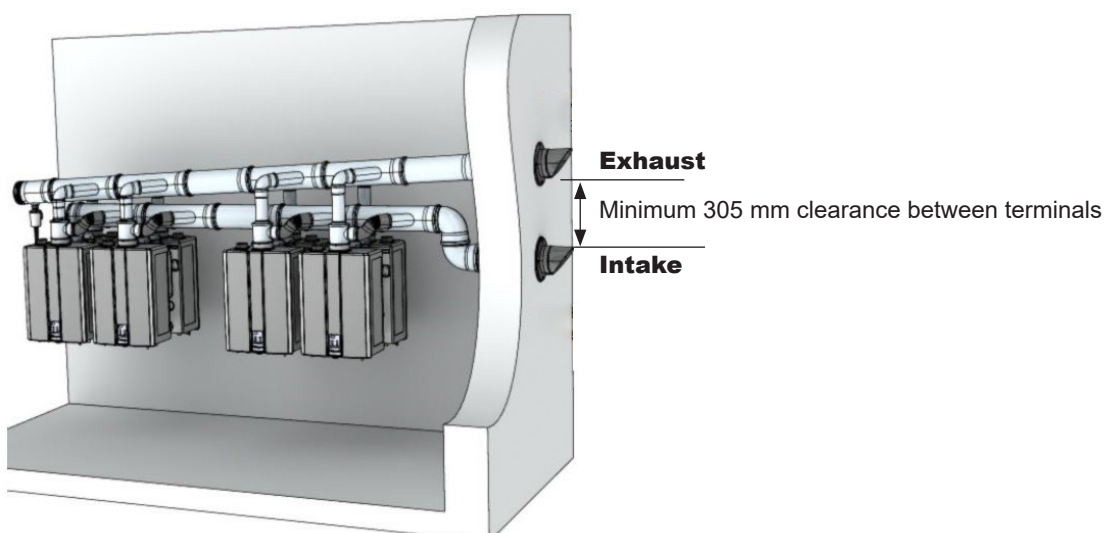

Air requirements for gas appliances



This system requires adequate combustion air for ventilation and dilution of flue gases. Failure to provide adequate combustion air can result in an unsafe situation.

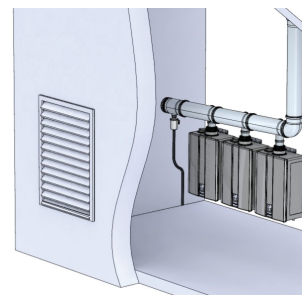

As detailed in AS/NZS 5601.1 p.100-101, two permanent ventilation openings, with calculated ventilation areas, shall be provided. The openings can be combined provided it complies with AS/NZS 5601.1 6.4.5 'Location of ventilation openings'.

Appliances using room air for combustion

To calculate the air requirements for NB56kW installations you must reference AS/NZS 5601.1 6.4.4 'Air requirements for gas appliances'. For ease of reference we have provided the total MJ/h input rating in the table below, to assist with this calculation.

Air for NB56kW installations only (in addition to other appliances)

PLANT ROOM						
Number of NB56kW units	2	3	4	5	6	7
Factor direct to outside	150	150	150	150	150	150
Max. MJ/h input rate	418	627	836	1045	1254	1463
Ventilation required in mm ² (x 2)	62700	94050	125400	156750	188100	219450
Factor via an adjacent room	300	300	300	300	300	300
Max. MJ/h input rate	418	627	836	1045	1254	1463
Ventilation required in mm ² (x2)	125400	188100	250800	313500	376200	438900

NON-PLANT ROOM						
Number of NB56kW units	2	3	4	5	6	7
Factor direct to outside	300	300	300	300	300	300
Max. MJ/h input rate	418	627	836	1045	1254	1463
Ventilation required in mm ² (x2)	125400	188100	250800	313500	376200	438900
Factor via an adjacent room	600	600	600	600	600	600
Max. MJ/h input rate	418	627	836	1045	1254	1463
Ventilation required in mm ² (x2)	250800	376200	501600	627000	752400	877800

General requirements for combustion air

Combustion air must be free of corrosive chemicals. Do not provide combustion air from corrosive environments. System failure due to corrosive air is not covered by warranty.

Combustion air must be free from acid forming chemicals such as sulphur and chlorine. These chemicals have been found to cause rapid damage and decay, and become toxic when used as combustion air in gas appliances. Such chemicals can be found in, but not limited to, bleach, ammonia, aerosol sprays, cleaning solvents, varnish, paint, and air fresheners. Do not store these or similar products in the vicinity of the water heaters.

INFINITY NB56kWi internal water heater

Flue kits and components

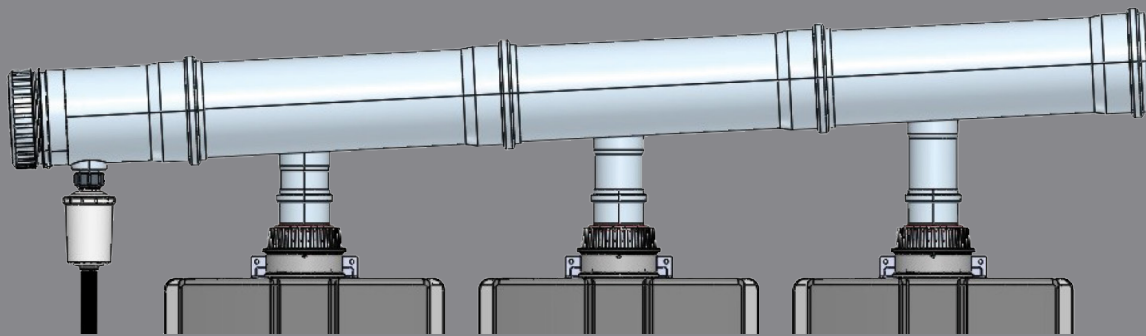

Flue selection

1. Refer table on next page
- 2a. Select appropriate starter kit
- 2b. Select appropriate header connection kit(s)
3. Select appropriate termination kit
4. Select respective flue pipes and bends
(double quantities for outside air)

Flue selection

2a. Starter kits , one starter kit is required for each application			
Kit	Part number	Contains	
Room air starter kit	CFKRS110	<ul style="list-style-type: none"> Room air vent Condensate trap and 1.2 m rubber hose Centrocerin lubricant 	
Outside air starter kit	CFKOS110	<ul style="list-style-type: none"> Room air vent End cap Condensate trap and 1.2 m rubber hose Centrocerin lubricant 	
2b. Header connection kits , inline—one kit for each water heater, back-to-back—one kit for every two water heaters			
Room air inline connection kit	CFKRCS110	<ul style="list-style-type: none"> Collector Ø110 mm 1-branch Bend 90° Extension 500 mm Room air adapter 	
Room air back-to-back connection kit	CFKRCS110	<ul style="list-style-type: none"> Collector Ø110 mm 2-branch Bend 90° (x2) Extension 500 mm (x2) Room air adapter (x2) 	
Outside air inline connection kit	CFKOCS110	<ul style="list-style-type: none"> Collector Ø110 mm 1-branch (x2) Bend 90° Extension 500 mm Outside air adapter and rubber flex 	
Outside air back-to-back connection kit	CFKOCS110	<ul style="list-style-type: none"> Collector Ø110 mm 2-branch (x2) Bend 90° (x2) Extension 500 mm (x2) Outside air adapter and rubber flex (x2) 	
3. Horizontal termination kits			
Room air Ø110 mm horizontal termination kit	CFKRWT110	<ul style="list-style-type: none"> Wall terminal kit Ø110 mm 	
Outside air Ø110 mm horizontal termination kit	CFKOWT110	<ul style="list-style-type: none"> Wall terminal kit Ø110 mm (x2) 	
Room air Ø160 mm horizontal termination kit	CFKRWT160	<ul style="list-style-type: none"> Wall terminal kit Ø160 mm Ø110-160 mm adapter 	
Outside air Ø160 mm horizontal termination kit	CFKOWT160	<ul style="list-style-type: none"> Wall terminal kit Ø160 mm (x2) Ø110-160 mm adapter (x2) 	
3. Vertical termination kits			
Room air Ø160 mm vertical termination kit	CFKRVT160	<ul style="list-style-type: none"> Vertical terminal Stainless UV sleeve Exhaust rain cap Ø110-160 mm adapter 	
Outside air Ø160 mm vertical termination kit	CFKOVVT160	<ul style="list-style-type: none"> Vertical terminal (x2) Stainless UV sleeve (x2) Exhaust rain cap Intake rain cap Ø110-160 mm adapter (x2) 	

Room air flueing

NB56kWi common header (diam. 110 mm) room air inline flueing

Flueing system must start with a starter kit (one per system), and a connection kit (one for each water heater). These are detailed below.

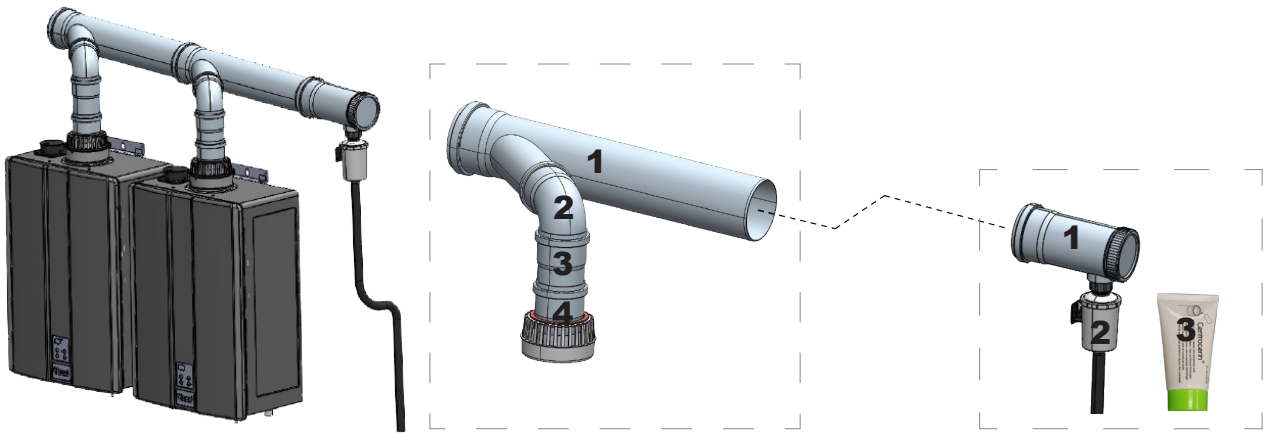

CFKRS110: Room air inline connection kit contains:

1. Collector Ø110 mm 1-branch
2. Bend 90°
3. Extension 500 mm
4. Room air adapter

CFKRS110: Room air starter kit contains:

1. Room air vent
2. Condensate trap and 1.2 m rubber hose
3. Centrocerin lubricant

NB56kWi common header (diam. 110 mm) room air back-to-back flueing

Flueing system must start with a starter kit (one per system), and a connection kit (one per two water heaters). These are detailed below.

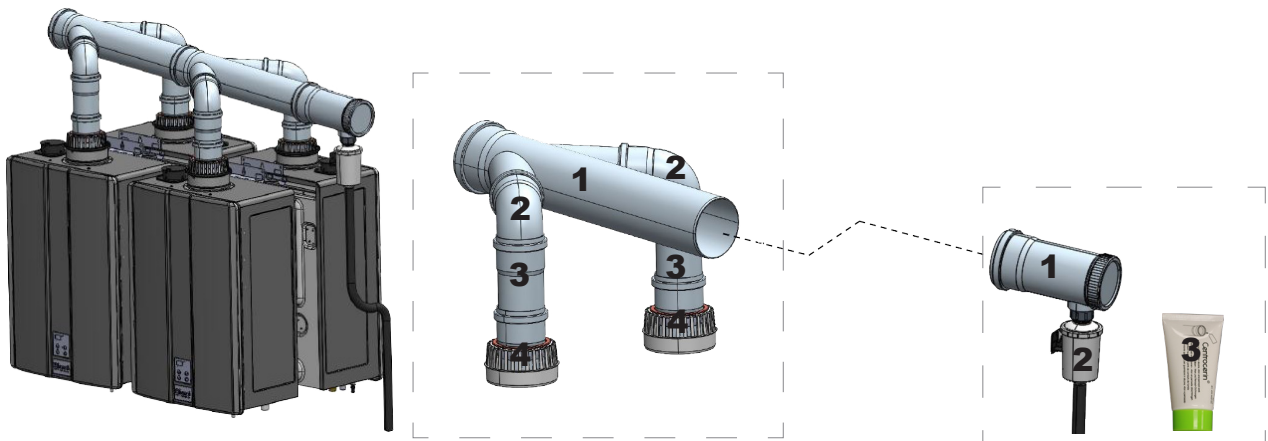

CFKRCB110: Room air back-to-back connection kit contains:

1. Collector Ø110 mm 2-branches
2. Bend 90° x 2
3. Extension 500 mm x 2
4. Room air adapter x 2

CFKRS110: Room air starter kit contains:

1. Room air vent
2. Condensate trap and 1.2 m rubber hose
3. Centrocerin lubricant

Outside air flueing

NB56kW common header (diam. 110 mm) outside air inline flueing

Flueing system must start with a starter kit (one per system), and a connection kit (one for each water heater). These are detailed below.

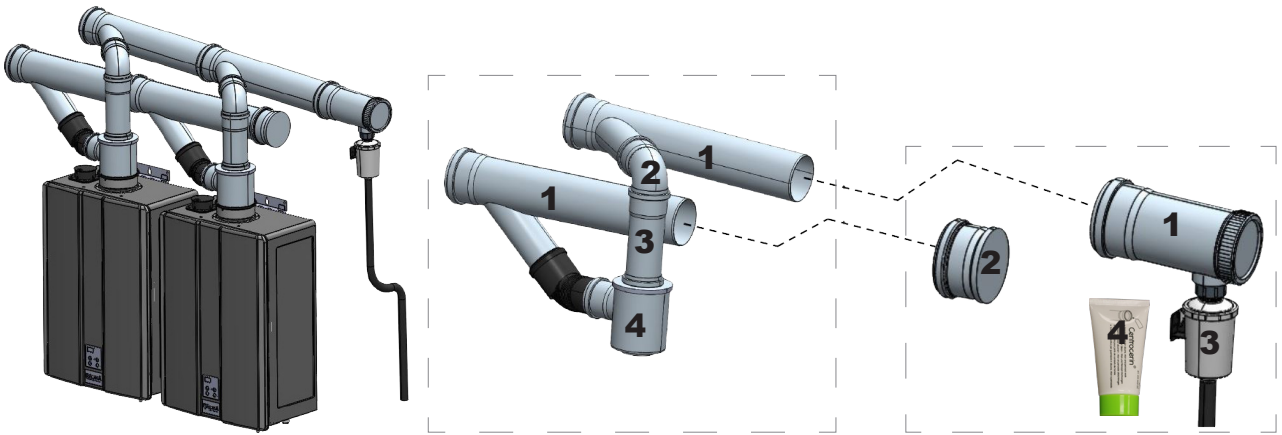

CFKOC110: Outside air inline connection kit contains:

1. Collector Ø110 mm 1-branch x 2
2. Bend 90°
3. Extension 500 mm
4. Combustion air adapter and flex

CFKOS110: Outside air starter kit contains:

1. Room air vent
2. End cap
3. Condensate trap and 1.2 m rubber hose
4. Centrocerin lubricant

NB56kW common header (diam. 110 mm) outside air back-to-back flueing

Flueing system must start with a starter kit (one per system), and a connection kit (one per two water heaters). These are detailed below.

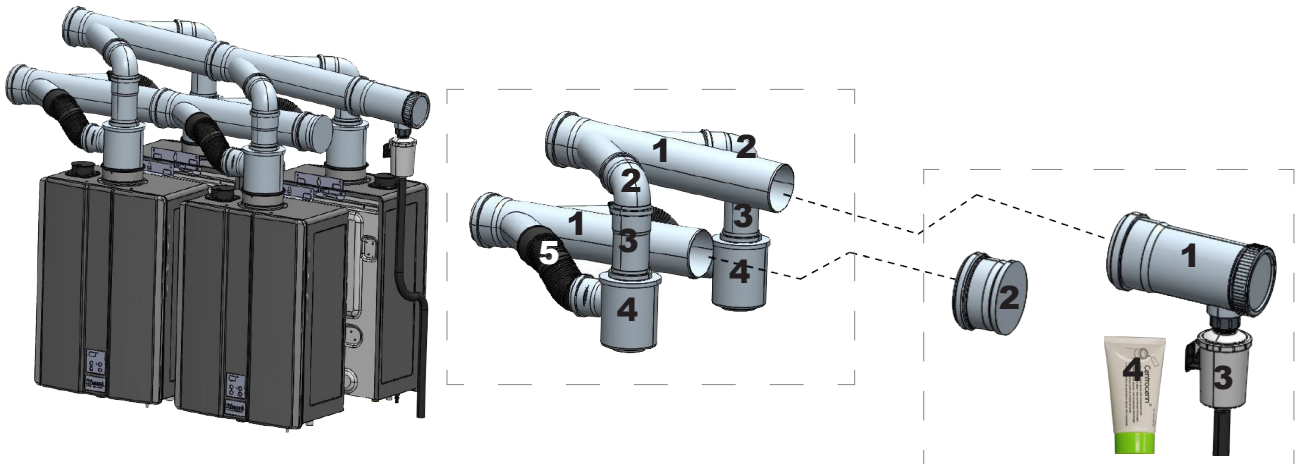

CFKOCB110: outside air back-to-back 110 connection kit contains:

1. Collector Ø110 mm 2-branches x 2
2. Bend 90° x 2
3. Extension 500 mm x 2
4. Combustion air adapter and flex x 2

CFKOS110: Outside air starter kit contains:

1. Room air vent
2. End cap
3. Condensate trap and 1.2 m rubber hose
4. Centrocerin lubricant

Vertical termination kits

CFKRVT160: NB56kWi 160 mm room air vertical termination kit

Kit contains:

- Vertical terminal
- Stainless UV sleeve
- Ø110-160 mm adapter
- Exhaust rain cap



CFKOV160: NB56kWi 160 mm outside air vertical termination kit

Kit contains:

- Vertical terminal x2
- Stainless UV sleeve x2
- Ø110-160 mm adapter x2
- Exhaust rain cap x1
- Intake rain cap x1



Flue support part numbers

Refer note on p.9, flue supports need to be ordered separately.

- Flue support/bracket Ø110 mm part number: CF790091
- Flue support/bracket Ø160 mm part number: CF790092

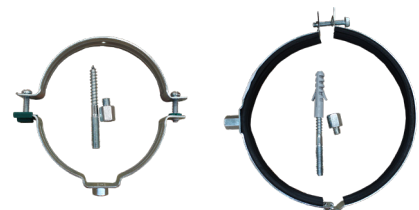

Horizontal termination kits

CFKRWT110: NB56kWi 110 mm room air horizontal termination kit (four or less water heaters)

Kit contains:

- Horizontal termination 110 mm



CFKRWT160: NB56kWi 160 mm room air horizontal termination kit (five plus water heaters)

Kit contains:

- Horizontal termination 160 mm
- Ø110-160 mm adapter

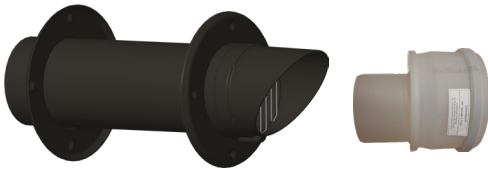

No image available

CFKOWT110: NB56kWi 110 mm outside air horizontal termination kit (four or less water heaters)

Kit contains:

- Horizontal termination 110 mm x2

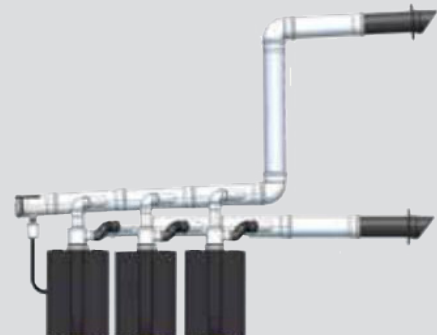
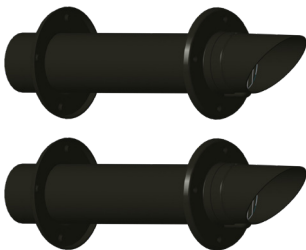

CFKOWT160: NB56kWi 160 mm outside air horizontal termination kit (five plus water heaters)

Kit contains:

- Horizontal termination 160 mm x2
- Ø110-160 mm adapter x2

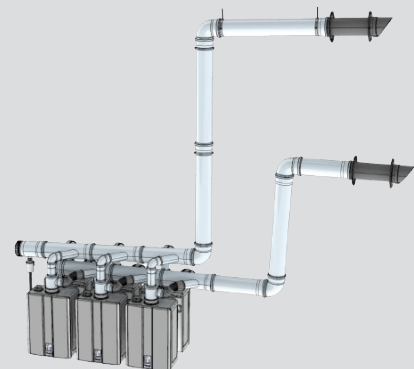
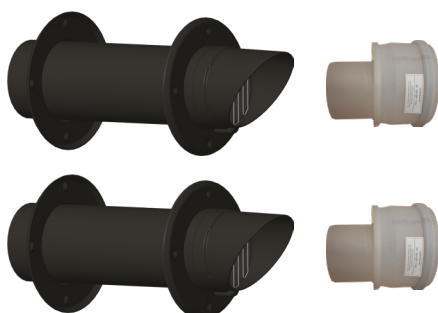

Component dimensions

Condensate trap (not available as a separate part*)

All starter kits will have the condensate trap as part of the kit. Comes with 1.2 m rubber hose (not pictured).

Dimensions:

- Overall length 101 mm
- Width 101 mm
- Height 187 mm



* **N.B:** Condensate trap is part of the starter kit.

Starter kit Ø110 mm CF790137 Starter kit Ø160 mm CF790138

Common to the room air and outside air starter kits and connects to the condensate trap.

Ø110 mm dimensions:

- Overall length 175.6 mm
- Height 249 mm
- Connected length 180 mm

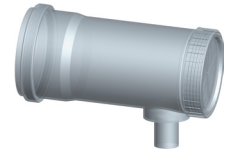

Collector 1-branch Ø110 mm CF005311 Collector 1-branch Ø160 mm CF005260

Part of the inline connection kits.

Ø110 mm dimensions:

- Overall length 586 mm
- Height 274 mm
- Connected length 520 mm

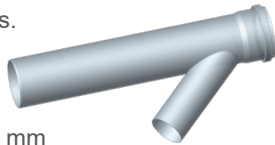

Collector 2-branch Ø110 mm CF005508 Collector 2-branch Ø160 mm CF005502

Part of the back-to-back connection kits.

Ø110 mm dimensions:

- Overall length 586 mm
- Height 451 mm
- Connected length 520 mm

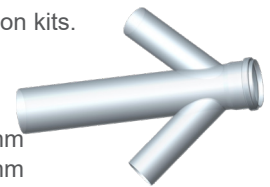

Bend 90° Ø80 mm CF222955

The 90° bend component is part of all the connection kits

Dimensions:

- Overall length 174 mm
- Height 183 mm
- Connected length N/A



Extension Ø80 mm 500 mm CF222951

Part of every connection kit. Each section requires cutting to achieve fall back to the condensate trap.

Dimensions:

- Overall length 500 mm
- Height 125 mm
- Connected length 440 mm



Room air adapter CF790145

For room air installations, one adapter needed for each water heater.

Dimensions:

- Overall length 130 mm
- Diameter 125 mm
- Height 125 mm
- Connected length 80 mm



Outside air adapter CF790144

For outside air installations, one adapter needed for each water heater. Comes with flex component.

Dimensions:

- Overall length 181 mm
- Diameter 125 mm
- Height 181 mm
- Connected length 131 mm



Wall terminal kit Ø110 mm CF790093

Horizontal wall terminal kit for installations with four or less water heaters

Dimensions:

- Overall length 640 mm
- Width 205 mm
- Height 205 mm
- Connected length 500 mm



Wall terminal kit Ø160 mm CF90094

Horizontal wall terminal kit for installations with five or more water heaters

Dimensions:

- Overall length 640 mm
- Width 205 mm
- Height 205 mm
- Connected length 500 mm



Vertical terminal Ø110 mm CF790095
Vertical terminal Ø160 mm CF790096

Termination for all vertical installations.

Ø160 mm dimensions:

- Overall length 281 mm
- Width 281 mm
- Height 1100 mm
- Connected length 1100 mm



Roof terminal ext kit metal 160mm CF790103

Part of vertical terminal kit, required to protect black plastic outer of terminal.

Dimensions:

- Overall length 1070 mm
- Diameter 200 mm



Exhaust rain cap Ø110 mm CF790097
Exhaust rain cap Ø160 mm CF790098

Metal cap that fits over the vertical terminal to stop excessive water from entering flue.

Dimensions:

- Overall length 281 mm
- Width 520 mm
- Height 520 mm



Intake rain cap Ø160 mm CF780061

Plastic helmet cap that sits over the intake vertical terminal to stop excessive water from entering the flue.

Dimensions:

- Overall length 195 mm
- Width 535 mm
- Height 535 mm



Flue pipe adapter Ø110-160 mm CF790085

Horizontal or vertical flue connection adapter for connecting 110 mm diameter to 160 mm diameter flue sections.

Dimensions:

- Overall length 186 mm
- Diameter 110-160 mm
- Height 186 mm
- Connected length 136 mm



Flue pipe Ø110 mm CF790028

110 mm diameter straight flue pipe sections.

Dimensions:

- Overall length 1000 mm
- Diameter 110 mm
- Height 110 mm
- Connected length 945 mm



Flue pipe Ø160 mm CF790089

110 mm diameter straight flue pipe sections.

Dimensions:

- Overall length 1000 mm
- Diameter 160 mm
- Height 160 mm
- Connected length 945 mm



45° bends Ø110 mm CF790026

Sold as a pair. 110 mm diameter bends for changing direction of flue.

Dimensions:

- Overall length 159 mm
- Diameter 110 mm
- Height 189 mm



45° bends Ø110 mm CF790026
45° bends Ø160 mm CF790086

Bends for changing direction of flue. Sold as a pair.

Dimensions:

- Overall length 159 / 220 mm
- Height 189 / 249 mm



90° bend Ø160 mm CF790087

Bend for connections and changing direction of flue.

Dimensions:

- Overall length 244 mm
- Diameter 160 mm
- Height 153 mm



Rinnai.co.nz

Tel: 0800 746 624

<http://www.youtube.com/rinnainz>

<http://facebook.com/rinnainz>

INFINITY NB56kWi common flue installation guide 13088-E