



Energysavers 309FT, 559FT, 561FT, 1005FT
Operation and installation guide

Rinnai

Important

Appliance must be installed with a Rinnai approved flue system.

This appliance must be installed in accordance with:

- Manufacturer's installation instructions
- Current AS/NZS 3000, AS/NZS 3500, AS/NZS 5601.1 and G12/AS1

For use with Natural Gas or Universal LPG as indicated on the appliance.

Appliance must be installed, commissioned and serviced by an authorised person, being in New Zealand a licensed gasfitter.

Please retain this manual for future reference.

Warning

Improper installation, adjustment, alteration, service and maintenance can cause property damage, personal injury or loss of life.

For more information about buying, using, and servicing of Rinnai appliances call: 0800 RINNAI (0800 746 624).

Rinnai New Zealand Limited
105 Pavilion Drive, Mangere, Auckland
PO Box 53177, Auckland Airport, Auckland 2150

Phone: (09) 257-3800
Fax: (09) 257-3899
Email: info@rinnai.co.nz
Web: rinnai.co.nz
[youtube.com/rinnainz](https://www.youtube.com/rinnainz)
[facebook.com/rinnainz](https://www.facebook.com/rinnainz)

Contents

About your Energysaver	4
Safety	6
Important	7
Setting the clock	8
Setting and operating the timers.....	9
Additional heater information.....	10
Care and maintenance	11
Troubleshooting	12
Error codes.....	13

Installation

Carton contents and item checklist.....	15
Energysaver specification summary.....	16
Energysaver dimension diagrams	17
Positioning, gas, and electrical supply.....	18
Energysaver flueing guidelines.....	19
Energysaver flueing options (most common)	20
Installation	21
Commissioning	23
Installation checklist.....	24
Installer details.....	24
Wiring diagrams.....	25
Limited Warranty	27

Gas appliances, like cars, require regular maintenance and servicing. For reliable operation Rinnai Energysavers, in residential applications, should be serviced **every two years**.

About your Energysaver

Congratulations on the purchase of your Rinnai Energysaver. Our high efficiency Energysaver range not only ensures a warm home, but a healthy home.

We hope you love this product as much as we do, and on the off chance that something does go wrong, or if you need help, we're only a phone call away.

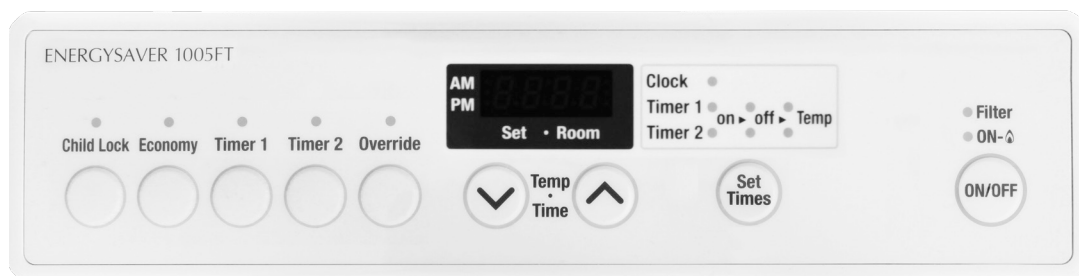

Features

Push button ignition	Only one-touch is required to turn the heater on and off
Child lock function	Prevents children from altering settings when the heater is in use or activating the heater when turned off
Preheat	Automatically functions in conjunction with the timers. When a timer is selected, the heater may operate anywhere within an hour prior to the programmed on time. The preheat function ensures the room reaches the desired temperature by the programmed start time.
Economy mode	Energy saving feature designed to control the room temperature and prevent the room from overheating
Override	Temporarily changes the heater operation from on to off, or off to on, until the next programmed setting is reached
Timer 1/Timer 2	Allows you to program the appliance to come on for two separate periods each day, one in the morning and one in the evening
Filter indicator	When the air (fan) filter becomes covered with dust the filter indicator will flash indicating that cleaning is necessary
Humidifier tray	Raise humidity in the room for extra comfort with the humidifier tray—can be filled with water as required

On/Off button

Main switch for turning the heater on and off. To turn on, press the ON/OFF button, the indicator will glow green, the spark generator will be heard before the burner ignites and the indicator will then glow red. When the heater warms up the fan will automatically start.

To turn the heater off, press the ON/OFF button, the indicator light will go out. The fan will continue to operate to cool the appliance and then stop.

Set times

Selects clock, timers, or temperatures (1005FT model only) for adjustment or programming.

Temp and time

Increases or decreases the temperature as well as changing the hours or minutes when in programming mode.

Override

Temporarily changes operation from ON to OFF or OFF to ON until the next programmed setting is reached.

Timer 1 and Timer 2

Displays which timer is operating.

Child lock

Locks all controls when pressed except OFF. Hold for two seconds to deactivate. If the child lock is pressed while the heater is off all functions will be locked, including turning the heater on, until it is deactivated.

Filter

Indicates the filter needs cleaning. If you do not clean the filter at regular intervals and the filter indicator is allowed to remain flashing, the appliance will stop and the display will show error code 14. The filter will need cleaning

before the appliance can be turned back on (refer p.11).

Clock and timer indicators

When programming, the indicators will glow to indicate what is being programmed.

The 1005FT model also has a 'Temp' indicator that indicates the set temperature for the timer that is being set.

Display window

Shows either the time of day, temperatures or coded error message.

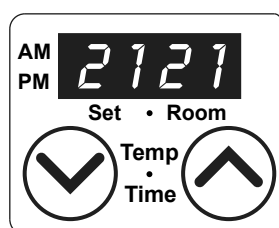

Please note: The temperature displayed is based on the appliance thermostat and could differ from the actual temperature of the room.

Adjusting the room temperature

Pressing the up and down arrows will change the preset temperature by 1 °C. The temperature will be shown in the display window. The room temperature sensor is located behind the Energysaver so the temperature on the display may vary slightly from the actual room temperature.

The temperature can be preset to:

L (low)

Typically used to keep the chill off a large room. The unit operates on the lowest burner setting until the inbuilt appliance thermostat senses the room temperature has reached approx. 14-16 °C*. At this point the burner will switch off, the fan will wind down, and the appliance will stop

heating. If the temperature then drops to below 10 °C the heater will switch back on.

* Factory preset temperatures—these cannot be changed

16-26 °C

Unit will modulate, and in some instances turn off and on, to maintain the selected temperature.

H (high)

Unit operates on the highest burner setting.

The 'L' and 'H' settings are not normally used as it means the heater operates without a set temperature.

Economy

Prevents the room overheating, reduces gas consumption, and ultimately saves energy. Once the room has reached the desired temperature, the unit automatically begins gradually reducing the set temperature (set temperature on digital display will stay the same). This reduction is normally not noticeable.

How it works

After the room reaches the set temperature, the set temperature will automatically start decreasing, dropping by a maximum of 1 °C in 30 minute blocks, until comfort control is reached. When in comfort control the unit alters combustion and fan speed to keep the room at a comfortable temperature.

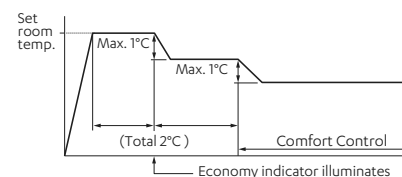

The 'Economy' function will not operate when the set temperature is less than 16 °C or above 26 °C.

Safety

- Not to be connected to an LPG gas cylinder located indoors
- Do not place articles on or against this appliance
- Do not use or store flammable materials near this appliance
- Do not modify this appliance
- Do not spray aerosols in the vicinity of this appliance while it is operating

This appliance is not intended for use by persons (including children) with reduced physical, sensory or mental capabilities, or lack of experience and knowledge, unless they have been given supervision or instructions concerning the use of this appliance by a person responsible for their safety.

The power point must be to the side of the heater. It must not be above the unit as this is a potential fire hazard.

Do not restrict the warm air discharge by placing articles in front of the heater. This appliance must not be used for any purpose other than heating.

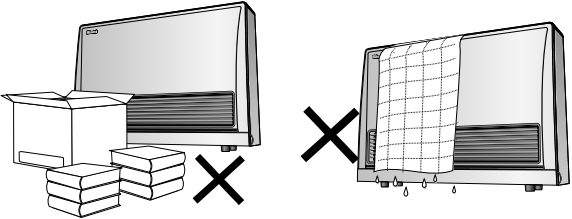

Do not allow anyone to post articles through the louvres, or let flammable and combustible materials to come into contact with the heater. Do not place articles on or against the heater.

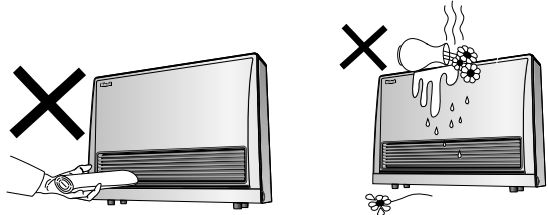

Do not spray aerosols while the appliance is operating. Most contain butane gas which can be a fire hazard if used near the appliance. Do not use or store flammable materials near this appliance. Combustible materials must not be placed where the heater could ignite them.

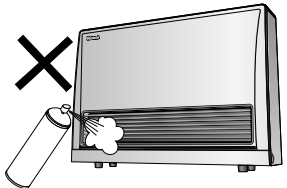

Children should be supervised at all times to ensure they do not play with the heater. Hand or body contact with the heater must be avoided, especially with the louvres, which can become very hot. Do not allow anyone to sit, lean or sleep directly in front of the heater.

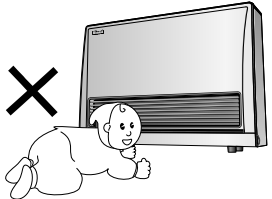

A dedicated 230 V 10 A power point must be used with this heater. Do not use double adaptors to operate this appliance.

Do not unplug the heater while it is still in use or while the fan is on.

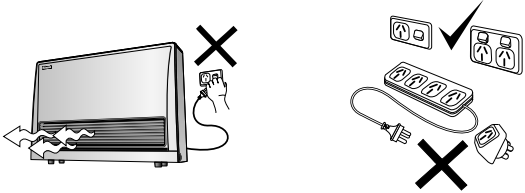

When the heater is used for the first time or after long periods of not being used, a slight odour may be emitted—this is normal. If odours persist turn the appliance off and contact Rinnai.

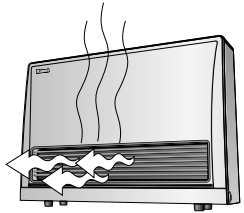

Important

Clearances while the heater is operating

This appliance must not be installed where curtains or other combustible materials could come into contact with it. In some cases curtains may need restraining.

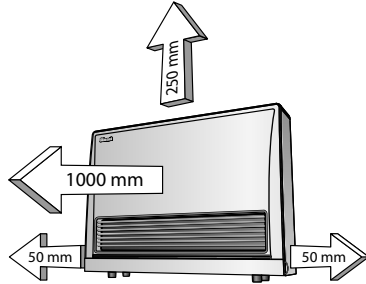

Floor protection

Energysavers discharge a large volume of warm air at a low level. Heat over time may affect the appearance of some flooring materials, such as, carpet, vinyl, cork, or timber. This may be amplified if the air contains cooking vapours or cigarette smoke. To avoid this occurring, it is recommended that a mat be placed in front of the appliance.

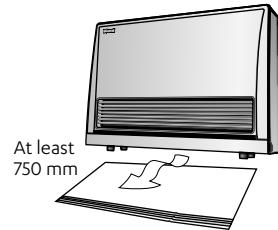

Outside flue terminal 1

Keep flammable materials, trees, shrubs, etc. away from the flue terminal. In areas subject to heavy snowfall, keep snow clear of the flue terminal at all times.

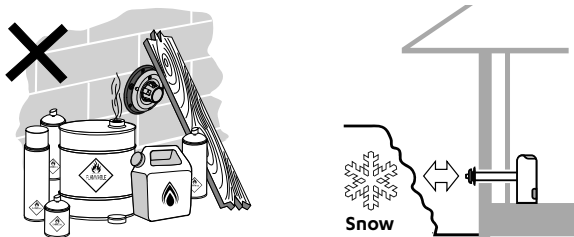

Outside flue terminal 2

On cold days steam may be discharged from the flue terminal. This is normal with high efficiency gas appliances like the Energysaver range and does not indicate a fault.



Filters

During peak operating periods the filters should be cleaned weekly. If the 'Filter' warning indicator flashes on the control panel display, immediately turn off the appliance and clean filters before starting again.

○ Filter

○ ON-💧



Humidifier tray

Do not overfill—there is a maximum water level indicator in the tray. Also do not fill while the heater is operating, more information on p.10.



The Energysavers must not be built into bookcases or walls etc.



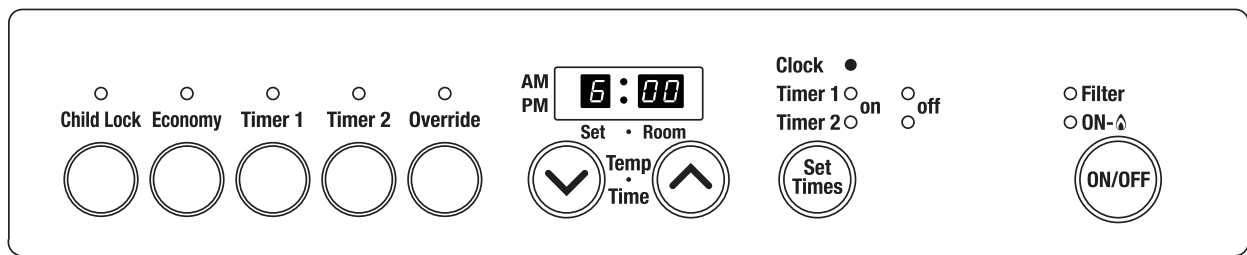

Energysavers are not recommended for installations in unusually dusty environments such as hair salons or where there are a large number of pets—this will cause continual blockage of the filter(s).

Setting the clock



When the appliance is first plugged in or after a power failure the digital display will show --: --.

Setting the clock (example: setting the clock to 10:35 am)

1. Press the Set Times button once, the clock indicator will flash.
2. Press and hold the  button, the minutes will change first followed by the hours.
3. Release the  button when the AM 10:00 shows in the digital display. Confirm that you have selected AM, a small indicator on the left hand side of the digital display indicates the AM setting.
4. Press and hold the  button again and release when the display shows AM 10:35. If you go past the time you can use the  button to change the time setting in reverse.
5. Press the Set Times button five times (seven times for the 1005FT) to lock in the set time. The Clock and Timer indicators will go out and a small indicator on the display will flash to show the clock is operating. The display will dim approximately 10 seconds after the last button is pressed.

Digital display

The digital display is turned off when the appliance is turned OFF.

Daylight saving

Follow steps 1-5 to adjust for daylight saving and anytime the clock needs to be adjusted.

Setting and operating the timers

Before operating the timers the clock must be set and a timer start and finish time must be entered. The timers can be programmed to operate for any two time periods in 24 hours. The programmed time must be selected and locked-in within one minute of the timer indicators flashing otherwise the programmed times will not be retained in the system memory.

The 1005FT model when setting the timers also requires a temperature to be set.

Don't worry if you make a mistake during programming. By pressing the Set Times button you can cycle through the different programming options (clocks and timers) and change if required.

▲ = up button

▼ = down button

Setting the timers RHFE-309FT, 559FT, 561FT

Example, program Timer 1 to heat the room by 7:10 am and finish at 9:00 am.

1. Press the Set Times button twice. The digital display will show AM 6:00 and the Timer 1 indicator will flash. Press the up or down button until AM 7:00 appears, release, then press the up or down button again until AM 7:10 appears.
2. Press the Set Times button again, the Timer 1 OFF indicator will flash. Press the up or down button until AM 9:00 appears.
3. Press the Set Button three times to lock in the programmed time. The digital display will show the current time.

Timer 2 is programmed in the same way—remember to ensure that the Timer 2 indicator is flashing before you start programming.

Setting the timers 1005FT

Example, program Timer 1 to heat the room by 7:10 am and finish at 9:00 am at a temperature of 18 °C.

1. Press the Set Times button twice. The digital display will show AM 6:00 and the Timer 1 indicator will flash. Press the up or down button until AM 7:00 appears, release, then press the up or down button again until AM 7:10 appears.
2. Press the Set Times button again, the Timer 1 OFF indicator will flash. Press the up or down button until AM 9:00 appears.
3. Press the Set Times button again, the Timer 1 Temp indicator will flash. Press the up or down button until 18 appears.
4. Press the Set Button four times to lock in the programmed time. The digital display will show the current time.

Timer 2 is programmed in the same way—remember to ensure that the Timer 2 indicator is flashing before you start programming.

Operating the timers

1. Press the ON/OFF button (ensure the clock and timer indicators are not flashing), the ON indicator will glow green.
2. For the RHFE-309FT, 559FT, and 561FT, using the up and down buttons, select the desired temperature setting.
3. Press the Timer 1 and/or Timer 2 button(s). The timer indicator(s) will glow and the heater will remain on standby until the timer setting is reached—timer indicator will flash and the heater will turn on.

Additional heater information

Humidifier tray

Your heater is fitted with an enamel humidifier tray. To fill the tray, open the access panel as shown in the diagrams below. Pour water into the tray, or in the case of the 1005FT, pour water into the filler spout built into the access panel.

RHFE-309FT / 559FT/561FT

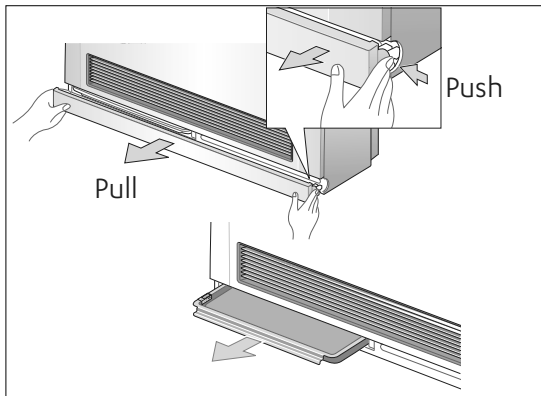

RHFE-1005FT

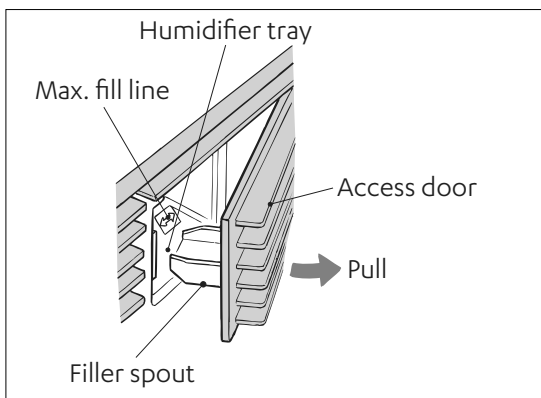

If you notice water in the humidifier tray, but you have not placed any in there do not be alarmed, this is normal. This will be condensate from the flue system—designed to drain into the humidifier tray.

If you are using the humidifier tray, it will need filling approximately once a day.

- Do not fill the humidifier tray while the heater is on, it will be very hot and could cause burns—turn the heater off and wait at least five minutes.
- Do not operate the heater without the humidifier tray in place.

Vertical louvre adjustment

When the heater is turned off the warm air flow direction may be altered by carefully inserting a screwdriver or similar tool and gently bending the vertical louvres to the left or right.

The louvres are not designed to be adjusted more than six times as they will weaken and break.

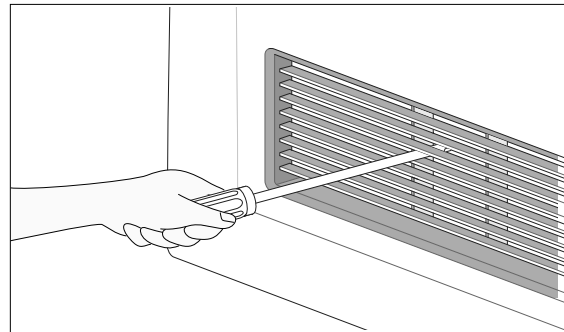

Power failure

If a power failure occurs for at least 0.2 seconds the unit will turn itself off. After power has been restored the unit will automatically turn on again—you may need to reset the clock depending on the length of the power cut.

If timer settings have been programmed the system memory will retain the timer settings, but the clock will stop at the time the power goes off and will be slow by however long the power has been off.

Preheat

Automatically functions in conjunction with the timers. When a timer is selected, the heater may operate anywhere within an hour prior to the programmed on time. The preheat function ensures the room reaches the desired temperature by the programmed start time.

Care and maintenance

Before cleaning any part of the heater ensure it is turned off and has cooled down. All parts of the heater can be cleaned using a soft damp cloth and mild detergent—do not use solvents.

If the humidifier tray gets dirty it can be washed in warm soapy water.

Fan filter(s)

To protect the appliance from dust or lint a filter (two in the case of the 1005FT) is located at the rear of the appliance. If the filter becomes blocked the filter indicator will flash to indicate that it should be cleaned.

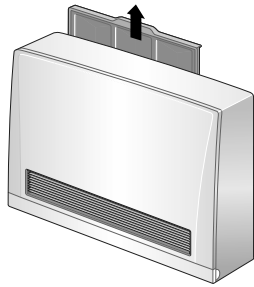

The build up of dust on the filter reduces the air flow through the heater. This reduces the heater's efficiency and can lead to the appliance shutting down. Regular (weekly) filter cleaning during the heating season will stop this from happening.

If you do not clean the filter at regular intervals and the 'Filter' indicator is allowed to remain flashing, the appliance will stop (ON indicator will flash and the display will show error code 14). The filter will need to be cleaned before operating the appliance again.

- Do not remove the filter when the appliance is operating.
- Do not use the heater with the 'Filter' indicator flashing as this may cause the appliance to overheat.

Cleaning the fan filter(s)

- Dry dust/lint: Use a duster or vacuum to remove the dust.
- Oily residue: Wash using a mild detergent, drain off the water, and dry.



Ensure the fan filter is fitted back into the appliance after cleaning. **DO NOT** operate the appliance without the filter in place.

Maintenance and servicing

Rinnai has a maintenance, service and spare parts network with personnel who are fully trained and equipped to give the best advice on your Rinnai appliance. If your appliance needs maintenance or servicing for repair, please call Rinnai (0800 746 624).



For reliable operation your Rinnai Energysaver, including inspection of the flue section, should be checked by a licensed tradesperson every two years. If located in a particularly dusty area or subject to excess lint, for example dog hair or where there are newly laid carpets, then annual servicing would be beneficial.

Regular maintenance and servicing is not covered by the Rinnai warranty.

If you have any other faults or problems, please contact your installer or call Rinnai.

Troubleshooting

Check the following information before making a service call. If you are still unsure or concerned after reading this section, please contact Rinnai.

Using the heater for the first time, or after a long period of non use

The heater may not start the first time it is operated due to air in the gas pipes. If ignition does not occur within approximately one minute the heater will attempt to start again. If it does not start the unit will switch itself off automatically—this is a safety feature. Try switching the heater back on if this occurs.

What's happening	Explanation and/or possible solution
Warm air not coming from the heater when it starts.	The heater's fan will start automatically after a short delay. This is to allow the appliance to warm up and to stop cold draughts.
Smoke or strange smells coming from the heater after it has been installed.	This is caused by grease, oil, or dust within the appliance. It will stop after a short time.
Clicking noises when the heater starts or stops, or changes to a higher or lower setting.	This is the expansion and contraction of the heat exchanger and is a normal part of operation.
Clunking noise when the thermostat operates.	This is the sound of the gas valve opening and closing to regulate the flow of gas and is a normal part of operation.
Fan continues to run after the heater is turned off.	This is to remove the heat from the appliance and will stop once the heater has cooled down.
Timer(s) do not operate at the set time.	Check the timers are set correctly as they may be inactivated or incorrectly programmed.
Smell of gas.	There may be a small leak in the appliance. Turn the heater off and contact Rinnai.
Heater doesn't start.	Check power cord is plugged in properly. Check the child lock isn't on.

Error codes

The Energysaver range has built-in technology to continually monitor its own performance. If a fault occurs an error message will flash on the digital display on the control panel. This assists with diagnosing the fault and may enable you to overcome a problem without a service call.

In all cases you may be able to clear the error by turning the heater off and on again. If the error code remains or returns when the heater is used again, contact Rinnai.

Faults caused by insufficient gas supply, gas quality, installation or operation errors are not covered by the Rinnai warranty.

Error code	Likely cause	Suggested solution
11	Ignition failure	Check gas supply is turned on, turn the heater OFF then ON again. If the error persists a service call is required.
12	Flame failure	As above.
14	Filterblockage/overheat	Clean filter(s), if the error continues a service call is required.
16	Room overheat*	Lower the room temperature below 40 °C
30	Overheat temperature sensor faulty	Service call.
31-32	Room temperature sensor faulty	Service call.
33-35	Overheat temperature sensor faulty	Service call.
53	Spark sensor faulty	Service call.
61	Combustion fan faulty	Service call.
62	Convection fan faulty	Service call.
70	Faulty ON/OFF switch	Service call.
71	Faulty solenoids	Service call.
72	Flame detection circuit fault	Service call.
73	Communication error	Service call.
81	Faulty solenoids	Service call.

* If the unit detects 40 °C for over ten minutes, the unit will stop operating.

Installation

Installation, servicing and repair shall be carried out only by authorised personnel.

Carton contents and item checklist

Unpacking the appliance

The heater is supplied in one carton containing the heater, standard rear panel set and screw pack. Remove all packaging materials and check for damage. If any damage is evident do not install or operate the appliance—contact your place of purchase for advice.

Before installing the heater, check it is labelled for the correct gas type. Refer to the data label at the rear of the heater.

The heater does not come supplied with flue components. These are purchased separately. Only Rinnai Energysaver flue components can be used with this appliance.

Carton contents and item checklist, check you have:

- One of the following Rinnai Energysaver heaters
 - RHFE-309FT - RHFE-559FT
 - RHFE-561FT - RHFE-1005FT
- One rear panel set comprising of left, right, and top panel cover panels
- One pack containing the following

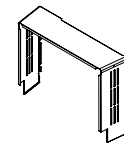
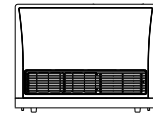

Part		RHFE-1005FT	RHFE-309FT/559
Plastic inlet hose clips (holds the air intake hose in place)		0	2
Air intake baffle ring* (ensures the max. efficiency of the heater, p.21)		0	1 (309, 559 models only)
Stainless steel sheath clamp (holds the protective sock on the exhaust pipe in place)		1	1
Securing bracket (secures the heater to the wall, p.212)		2	2
150 mm cable tie (secures the air inlet elbow onto the flue)		1	1
Flue lock clamp (secures the exhaust pipe assembly onto the flue)		1 - large 1 - small	1 - small
Screw hardware pack		1	1

* The air intake baffle ring is only required to be installed on the 309 and 559 models, which use the ESDFK component in a direct flue installation.

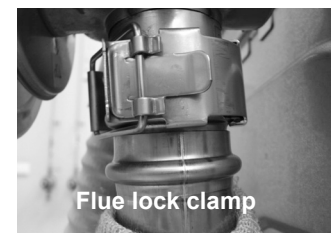
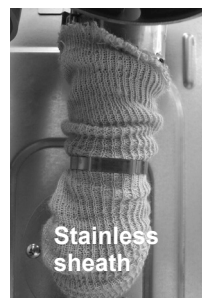
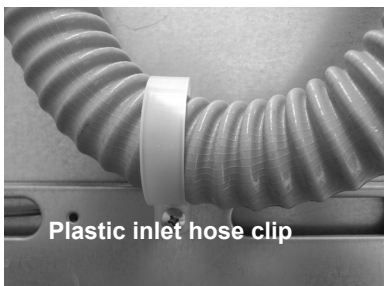

Energysaver specification summary

	Energysaver 309FT	Energysaver 561FT	Energysaver 559FT	Energysaver 1005FT
Colour	White with grey louvres	White with grey louvres	White with grey louvres	White with grey louvres
Data plate	Lower right hand side	Lower right hand side	Lower right hand side	Lower right hand side
Efficiency*	82.9%	82.7%	83.3%	83.5%
Energy star rating	4.8 star energy equivalent	4.8 star energy equivalent	4.8 star energy equivalent	4.8 star energy equivalent
Remote switch	Yes**	Yes**	Yes**	Yes**
Gas connection	15 mm BSP male thread	15 mm BSP male thread	15 mm BSP male thread	15 mm BSP male thread
Input*	5.8-13 MJ/h	9-23 MJ/h	9-23 MJ/h	15.5-37 MJ/h
Output*	1.2-3.1 kW	1.9-4.9 kW	1.9-5.3 kW	2.3-8.8 kW
Humidifier tray capacity	0.8 L	1.0 L	1.0 L	3.0 L
Injectors (mm) NG	2 x 1.25 Ø	4 x 1.25 Ø	4 x 1.25 Ø	4 x 1.25 Ø 1 x 0.45 Ø
Injectors (mm) ULPG	2 x 0.85 Ø	4 x 0.82 Ø	4 x 0.82 Ø	4 x 1.00 Ø 1 x 0.30 Ø
Noise level	31-38 dB(A)	34-42 dB(A)	33-42 dB(A)	39-45 dB(A)
Power consumption	Approx. 41 W (high) <1 W on standby	Approx. 90 W (high) <1 W on standby	Approx. 50 W (high) <1 W on standby	Approx. 123 W (high) <1 W on standby
Temperature range	16-26 °C	16-26 °C	16-26 °C	16-26 °C
Weight	21 kg	25 kg	26 kg	42 kg
Additional features	Common to all Energysavers: Preheat function, dual timers, manual control, electronic ignition, economy mode, air filter, overheat safety device, and child lock			

* Will vary depending on gas type and flue length

** Remote switching kit R1349

For gas pressure and gas type refer to the data plate on the lower right hand side of the appliance.

Energysaver dimension diagrams

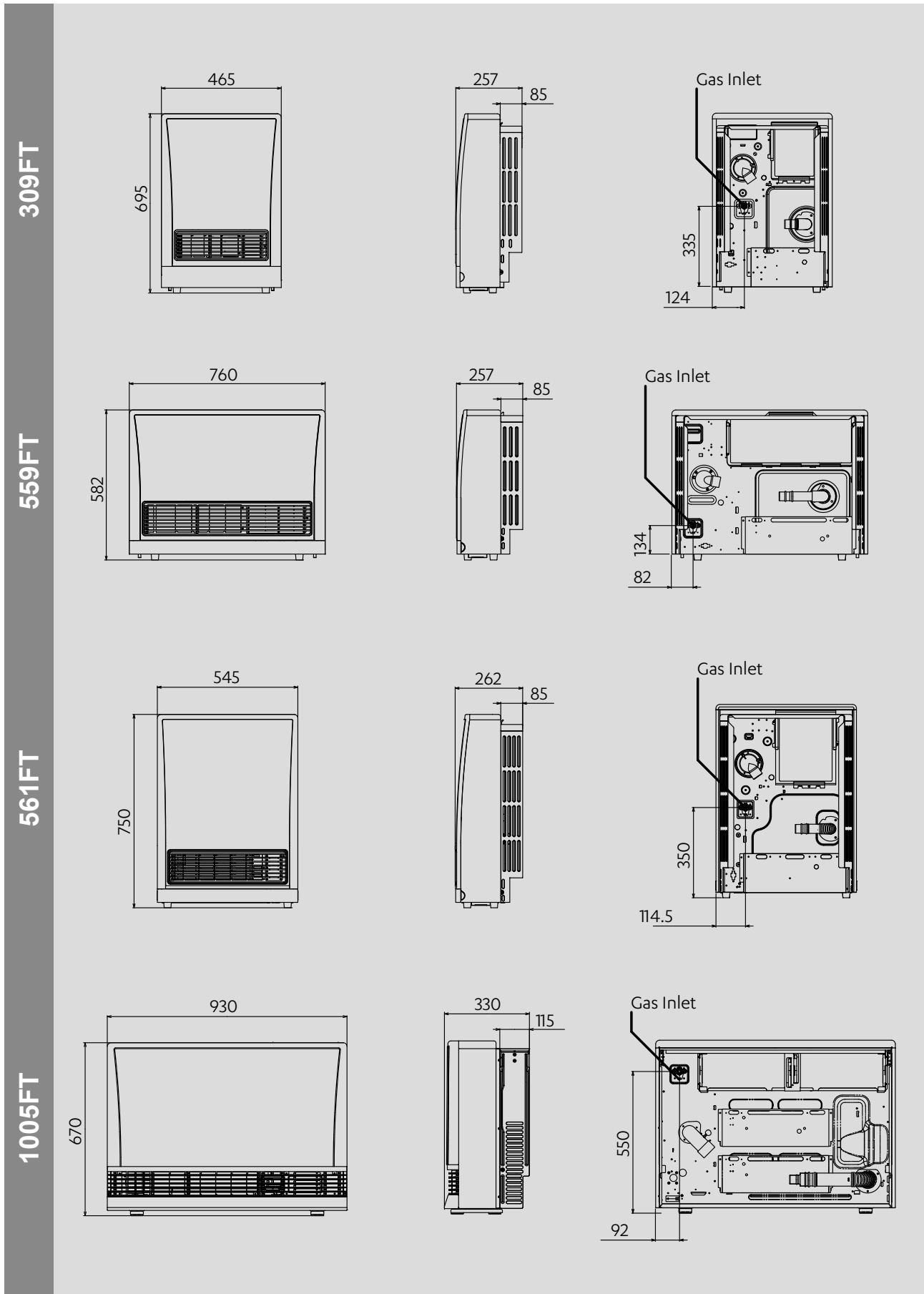

Positioning, gas, and electrical supply

Positioning

The main points governing the location of the heater are flueing and warm air distribution. The heater must not be installed where curtains or other combustible materials could come into contact with the appliance. In some cases curtains may need restraining—refer p. 7 for clearance information.

This heater is not recommended for installations in unusually dusty environments such as hair salons or where there are a large number of pets—will cause continual blockage of the fan filter.

Gas supply

The gas supply terminates outside the heater at the rear of the appliance. The gap required between the wall and heater body is 85 mm for the standard rear panels (115 mm for the 1005FT) or 200 mm for the back spacer kit.

Gas piping must consider the gas input to this appliance as well as other gas appliances in the building. An approved sizing chart such as the one in AS/NZS 5601.1:2013 should be used.

All foreign materials such as filings must be purged from the gas supply as they may cause the gas control valve to malfunction.

Electrical supply

The electrical connection is to the right hand side of the heater (passes out of the rear of the appliance). A 3-pin plug with a 1500 mm power cord is supplied, this must be connected to a dedicated earthed power point. The power point must not be above the unit as this is a potential fire hazard.

Alternatively the appliance can be direct wired if the power supply is to be concealed. The electric isolation switch **MUST BE** accessible after the appliance has been installed. Consult a qualified electrician if direct wiring is required as it must comply with the requirement of AS/NZS 5601.1:2013 and AS/NZS 3000 and any other relevant local regulations.

If the supply cord is damaged and requires replacing, it must be replaced by a licensed tradesperson. This must be a genuine replacement part available from Rinnai.

Energysaver flueing guidelines

Every Energysaver heater requires a flue system that will draw effectively and clear products safely under all potential wind and climatic conditions.

It is the responsibility of the installer to ensure that the appliance is provided with an effective flue. Some guidelines to assist with flue design are listed below. These must be read and modified as necessary with reference to the particular installation.

All Rinnai Energysavers must be installed with an approved Rinnai Energysaver flue system. Approved flue components are detailed in this guide.

Clearance to combustibles

All Energysaver flueing components have zero clearance EXCEPT for the elbow section of the ESKIT03, and ESELBOWB. These components require a minimum clearance of 25 mm from combustible materials.

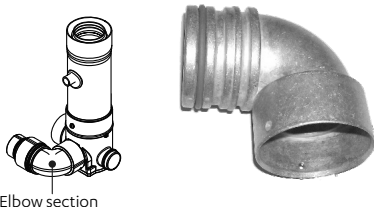

Condensate trap

A condensate trap is required for all vertical installations to ensure condensate generated during combustion is trapped and prevented from entering the chamber of the heater.

2° fall to wall terminal

For direct, sideways, and down-and-out installations, there must be a continuous fall of at least 2° to the wall terminal (equates to 20 mm per metre). The Energysaver AA/A direct mushroom flue

kits have an inbuilt 2° fall, and the wall plate of the ESDFK kit has a 2° offset.

Flue terminal locations

Must be compliant with AS/NZS 5601.1:2013.

- Do not flue into natural draught flues or fireplaces.
- Do not flue into other rooms, roof spaces, or under floor spaces.

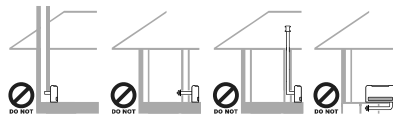

Flue terminal must be positioned away from flammable materials.

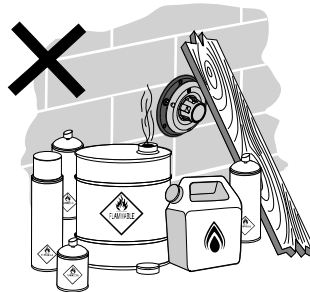

In areas subject to heavy snowfall, keep snow clear of the flue terminal at all times.

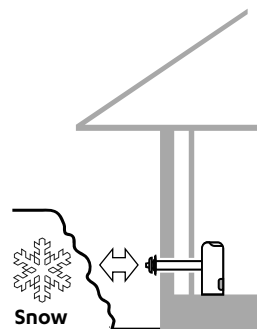

Flashings

Flashings are not part of the flue kit and must be specified.

Vertical terminations: Flue cowl clearance

To ensure products of combustion are cleared, adequate clearance from the building is required.

The flue cowl should have a 500 mm clearance from any part of the building. This also applies to steeped and pitched roofs which should be clear of the ridge line. Lesser clearances may provide perfectly adequate flue systems depending on the installation. Minimum clearances are shown in AS/NZS 5601.1:2013.

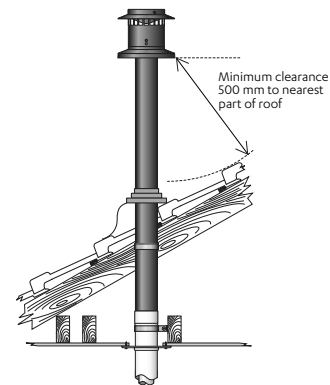

Maximum flue length and number of bends

Max. flue length = 9 m
Max. number of bends = 3

One 90° bend equals 1 m. For every 90° bend the overall length must be reduced by 1 m. For example, if an installation has three 90° bends, the maximum flue length can be 6 m.

The flue transition connection for the ESKIT03 and ESELBOWB is counted as a 90° bend.

Energysaver flueing options (most common)

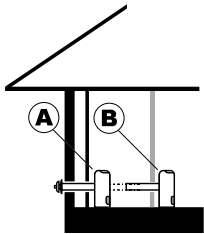
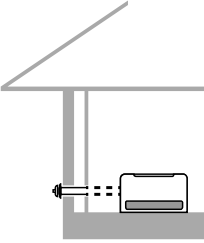
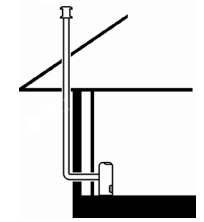
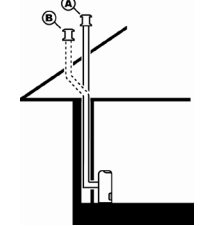
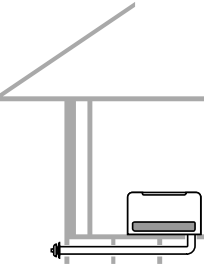
Flueing option	Description	Flue components
Direct and direct extended flueing		
	<p>Direct through-wall flueing for walls 75-385 mm thick.</p> <p>Flue can be extended if wall thickness is greater than 385 mm using the ESDFK and additional lengths of ESPIPE900.</p>	<p>A - Direct</p> <ul style="list-style-type: none"> R1350, mushroom flue kit for walls 75-115 mm R1351, mushroom flue kit for walls 115-240 mm ESDFK¹, straight horiz. kit for walls up to 385 mm <p>B - Direct extended ESDFK¹ + ESPIPE900²</p>
Sideways extension flueing		
	<p>Flue runs along the left or right hand side of an internal wall behind the heater.</p> <p>If retrofitting the flue can be boxed in along the floor or behind a 125 mm false wall. The installation requires additional clearance off the wall, a back spacer kit is required.</p>	<p>Sideways in-wall ESDFK¹ + ESELBOWB + ESPIPE900²</p> <p>Sideways front-of-wall Back spacer kit + ESDFK¹ + ESPIPE900²</p>
Vertical extension through-wall flueing		
	<p>Flue runs directly from the appliance to a vertical termination on the roof. Typical installation examples for this flue configuration is for Energysavers installed against solid brick walls, or where there are flue clearance restrictions.</p>	<p>Vertical termination ESDFK + ESBEND³ + ESPIPE900² + ESCONDK + ESROOFCOWL</p>
Vertical extension in-wall flueing		
	<p>Flue is installed within a stud wall (min. cavity depth 90 mm) and is run vertically. This type of installation is usually completed at the framing stage.</p>	<p>A - Direct ESKIT03 + ESPIPE900² + ESROOFCOWL</p> <p>B - Offset ESKIT03 + ESPIPE900² + ESBEND³ x 2 + ESROOFCOWL</p>
Down and out flueing		
	<p>Flue runs below the floor to an external termination—must have a continuous fall of 2° to the termination point to drain condensate. Ideal for Energysavers that need to be located in a central position of a building.</p> <p>If not going in-wall the flue will require additional clearance of the wall—back spacer kit required.</p>	<p>Down and out Back spacer kit + ESDFK¹ + ESPIPE900² + ESBEND³</p> <p>Down and out in-wall ESELBOWB + ESDFK¹ + ESBEND³ + ESPIPE900²</p> <p>Down and out through-wall⁴ ESDFK¹ + ESBEND³ x 2 + ESPIPE900²</p>

¹ Use terminal off ESDFK on outside wall

² ESPIPE900, order lengths as required

³ ESBEND kit contains 2 x 45° bends

⁴ Installation that goes out to another room and then down and out

Installation

Connecting the heater to the gas pipe

1. Remove the plastic protection cap from the threaded gas inlet located at the rear of the appliance.
2. Position the appliance gas inlet in line with the gas supply.
3. Attach the gas supply pipe to the appliance gas inlet and tighten (finger tight).



Mark the flue position

1. On the wall behind the appliance mark the vertical line of the heater, centreline.
2. Mark the flue penetration according to the instructions in the Energysaver flue installation manual. Undo the gas connection and remove the heater, and cut the flue penetration (wall penetration example shown below).

Attach securing wall brackets

Mark the securing bracket screw holes using the heater centreline as reference. For example, the 309FT is 465 mm wide so the centreline will be 232.5 mm. Measurement 'A' is 250 mm, which will be 125 mm either side of the centreline.

Model	A	B
309FT	250 mm (125 mm either side of centreline)	630 mm
559FT	350 mm (175 mm either side of centreline)	537 mm
561FT	280 mm (140 mm either side of centreline)	688 mm
1005FT	875 mm (437.5 mm either side of centreline)	622 mm

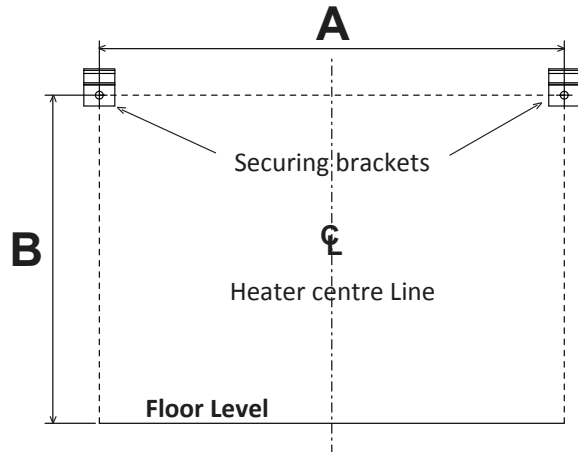

Attach the two securing brackets supplied to the wall using the two 8 g x 30 mm screws supplied or suitable equivalent.

Baffle ring installation

For 309FT/559FT installations using the ESDFK direct flue

To ensure maximum efficiency of the appliance a baffle ring is required to be installed for the 309FT and 559FT heaters that use the ESDFK in a direct flue installation (refer A: Direct flueing on previous page).

1. Unscrew the air intake elbow from the air intake hose (left handed thread, clockwise to undo).
2. Insert the air intake baffle ring into the appliance end of the air intake elbow.
3. Screw the air intake hose back into the air intake elbow, ensuring that the air intake baffle ring is seated flush against the end of the air intake hose.

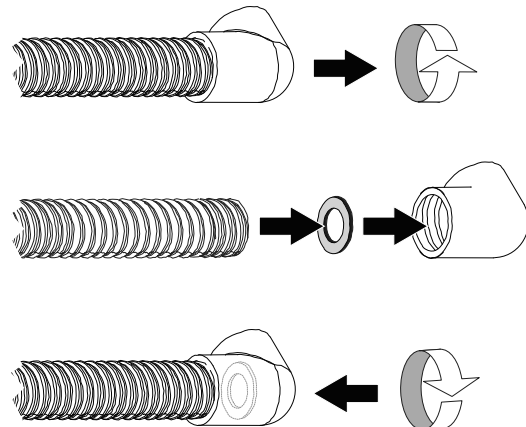

Installation continued

Install flue

1. Install the flue as per the instructions in the Energysaver flue installation manual.
2. Return the Energysaver to its final position and connect to the flue.
3. Connect gas supply line and fully tighten connection. Use a soapy solution to test all gas connections. If a leak is present bubbles will form at the leak point. When finished remove any residue with a rag. Prevent any soapy solution from coming into contact with the electrical components.

Fit the rear panels

The rear panels are NOT an optional component and MUST BE fitted to ensure the correct and safe operation of the appliance while also providing concealment and protection of the flue and gas connections. Failure to fit the panels will void any warranty.

1. Fit the left and right cover panels to the rear of the appliance by clipping the panels onto the location tabs, then fastening into position using the two 6 g x 8 mm self tapping screws. These screws located into the pre-drilled and formed recesses of the panels and appliance. N.B: The 1005FT model, in addition to the above step, also requires securing into the two side panel brackets, refer image below.

Side rear panels 309, 559, 561FT

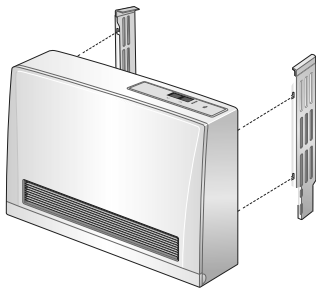

Side rear panels 1005FT

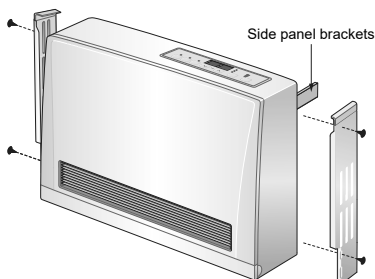

2. Remove the fan filter(s).
3. Carefully fit the top cover panel ensuring the rear fold locates neatly between the two securing brackets and the wall. Secure the top cover panel with the 6 g x 8 mm pan head screws supplied (2 for the 309, 559, 561FT, and 3 for the 1005FT).

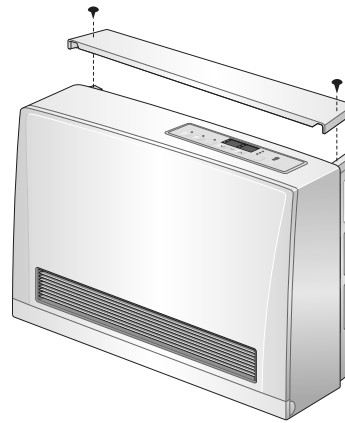

4. Replace the filter(s).

Commissioning

For commissioning instructions refer to the Commissioning sheet attached to the front panel of this appliance.

Ensure you leave this guide and the completed installation checklist with the customer. Explain to the customer about the use and care of the unit and that they understand the instructions and operation of the heater.

It is the responsibility of the installer to check that all the flue gases are exhausted to the atmosphere and that there is no spillage of combustion gases into the room.

If the appliance cannot be made to perform correctly, please contact Rinnai.

Burning in period

Advise the customer that during the initial burning in period of approximately two hours some vapour and smell may be emitted from the heater—this is normal. During this burning in period the heater should be operated on High, ensure the space being heated is well ventilated.

Installation checklist

The installer must complete the installation checklist below and make sure the guide is left with the homeowner. They must also instruct the homeowner about the use and care of the appliance and ensure understanding of the safety instructions.

Checklist

- Appliance positioned in a suitable location with required clearances
- All packaging and protective materials removed prior to operation
- Appliance test point pressure correct for the installation, and flue configuration adjusted if necessary

- Only Rinnai Energysaver flue components used
- Air inlet hose and flue connections secure
- Heater secured to the wall
- Gas connection correct and gas supply pipe purge of foreign matter before connection
- Appliance inlet pressure correct with all other gas appliances operating
- Where applicable condensate hose has been connected
- Flue clearances and installation as per current AS/NZS 5601.1
- Customer advised to service the heater every two years

Installer details

Company name:

Installer name:

Address:

Phone:

Mobile:

Certificate of compliance number for installation:

Signed:

Date:

Wiring diagrams

RHFE-309FT / 559FT

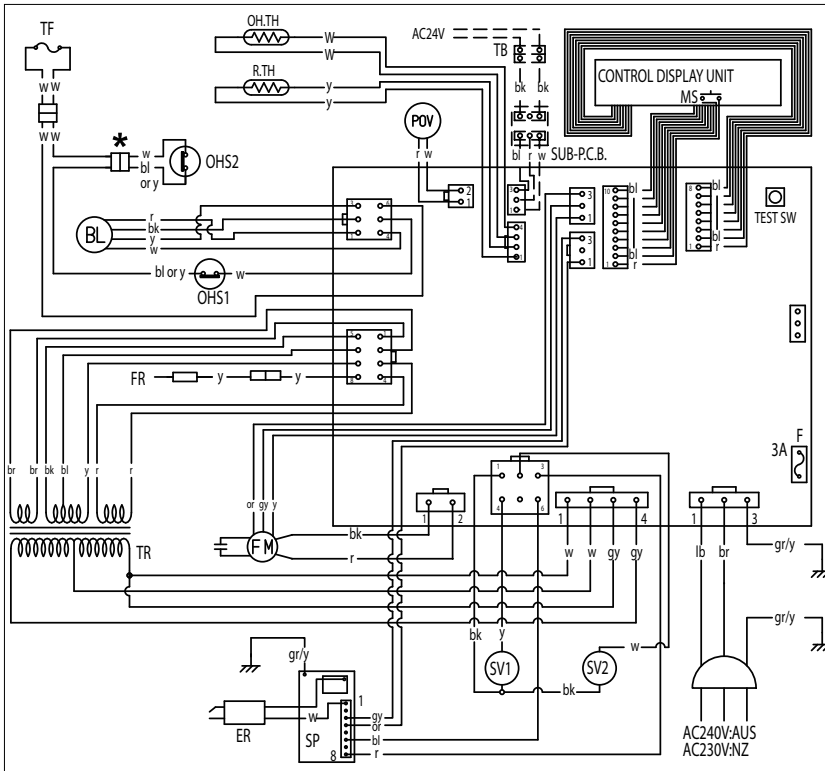

MARK	PARTS NAME
MS	MAIN SWITCH
R.TH	THERMISTOR
TF	THERMAL FUSE
F	FUSE
ER	ELECTRODE
POV	MODULATING SOLENOID VALVE
TR	TRANSFORMER
TB	TERMINAL BLOCK
OH.TH	OVER HEAT THERMISTOR
OHS1,2	OVER HEAT SWITCH1,2
FM	CONVECTION FAN MOTOR
SP	SPARKER
SV1,2	MAIN SOLENOID VALVE 1,2
BL	COMBUSTION FAN MOTOR
FR	FLAME ROD

CODE	COLOR	CODE	COLOR
bk	black	w	white
bl	blue	y	yellow
lb	light blue	gy	gray
gr/y	green/yellow	or	orange
r	red	br	brown

RHFE-561FT

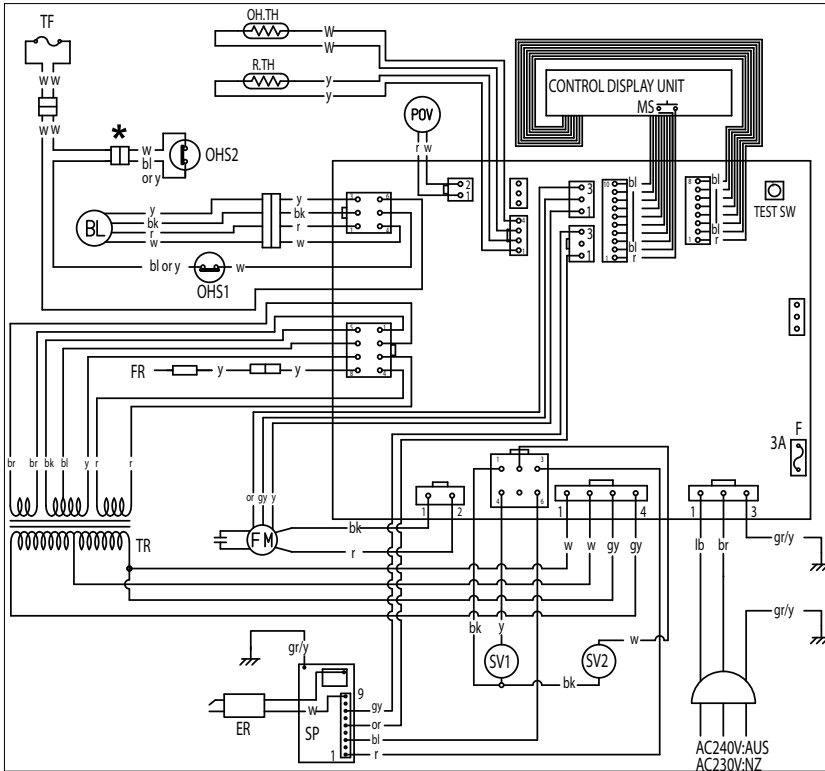

MARK	PARTS NAME
MS	MAIN SWITCH
R.TH	THERMISTOR
TF	THERMAL FUSE
F	FUSE
ER	ELECTRODE
POV	MODULATING SOLENOID VALVE
TR	TRANSFORMER
TB	TERMINAL BLOCK
OH.TH	OVER HEAT THERMISTOR
OHS1,2	OVER HEAT SWITCH1,2
FM	CONVECTION FAN MOTOR
SP	SPARKER
SV1,2	MAIN SOLENOID VALVE 1,2
BL	COMBUSTION FAN MOTOR
FR	FLAME ROD

CODE	COLOR	CODE	COLOR
bk	black	w	white
bl	blue	y	yellow
lb	light blue	gy	gray
gr/y	green/yellow	or	orange
r	red	br	brown

RHFE-1005FT

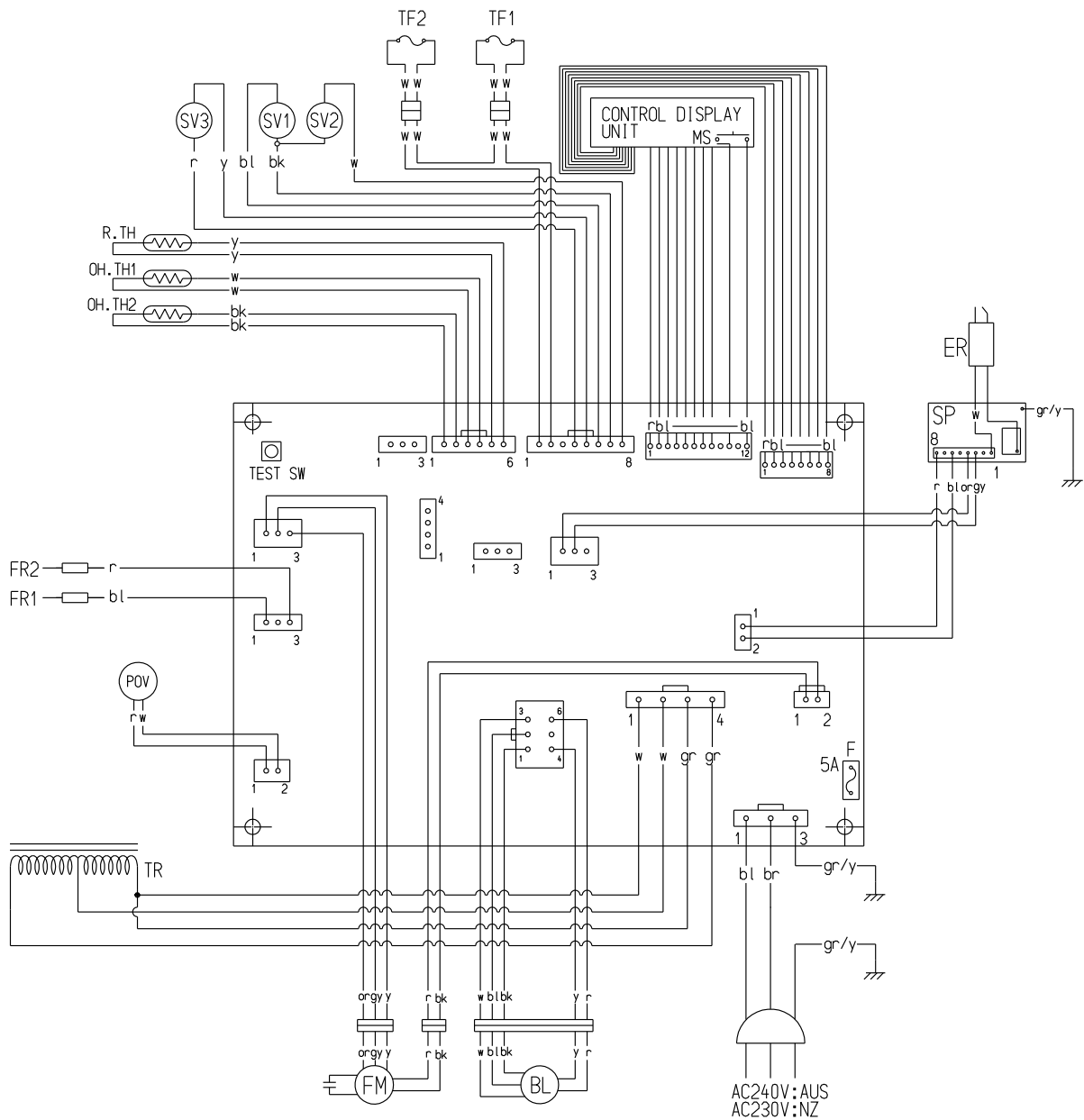

CODE	COLOR	CODE	COLOR
bk	black	w	white
bl	blue	y	yellow
gr/y	green/yellow	gy	gray
r	red	or	orange
gr	green	br	brown

MARK	PARTS NAME
MS	MAIN SWITCH
R.TH	THERMISTOR
TF1,2	THERMAL FUSE 1,2
F	FUSE
ER	ELECTRODE
POV	MODULATING SOLENOID VALVE
TR	TRANSFORMER
OH.TH1,2	OVER HEAT THERMISTOR 1,2
FM	CONVECTION FAN MOTOR
SP	SPARKER
SV1,2	MAIN SOLENOID VALVE 1,2
SV3	SOLENOID VALVE 3
BL	COMBUSTION FAN MOTOR
FR1,2	FLAME ROD 1,2

Limited Warranty

Rinnai brings you peace of mind with a:

2 Year minimum warranty

Terms and conditions

1. During the 24 month period from date of purchase and subject to clauses 2 and 3 below, Rinnai New Zealand Limited ("Rinnai") will, at its own discretion, either replace or repair any defective product at no charge to the customer.
2. This warranty covers manufacturing defects only. This warranty will not apply if (for example) the product has been improperly installed or is otherwise installed contrary to manufacturer's recommendations, has been damaged during or after installation, has not been operated

in accordance with operating instructions, or has been subjected to damage or abuse beyond that expected from conditions of normal use.

3. Warranty claims may be invalid if not accompanied by details of the installing or supervising gas fitter's registration number and the gas fitting certification number.
4. This warranty commences from the date of purchase. Proof of purchase is required at the time of any warranty claim.

5. Servicing of the product is to be carried out by a Rinnai authorised service centre.

All Rinnai appliances meet or exceed the safety standards required by New Zealand gas and electrical regulations. The company is constantly improving its products and as such specifications are subject to change or variation without notice.

RECORD YOUR DETAILS
OF PURCHASE BELOW:

Retailer:

Retailer address:

Date of purchase:

Product details:

ATTACH YOUR PROOF
OF PURCHASE HERE:



Please keep these details in a safe place for future reference.

Rinnai.co.nz

Tel: 0800 746 624
<http://www.youtube.com/rinnainz>
<http://facebook.com.rinnainz>



103112

RHF559-1153X07(00)

