

Model: RHPN361S



# HydraHeat Split Hot Water Heat Pump

## Installation guide

**Rinnai**

---

# Important

---

This hot water system shall be installed in accordance with:

- Manufacturer's installation instructions

Current:

- AS/NZS 3000 Electrical Standards
- AS/NZS 3500 Plumbing and Drainage Standards
- AS/NZS 5149 Refrigerating Systems Operation
- New Zealand Building Code Clause G12 Water Supplies

Appliance must be installed, commissioned, serviced, and removed only by licensed tradespeople.

Not suitable as a spa or swimming pool heater.

Not suitable for hydronic systems or for in-series installation in ring main systems.

## **Warning**

Improper installation, adjustment, alteration, service, maintenance, and removal can cause property damage, personal injury or loss of life.

This system is not to be used by persons (including children) with reduced physical, sensory or mental capabilities, or lack of experience and knowledge, unless they have been given supervision or instruction.

For more information about buying, using, and servicing of Rinnai appliances call: 0800 RINNAI (0800 746 624).

Rinnai New Zealand Limited  
105 Pavilion Drive, Mangere, Auckland  
PO Box 53177, Auckland Airport, Auckland 2150

Phone: (09) 257 3800  
Email: [info@rinnai.co.nz](mailto:info@rinnai.co.nz)  
Web: [rinnai.co.nz](http://rinnai.co.nz)  
[youtube.com/rinnainz](https://www.youtube.com/rinnainz)  
[facebook.com/rinnainz](https://www.facebook.com/rinnainz)

---

# Contents

---

|   |    |
|---|----|
| Important information.....                      | 4  |
| Before you start .....                          | 5  |
| Specification .....                             | 6  |
| Dimensions (mm) .....                           | 7  |
| Cylinder criteria.....                          | 7  |
| Clearances .....                                | 8  |
| Data label .....                                | 8  |
| Schematic.....                                  | 9  |
| Location.....                                   | 10 |
| Connections and plumbing arrangement .....      | 12 |
| Connecting the heat pump and cylinder .....     | 14 |
| Cylinder connections .....                      | 15 |
| Electrical supply and connections .....         | 16 |
| Connecting the cylinder temperature sensor..... | 18 |
| Plumbing schematic - side port connection ..... | 20 |
| Plumbing schematic - top port connection.....   | 20 |
| Wiring diagram heat pump unit.....              | 21 |
| Wiring diagram: New installation .....          | 22 |
| Wiring diagram: Retrofit.....                   | 23 |
| Commissioning .....                             | 24 |
| Error / warning codes .....                     | 26 |
| Storage and delivery temperatures .....         | 28 |
| Water quality.....                              | 29 |
| Controller interface .....                      | 30 |
| Appendix: Commercial concept sketches .....     | 32 |

# Important information

## WARNING

Installation and service to be carried out by a licensed tradesperson.

**DO NOT** operate this system before reading the operation and installation information.

**DO NOT** place articles on or against this appliance.

**DO NOT** store chemicals or flammable materials near this appliance.

**DO NOT** operate with panels or covers removed from this appliance.

**DO NOT** supply heat to any fittings when making connections. Ensure all pipes are clean and free from any foreign matter before making connections. Check water leaks at all joints. Damage caused by leaking joints is not covered by warranty.

**DO NOT** build this appliance in such a way that it cannot be easily serviced or replaced. Additional cost incurred by such installations is not covered by warranty.

For safe operation the cylinder must be fitted with:

- A combination Temperature & Pressure Relief (TPR) Valve.
- One thermostat and one over-temperature control for the heating element.

Operation of the over-temperature cut-out indicates a possibly dangerous situation. It must only be reset by an authorised person after the appliance has been inspected and serviced.

**DO NOT** tamper or remove any of the safety devices noted above.

**DO NOT** operate this water heater unless all these devices are fitted and in working order.

## WARNING

The valve and drain pipe of the system must never be sealed or blocked.

**MAKE SURE** the entire system including the cylinder is full of water before energising the system. Failing to do so can cause irreparable damage to the heat pump unit.

## Heat pump handling

The heat pump must only be handled / lifted using the hand holds provided.

These exist either side of the unit. **NEVER** place the unit on its side.

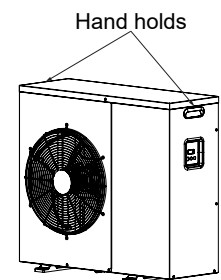

AS/NZS 60335.2.40

## WARNING

Do not use means to accelerate the defrosting process or to clean, other than those recommended by the manufacturer.

The appliance must be installed as specified in this installation guide, without continuously operating ignition sources in the vicinity.

Do not pierce or burn.

Be aware that refrigerants may not contain an odour.

## Electrical supply

Rinnai does not endorse the use of power supplies that supply clipped waveform AC power to the appliance and will not warrant any product connected to such a supply. Similarly if an appliance is supplied with an over-voltage / overcurrent supply, this is also not warrantable.

Voltage and frequency that matches the NZ legislative requirement for 230 V AC mains supply:

- Must be a standard 230 V nominal voltage
- Must be kept within 6% of that voltage, except for momentary fluctuations
- Must conform to a full sinusoidal AC waveform
- The frequency of electricity supplied must be maintained within 1.5% of 50 Hz, except for momentary fluctuations

Regardless of the means of that power generation, normal warranty provisions will apply. This means if your generator or inverter is able to provide power to the HydraHeat within the specification above, then the appliance will function correctly with a low chance of power supply related issues.

## Before you start

Unpack the appliance and components, and remove all transit packaging. Check for damage. DO NOT install any damaged items. Check all components have been supplied, refer below.

Read these instructions to get an overview of the steps required before starting the installation. Failure to follow these instructions could cause a malfunction of the appliance. This could result in serious injury and/or property damage.

### Heat pump unit

Ensure the heat pump is delivered the right way up as indicated on the carton. If the unit arrives inverted immediately place the right way up and allow one hour for rebalancing of the oil in the system. If, on inspection, oil has pooled out of the pipes DO NOT install.

### Cylinder connections

These MUST BE used. The connection used will be dependent on the installation and if the hot water outlet is to the side or at the top of the cylinder. Ensure the correct one is used, they are clearly labeled in the accessory pack.

### HydraHeat Split components

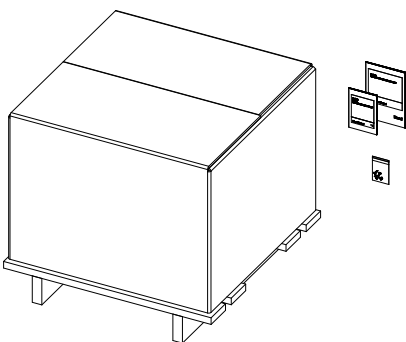

- Heat pump
- Operation, and installation guides
- Screw pack
- Quick start guide—A4 page taped to heat pump (a summary of the critical installation steps)
- Accessory pack
  - Cylinder connection top - top port adapter
  - Cylinder connection side - 15 mm nipple and tee
  - 15 m controller cable for cylinder thermistor<sup>1</sup>
  - Cylinder temperature thermistor
  - DN15 strainer
  - Drain valve

### Accessory pack



<sup>1</sup> Can go up to 20 m with the addition of the 5 m extension cable kit (R1012)

# Specification

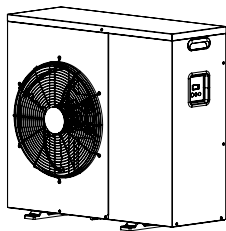

## Product description

Designed and assembled in New Zealand, the Rinnai HydraHeat Split is designed primarily for outdoor installations. It may be possible to install the HydraHeat internally if the proposed location is not an occupied space as defined by AS/NZS 5149, refer p.10 for more information.

The Rinnai HydraHeat is preset to 'Standard' mode—continually heating water to 60°C.

## Scope of use

- Retrofit or new build residential applications
- Connection to a compatible indoor or outdoor cylinder, refer cylinder criteria on next page

Must be installed in a location complying with clearances stated on p.12. The installation should be as close as possible to the cylinder.

Not suitable for spa or swimming pool heating, hydronic systems, or for in-series installation in ring main<sup>1</sup> systems. Hard or acidic water will need to be treated to use this product, refer water quality p.29.

**System MUST BE sized correctly:** As the heat pump operates at slightly lower temperatures than a traditional cylinder it may result in a reduced amount of available hot water. This needs to be factored when evaluating / sizing the hot water system.

<sup>1</sup> If using a ring main with any Rinnai heat pump, use a separate Rinnai electric ring main re-heating cylinder. Refer page 32 for more information.

|  |  |
|--|--|
| Construction and colour  | Galvanised steel powder coated Cod Grey (Dulux 9157924M)   |
| Operating temperatures   | -10 °C to +42 °C   |
| Outlet water temperature   | Standard: 60 °C, Eco 55 °C   |
| Storage capacity   | Will be based on the cylinder it is connected to   |
| Maximum valve pressure settings: <ul style="list-style-type: none"> <li>• TPR (required)</li> <li>• Cold water expansion valve</li> <li>• Pressure limiting valve</li> </ul> | <ul style="list-style-type: none"> <li>• Suitable TPR (rated 10 kW or more)</li> <li>• 700 kPa (must be installed)</li> <li>• 500 kPa</li> </ul> |
| Coefficient of performance (COP)   | 4.6 (Operating conditions 19 °C ambient, 19 °C water, eco mode 55)   |
| Rated heat pump input/output <sup>1</sup>  | 765 W / 3600 W   |
| Max. current (heat pump standard mode)   | 4.6 A  |
| Max. current heat pump (element only)  | 14.5 A   |
| Backup resistance element rating capacity  | 3000 W   |
| Min. inlet water pressure  | 100 kPa  |
| IP rating  | IP24<br>(protects from splashing water, no matter the direction)   |
| Water port connections   | G½ " (15 mm x 2)   |
| Sound pressure level at 1 m  | 48 dB(A) <sup>2</sup>  |
| Power supply   | 230-240 V 50 Hz  |
| Weights  | Net: 42.5 kg Gross: 50 kg  |
| Heat pump unit data label position   | Behind front cover, positioned on panel between compressor and fan   |
| Refrigeration type / mass (kg)   | R-290 / 150 g  |
| Refrigeration classification   | A3 flammable   |

<sup>1</sup> In standard and Eco 55 modes, the heat pump provides 100% of the heating within the operating temperature range (excluding the weekly Legionella cycle). Outside these limits the electric element will operate.

<sup>2</sup> Sound pressure level measured at 1 m distance from the water heater in a free field. Appliance operated in standard mode (60 °C) at an ambient temperature of 19 °C.

# Dimensions (mm)

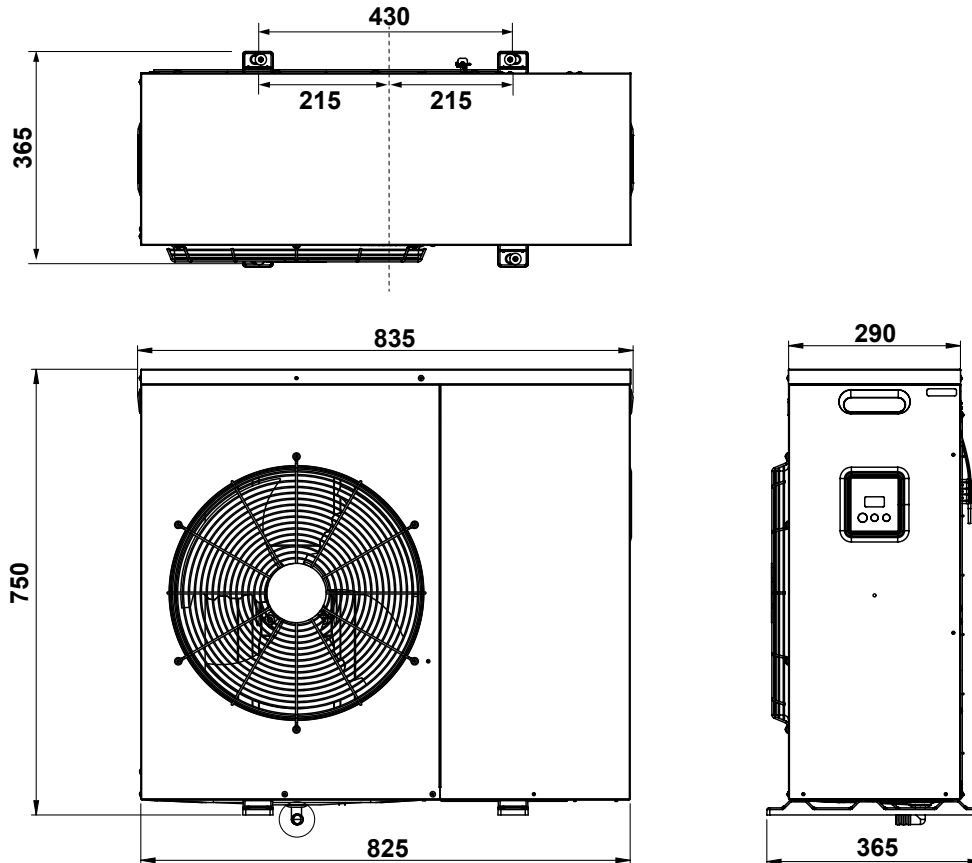

Drainage elbow circled above requires 50 mm min. below metal feet of heat pump

## Cylinder criteria

The cylinder to which the HydraHeat Split is connected must meet all of the following criteria. If you are unsure, an onsite inspection is recommended. Warranty does not cover connections to incompatible cylinders.

- Single element<sup>1</sup> mains pressure cylinder—eight years old or less, 180-340 L, element size 3 kW or less
- Cylinder not connected to supplementary heating (e.g. wetback, solar thermal etc)
- Suitable TPR (rated 10 kW or less)
- Pipe run length is less than 20 m (supplied cable is 15 m, extension cable is 5 m)
- Difference in height between base of cylinder and base of heat pump no more than 5 m
- If an indoor cylinder, an additional 100 mm in height for top port connections, or and additional 100 mm in width for side port connections.
- Cylinder thermostat set at 70 °C, this temperature is required to ensure 'Element only' mode and Legionella disinfection cycles function correctly



<sup>1</sup> The cylinder element must be operational and properly connected, as it is essential for both the operation and compliance of Legionella disinfection. The 70 °C MUST NOT be adjusted—any changes will void the warranty.

# Clearances (mm)

Correct location is essential for optimum performance. Many problems with poorly performing heat pumps are due to poor location of units.

Locate outdoor units:

- to allow unimpeded air flow around the unit (to avoid the creation of a microclimate that reduces heat pump performance and efficiency)

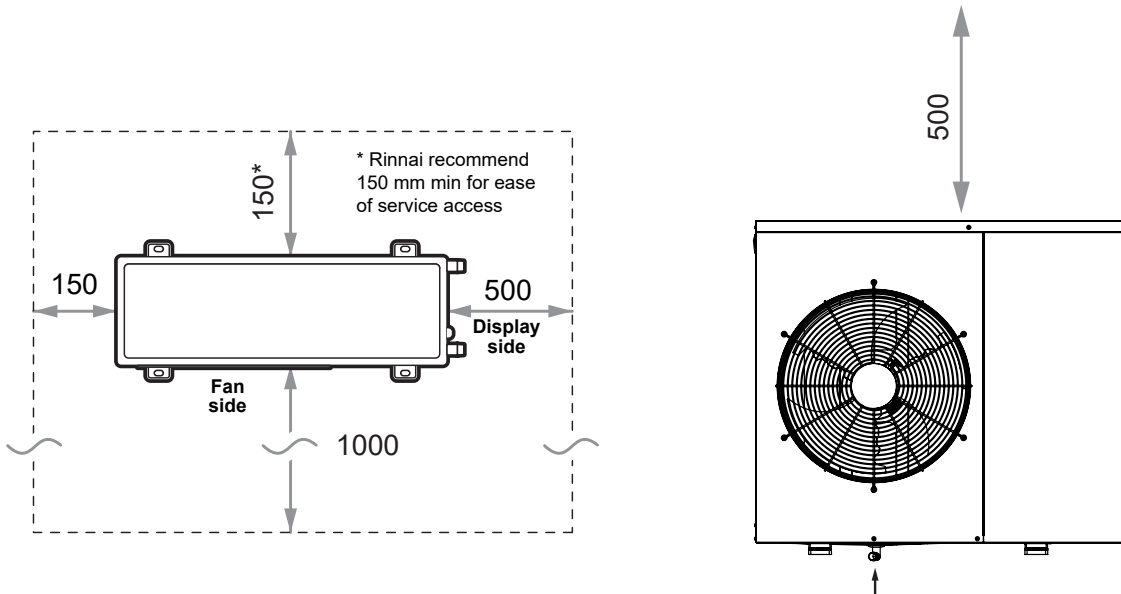

Drainage elbow requires 50 mm min. below feet of heat pump

# Data label

Positioned behind the front cover and positioned on the panel between the compressor and fan, as shown below.

| <b>Rinnai Hot Water Heat Pump</b>          |                                    |
|--|------------------------------------|
| <b>Model</b>                               | RHPN361S                           |
| <b>Refrigerant</b>                         | R290                               |
| <b>Refrigerant operating pressure</b>      | 2.5 MPa maximum                    |
| <b>Water operating pressure</b>            | 100 kPa minimum<br>700 kPa maximum |
| <b>Water inlet temperature</b>             | 5 °C minimum<br>30 °C maximum      |
| <b>Water outlet temperature</b>            | 55 °C minimum<br>60 °C maximum     |
| <b>Power</b>                               | 230-240 VAC 50 Hz, 16 A            |
| <b>IP rating</b>                           | IPX4                               |
| <b>Manufactured date</b>                   | YY / MM                            |
| Manufactured by Rinnai NZ Ltd, Auckland NZ |                                    |



# Schematic

- All weather OLED (organic light emitting diode) display, capacitive (uses conductive touch of a human finger)

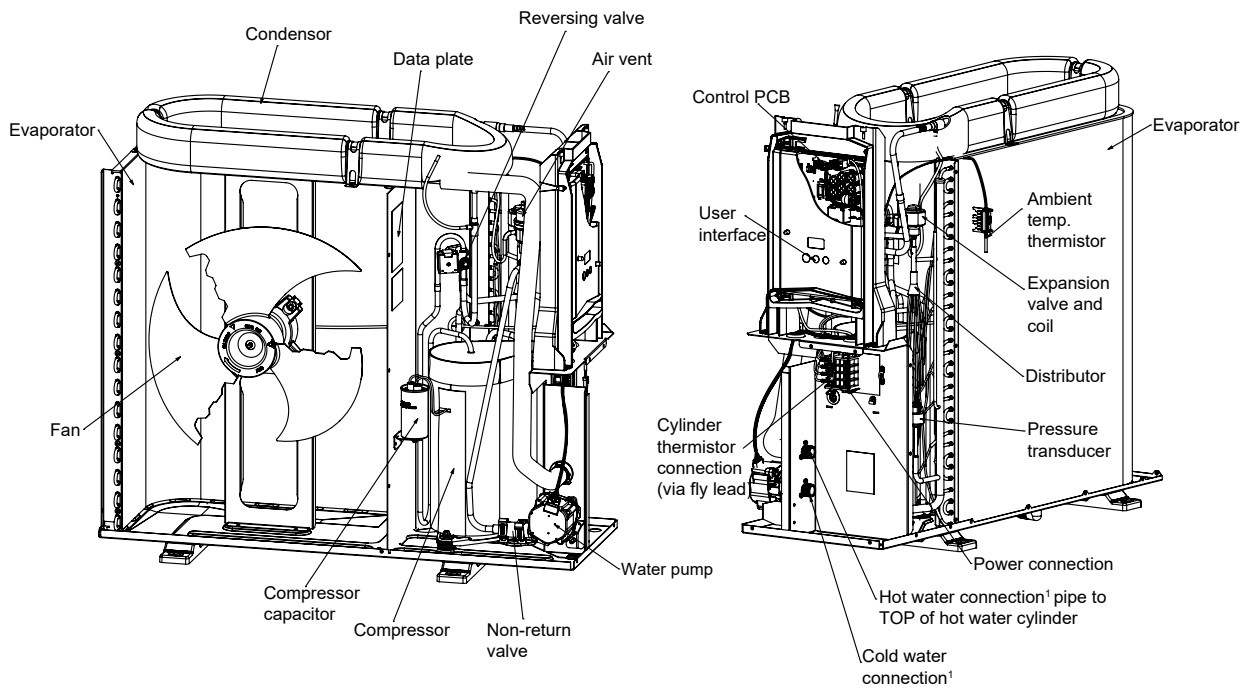

<sup>1</sup> Critical to pipe these correctly. To assist installation these connections are clearly labeled, refer image below.

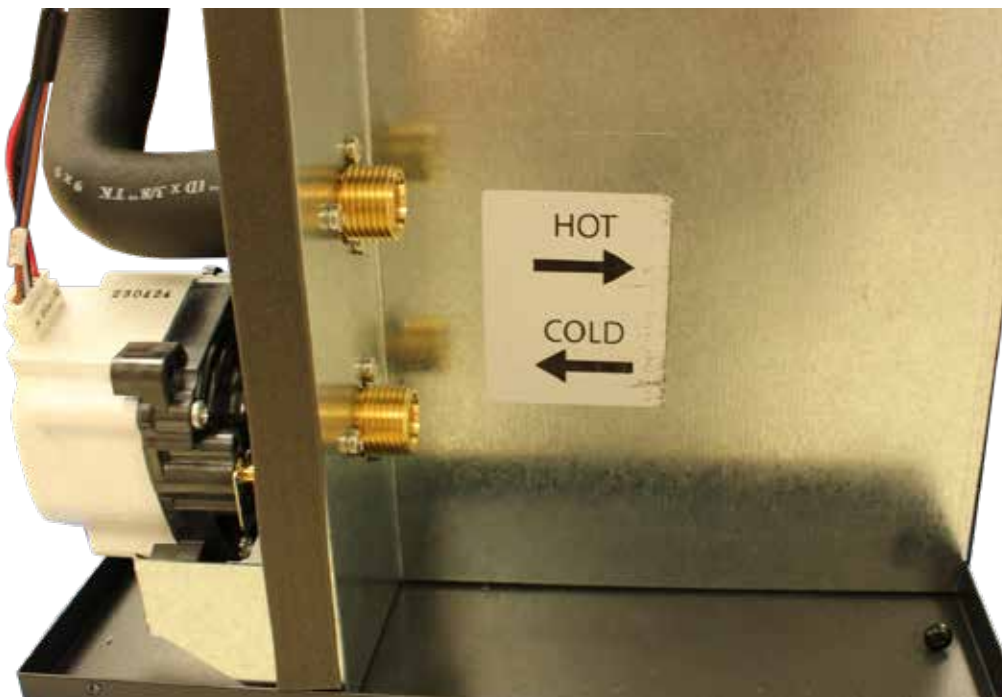

# Location



As the heat pump contains flammable refrigerant, ensure the installation location complies with the requirements of AS/NZS 5149. **DO NOT** install the unit in a location that may be exposed to combustible gas leaks. If combustible gas accumulates around the unit, it may cause a fire.

The HydraHeat is designed primarily for outdoor installation. It may be possible to install the HydraHeat Split internally if the proposed location is **not an occupied space** as defined by AS/NZS 5149.1 3.2.6. An extract has been provided below for those that do not have access to this standard.

## 3.2.6

### occupied space

space in a building bounded by walls, floors, and ceilings and which is occupied for a significant period by persons.

Note 1 to entry: Where the spaces around the apparent occupied space are, by construction or design, not airtight with respect to the occupied space, these can be considered as part of the occupied space, e.g. false ceiling voids, crawl ways, ducts, movable partitions, and doors with transfer grilles.

The HydraHeat, by the above definition, would **not be** suitable for installation into an attached garage.

Examples of an unoccupied space:

- Adequately ventilated plant room
- Adequately ventilated shed



Internally installed units will need adequate ventilation as the appliance has a cooling effect on the installed space, operating noise should also be considered.

### Avoid installing:

- Directly below an opening window, the system discharges a large volume of cold air.
- In areas where the air inlet and outlets could get blocked / clogged.
- In highly planted areas where falling leaves and other debris could block the air vents or potentially damage the unit.
- In areas with multiple structures, for example fences, concrete walls, retaining walls, screens etc unless these are well ventilated to let the cold air escape.



The HydraHeat can be installed in coastal locations, but not immediately facing salt spray or prevailing winds. It needs some form of shelter otherwise salt will quickly clog the evaporator.

## Noise



Ensure that the installation location complies with local noise regulations regarding neighbouring properties. The location must consider noise impact on living areas. Avoid positioning near bedrooms or neighbours bedrooms. Although the running noise level is low it can be expected that the heat pump will run during the night. The timer function can be used to limit operating hours if noise is a concern.

- Avoid placing the unit less than 3 m from a neighbour's window (windows are less soundproof than walls, and they can be opened), or door other than a garage door or shed.
- Avoid placing the unit near boundary lines.



- DO NOT place any objects on top of the unit, this could cause excessive vibration and increase noise levels.

## Orientation



The heat pump is designed for open air operation, requiring sufficient air supply to maintain operating efficiency.

The air inlet and outlet of the heat pump must be positioned away from prevailing winds and must be provided with sufficient clearances as shown p.8.

Consideration to the orientation of the control interface is important as the homeowner / end user will need adequate room to view and interface with the control pad.

## Accessibility



The heat pump MUST be installed in a vertically upright position. All components must be accessible without the use of a ladder or scaffold.

Ensure the pressure and TPR valve (of the cylinder), and any access covers have sufficient clearances and are accessible for service and removal. The information on the rating plates MUST also be readable.

## Base requirements



The heat pump must be installed in an upright position on a level, stable and water impervious base. The base must be capable of withstanding the weight of a full system.

Consideration should be given to the base to prevent water ponding, and installations should allow water to drain and dry. Ensure the HydraHeat does not stand on permanently wet surfaces,

It's best to install the unit on the ground for easy access, servicing, troubleshooting, and user interaction with the display. However, it can also be wall-mounted on solid surfaces like concrete. Avoid mounting it on timber walls, as vibrational noise can be problematic.

## Snow zone locations



In areas where heavy snowfalls are expected, ensure the unit has snowfall protection over the unit. It may need to be mounted higher off the ground to avoid blockage. Ensure that the minimum clearances are adhered to.

# Connections and plumbing arrangement

The cylinder component of the system must be installed in accordance with G12/AS1, and AS/NZS 3500.4. For service and maintenance, please allow sufficient room for access to covers and valves. All pipe work should be insulated with polythene foam or equivalent insulation to optimise performance and energy efficiency. This includes all water fittings.

All hot water supply parts must comply with AS/NZS 3500.4 and G12/AS1.

For an appliance intended to be permanently connected to the water mains and not connected by a hose set.



- The valve or drain valve outlet pipe must not be sealed or blocked.
- Valves with pressure ratings other than those listed in this manual must not be used.
- A discharge pipe connected to the pressure relief device is to be installed in a continually downwards direction and in a frost free environment.

## Pipe work (pipe connection DN15)

It is the installer's responsibility to adequately size the distribution pipe work in a property to ensure sufficient performance from all outlet fittings. Water pipe sizing should be performed in accordance with AS/NZS 3500.4 and/or G12/AS1. Pipe sizing and valve selection must be performed to allow for the water supply pressure. All pipework needs to be secured to stop water hammer.

DO NOT drill anything into the cylinder or heat pump, this could damage critical components and cause corrosion.

## Drain valves

In accordance with AS/NZS 3500.4 5.11.3, drain lines from temperature / pressure-relief valves, expansion control valves and tundishes shall be installed and located so as not to cause a nuisance, is readily discernible and incurs no risk or damage to the building (including slabs and footings) or injury to persons.

## Safe tray (indoor cylinder installations)

Where there is potential of damage occurring from a leaking system, a suitably drained safe tray is fitted as per AS/NZS 3500.4 5.4 and G12/AS1 6.11.3.

## TPR valve

Ensure that the installed TPR is rated at 10 kW or less, and that it is correctly fitted in conjunction with the appropriate connection fitting provided in the accessory pack.

A TPR valve is essential for the safe operation of the hot water system. Failure to install the appropriate TPR correctly can lead to potential injury and damage to the unit.

The TPR valve should be connected to a vertical discharge pipe that enables water to flow downwards at all times. The TPR discharge pipe outlet should be positioned such that the outlet hot water cannot cause injury to persons or damage to the building.

## Drain elbow and condensate

During normal operation, condensation occurs in the heat pump as air across the evaporator is cooled. In high humidity locations a large volume of condensate can be generated, this needs to be plumbed into a condensate drain and gully trap—19 mm tapered connection (clear flexible PVC drain hose).

A drain elbow is provided with the heat pump unit, which must be attached to a 19 mm condensate drain hose (not supplied). The elbow requires a minimum of 50 mm below the feet of the heat pump.

## High level overview of connections

For ease of reference not all plumbing and electrical parts are included in the below drawing, for example safe tray, drains, isolating valves, restraints etc.

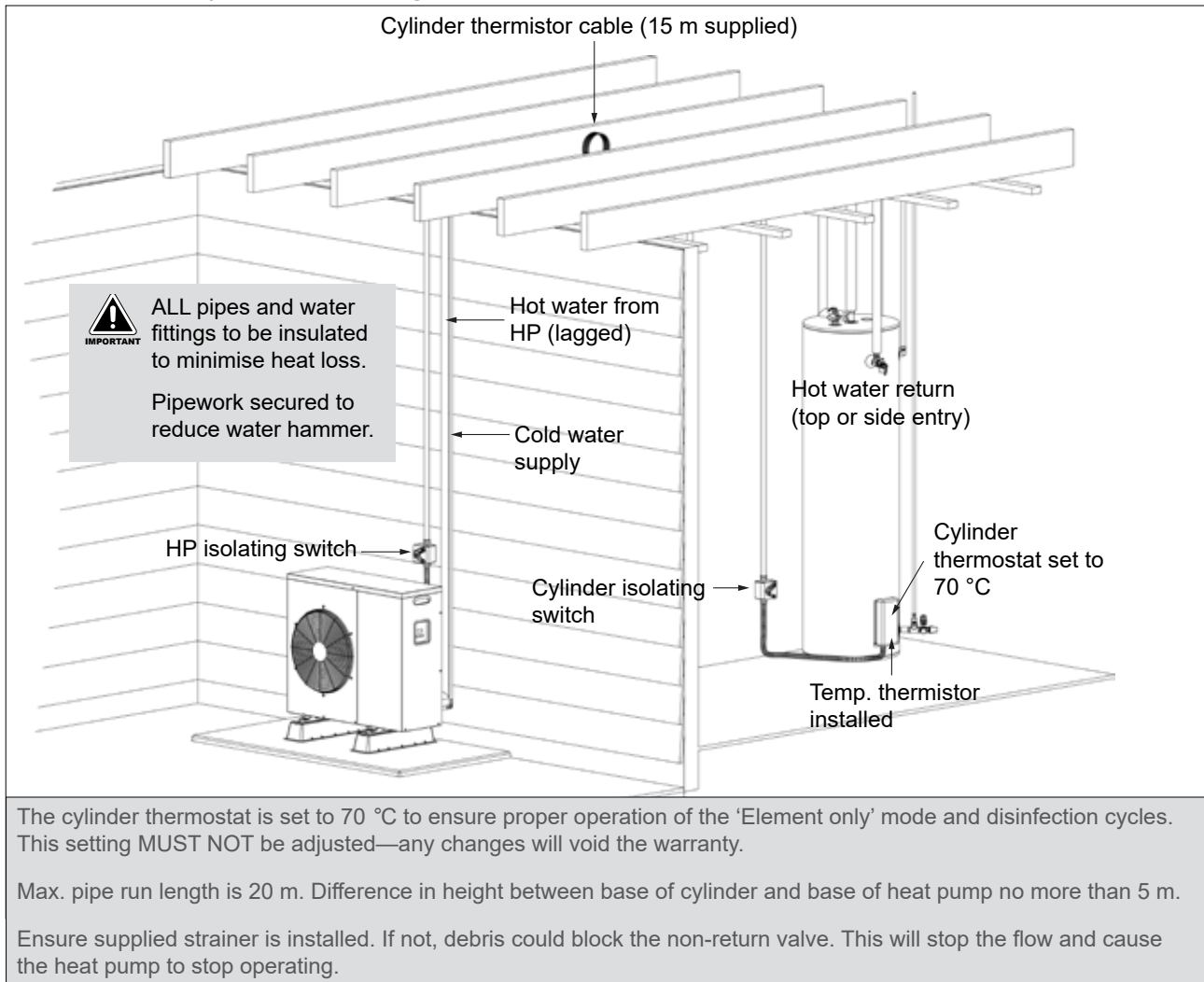

### 1. Heat pump isolating switch

When the heat pump is isolated the cylinder element will also be isolated.

### 2. Cylinder isolating switch

Enables power to the cylinder to be isolated if working on the thermostat or element. It does not isolate power to the heat pump.

### 3. Cold water supply

The cold water supply to the heat pump can be from a secondary inlet port or teed off from an existing inlet port. The tee (circled below) must be fitted as close to the cylinder as possible. The maximum water pressure for the heat pump is 700 kPa.

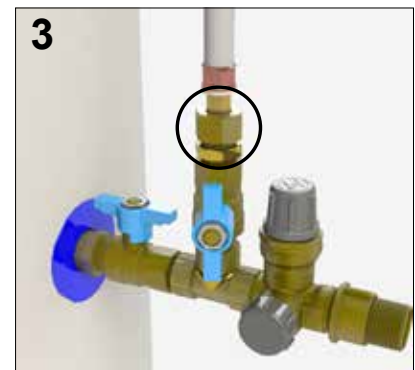
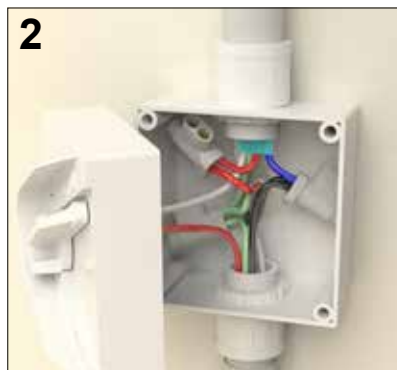
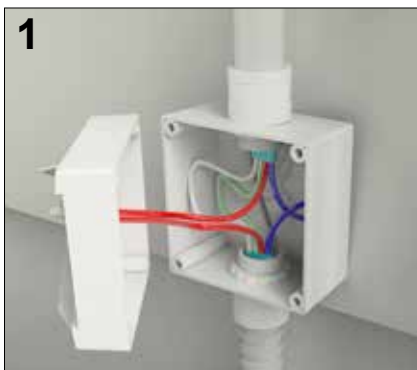

# Connecting the heat pump and cylinder

For the heat pump to cylinder connection the side cover panel needs to be removed. Undo the four screws and allow the cover panel to drop down to clear the top panel.

Before fitting the upper hot, and lower cold water connections, both pipes should be flushed with water to reduce the potential for an air lock within the system. There is an air vent within the heat pump, although it may not be sufficient to remove all of the air in the inlet line.

There is a non-return valve fitted next to the water pump that will only allow water to pass from the cold to the hot side of the system.

## Plumbing requirements

Supply and return lines shall be piped in fully insulated DN15 copper or plastic piping (other sizes not to be used). All piping and associated fittings shall be rated by the manufacturer for continuous operation at 65 °C and 700 kPa operating pressure for the lifespan of the appliance. Insulation shall be of a UV rated polyolefin or elastomeric nitrile type, a minimum thickness of 13 mm and must run the entire length of the pipe and cover all bends and fittings. Two isolating valves must be fitted between the supply and return lines and the hot water cylinder connections.

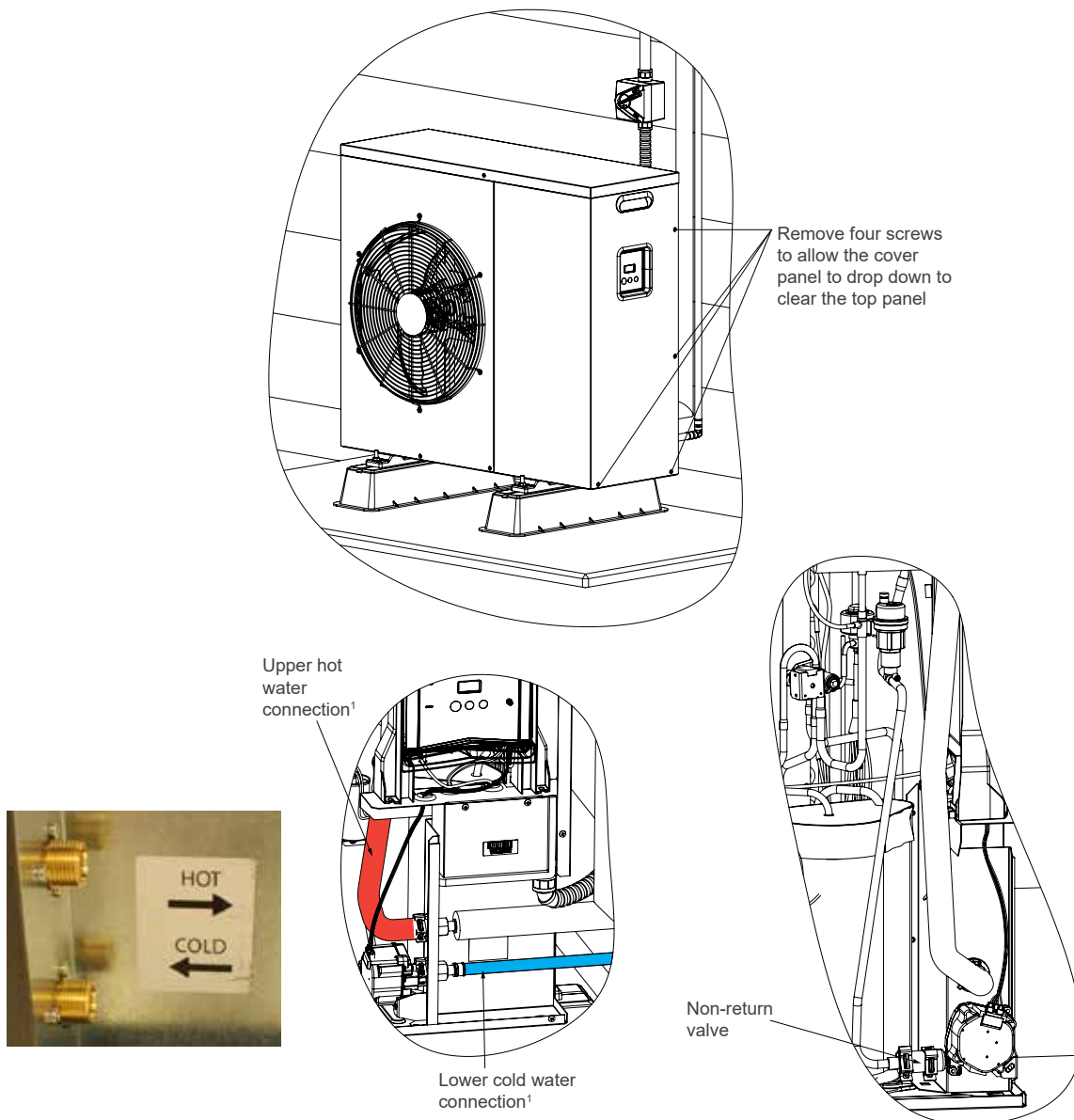

<sup>1</sup> Critical to pipe these correctly. To assist installation these connections are clearly labeled.

# Cylinder connections

## Top hot water outlet port connection

For cylinders with a top hot water port, remove the current outlet fittings and replace with the special tee adapter supplied with the heat pump. Make sure that the long injection tube is fitted to the tee. This ensures that the hot water is injected below the top of the cylinder. Failure to install this tee may result in temperature fluctuations and potentially damage the heat pump.

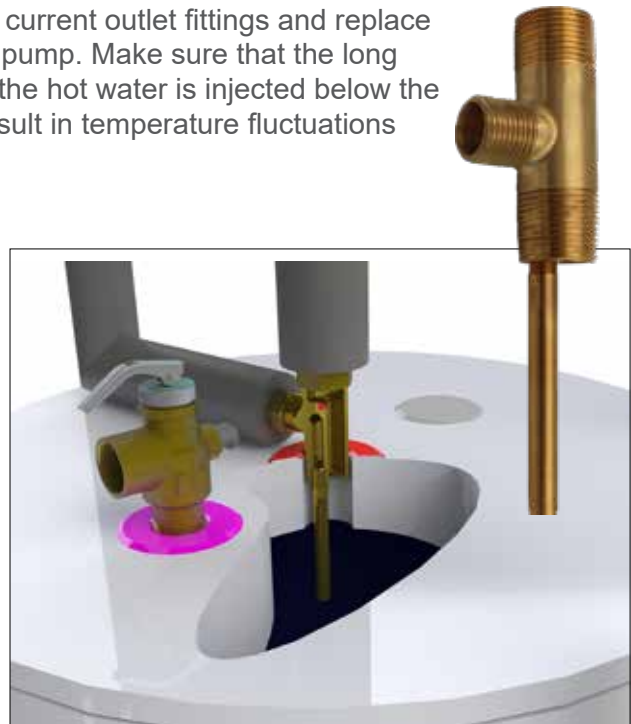
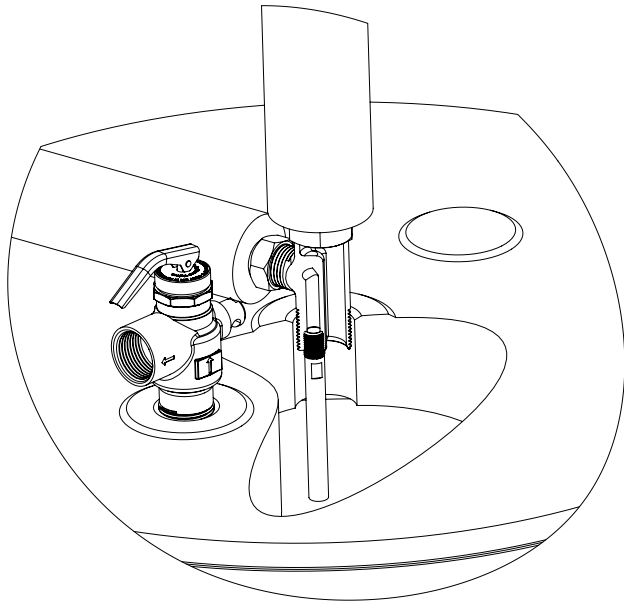

## Side hot water outlet port connections

For cylinders with side hot water port(s), use the supplied tee and nipple and connect the hot supply from the heat pump through the **TPR port**. **DO NOT** use the cylinder hot water port(s) to connect the heat pump hot supply pipe as this will lead to temperature fluctuations and potentially damage the heat pump.



1. Remove and inspect TPR.
2. Fit tee and nipple supplied with heat pump.
3. Refit TPR, replace if required.
4. Fit hot water return from heat pump to tee (first metre min. must be in copper)

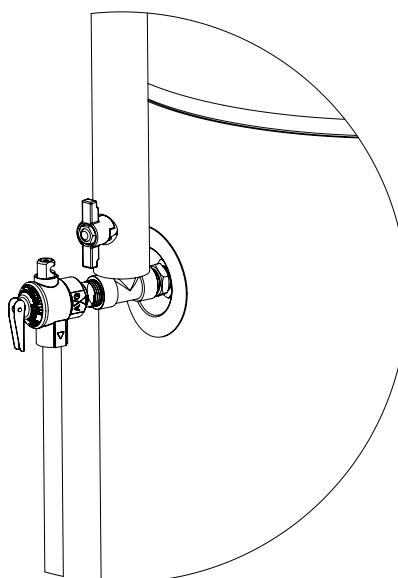
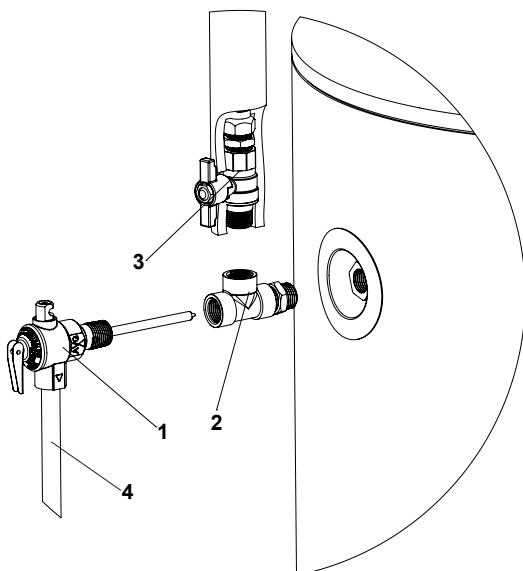

# Electrical supply and connections

The electrical connection must be carried out by a qualified person in accordance with the latest version of AS/NZS 3000 Wiring Rules.

The heat pump will directly control the element using the main PCB's primary relay. A qualified person will handle the electrical installation and termination of the heat pump to the hot water cylinder.

It **MUST** have the electric terminals connected to an independent, fused AC 230 V 50 Hz power supply. An isolating switch (lockable) must be installed in accordance with AS/NZS 3000 clause 4.19.

- The power supply to the heat pump unit **MUST NOT** be activated until the system is filled with water. Failure to follow this requirement may result in damage to the wiring in the element due to overheating.
- Household wiring to the system must be capable of withstanding the appliance load.
- Fixed wiring must be protected from contact with the internal surfaces of the system.

Connect all LIVE, NEUTRAL and EARTH wires in accordance with the wiring diagrams.

Inspect and ensure all wiring links are secure prior to fixing the access cover and turning the power on.

Once the cylinder is full of water perform an earth continuity test.

1. Remove the four screws from the heat pump side cover panel to drop down to clear the top panel.
2. Remove screws to uncover the electrical connection.

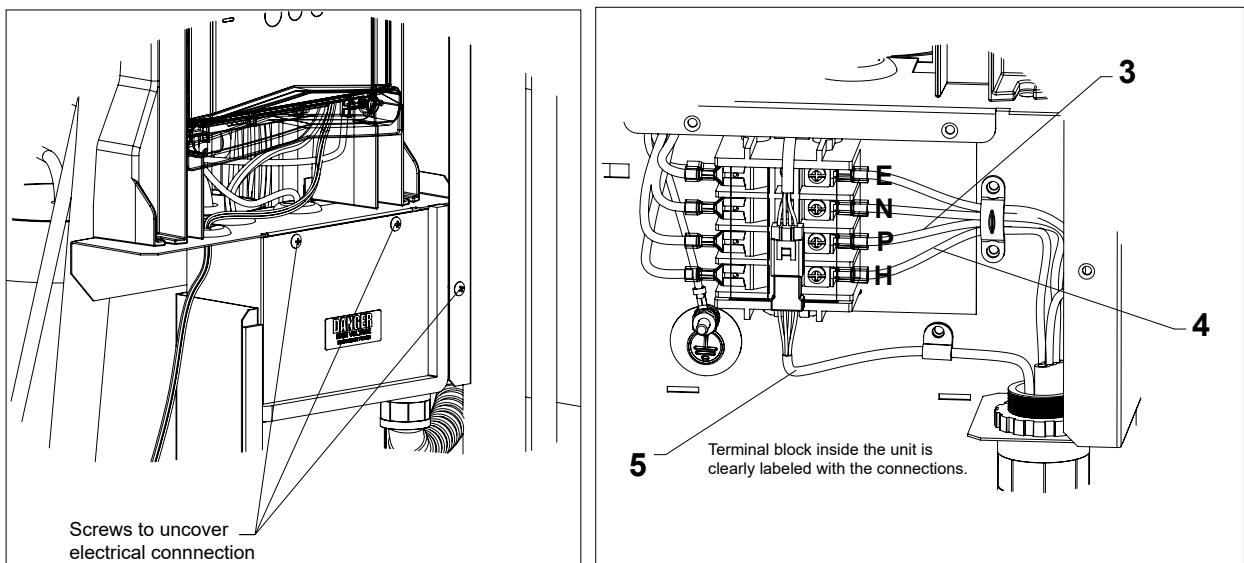

3. Connect power (switched power supply). Must be connected to a 15 A rated power supply.
4. Connect control wire for cylinder heating element (controlled by heat pump). Maximum element size is 3 kW. If the cylinder is fitted with a higher rated element, replace the element with one that is rated at 3 kW or less.

Note: The cylinder and heat pump share a common earth and neutral connection.

5. Connect the sensor cable from the heat pump to the cylinder element penetration (where the lower cylinder sensor is to be located).

## Isolating switches

Switching off power to isolate the heat pump will also cut off power to the cylinder's heating element. While the cylinder isolation switch can turn off the heating element, the heat pump will still remain powered.

Ensure that the power supply to the heat pump isolating switch is at least 15 A.

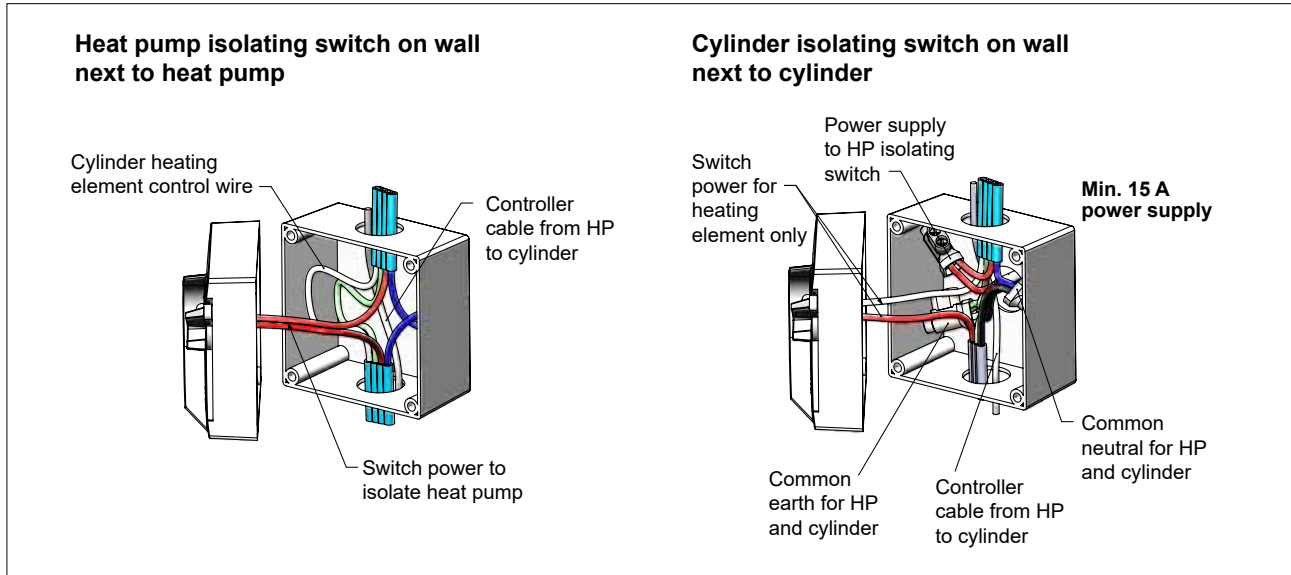

# Connecting the cylinder temperature sensor



This step is crucial for the heat pump's operation. Make sure the temperature sensor is installed as shown and secured to prevent it from falling out. It should be positioned at the top of the enclosure. If not installed correctly, it will result in a T1 fault due to the inability to accurately read the tank temperature, which could occur once the installer has left site.

1. Remove element cover.
2. Unclip and remove thermostat from bracket. Image shows a Rinnai cylinder.
3. Using sandpaper (or equivalent), remove the tank scale (common with enamel tanks). This ensures the thermostat has good surface contact.
4. Push thermistor flag up into the top right hand corner between the insulation and the cylinder. Ensure the flag does not buckle, it needs to lie flat against the cylinder as per the diagram on the next page. Use combination pliers if necessary.
5. Take supplied foam tape with self-adhesive backing and tape directly underneath the flag. This ensures it does not move and won't fallout.
6. Refit the thermostat and route the thermistor cable around the outside of the thermostat leads. Having the cable and leads touching could result in a short circuit.
7. Replace element cover.
8. Connect cylinder temperature sensor into the extension cable from the heat pump, and connect power to the cylinder.
9. Once installed run the thermistor cable in conduit, while it is double insulated it should not be exposed.

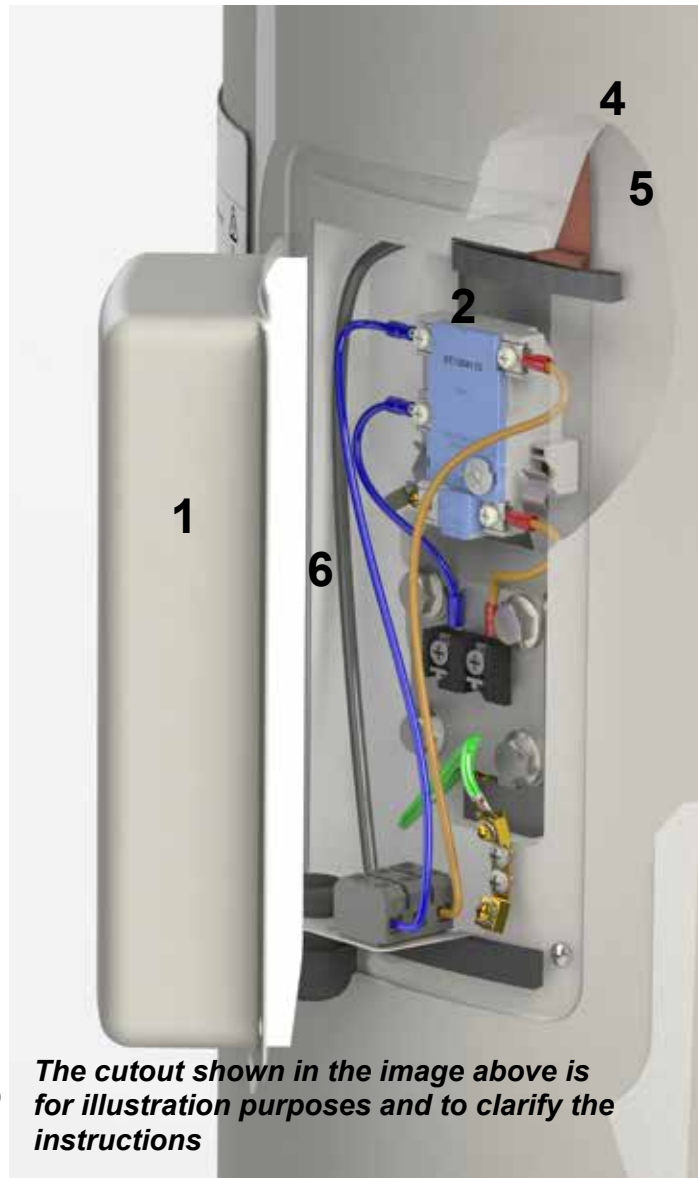

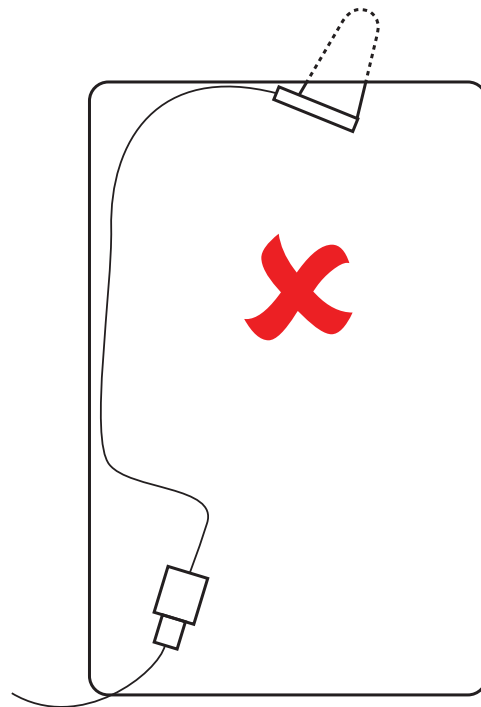
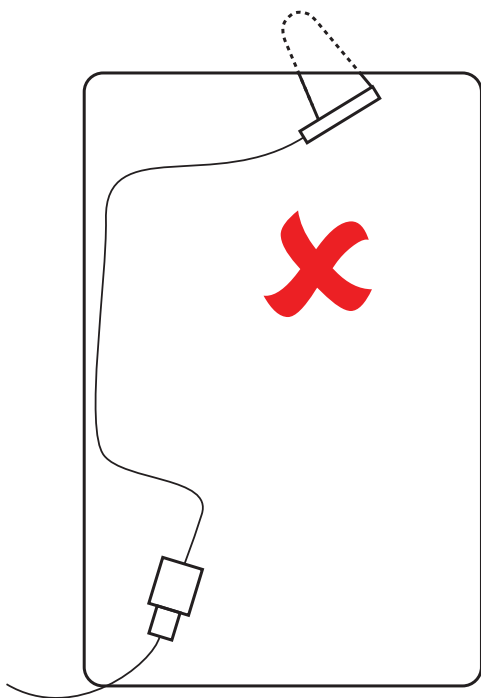
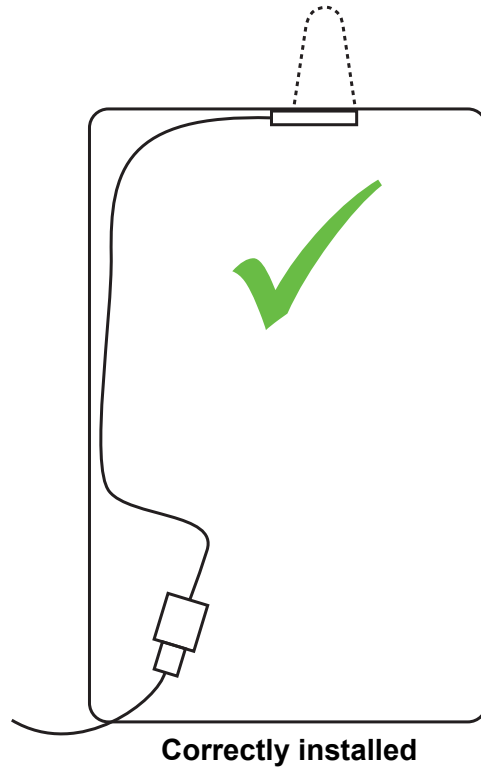
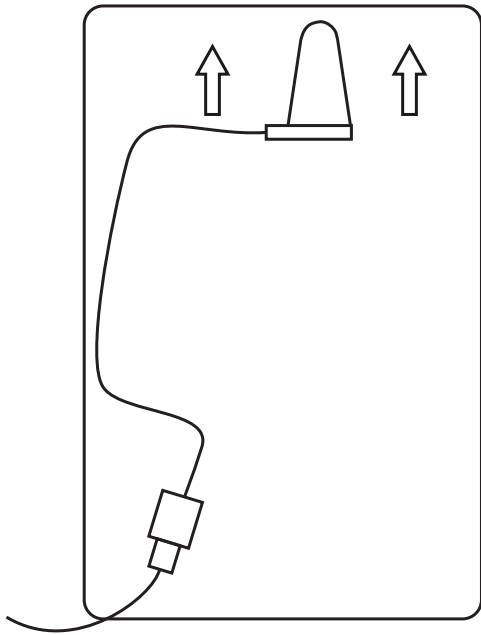

# Plumbing schematic - side port connection

For approved cylinders with side hot water ports—contact Rinnai to check.

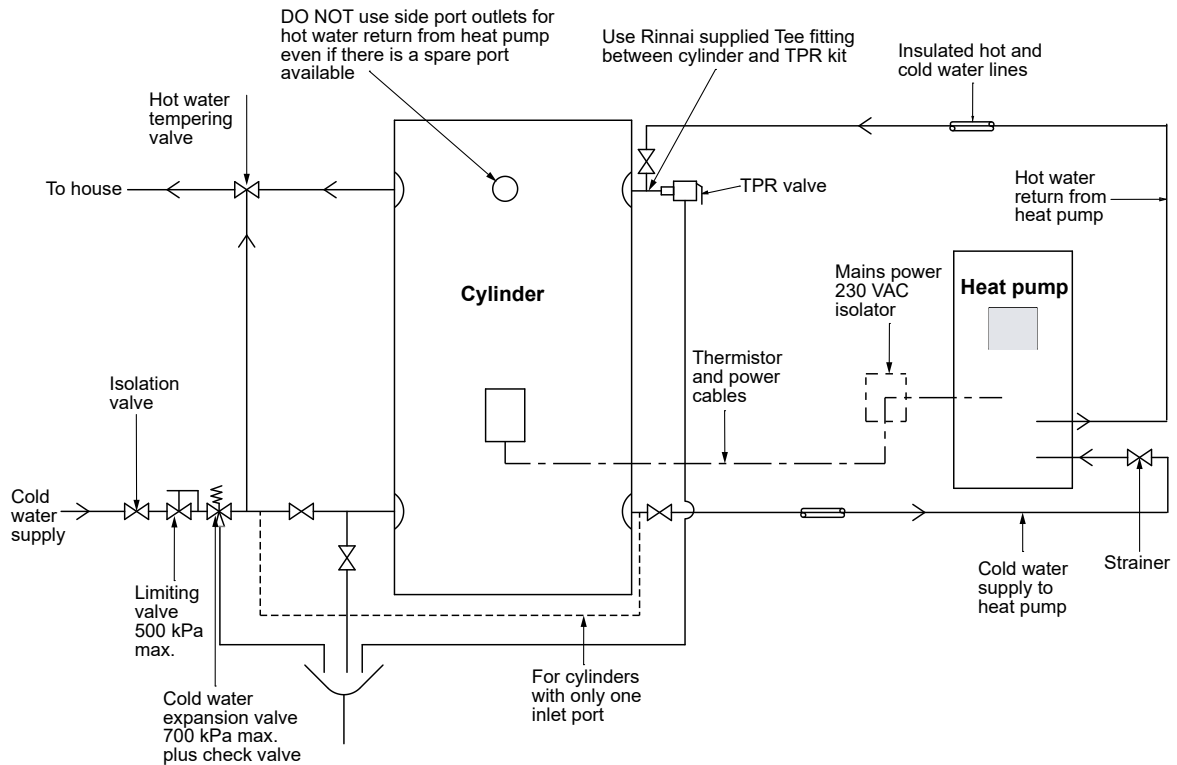

The supplied strainer must be installed in the inlet line to the heat pump as shown. If not, debris could block the non-return valve. This will stop the flow and cause the heat pump to stop operating.

# Plumbing schematic - top port connection

For approved cylinders with top hot water ports—contact Rinnai to check.

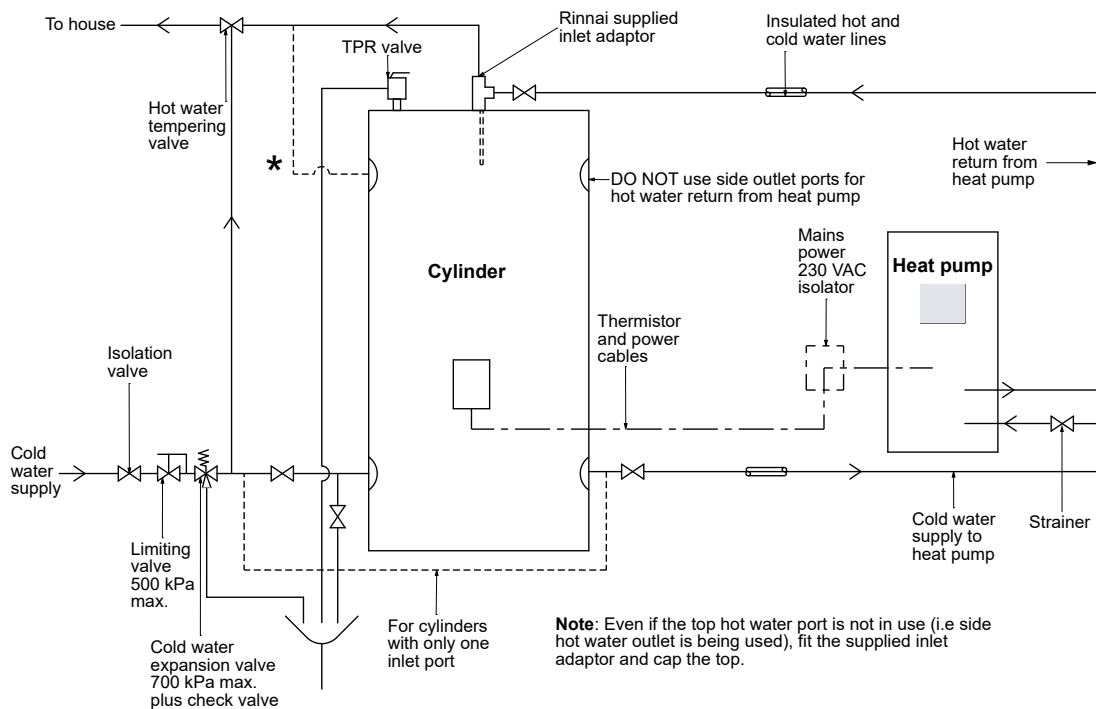

# Wiring diagram heat pump unit

The heat pump unit wiring diagram is on the back of the plastic user interface screen.

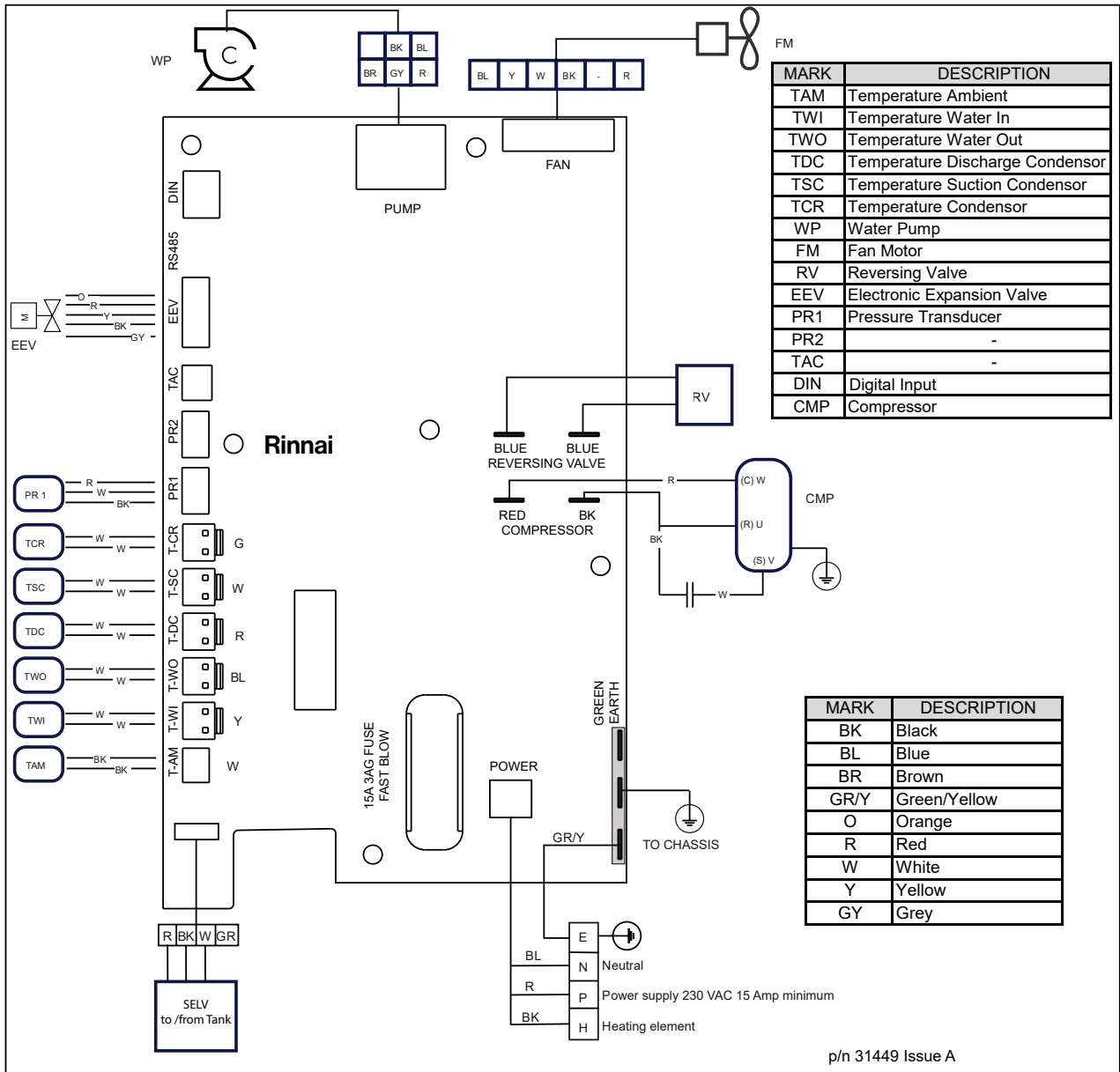

# Wiring diagram: New installation

Power supply at heat pump switch

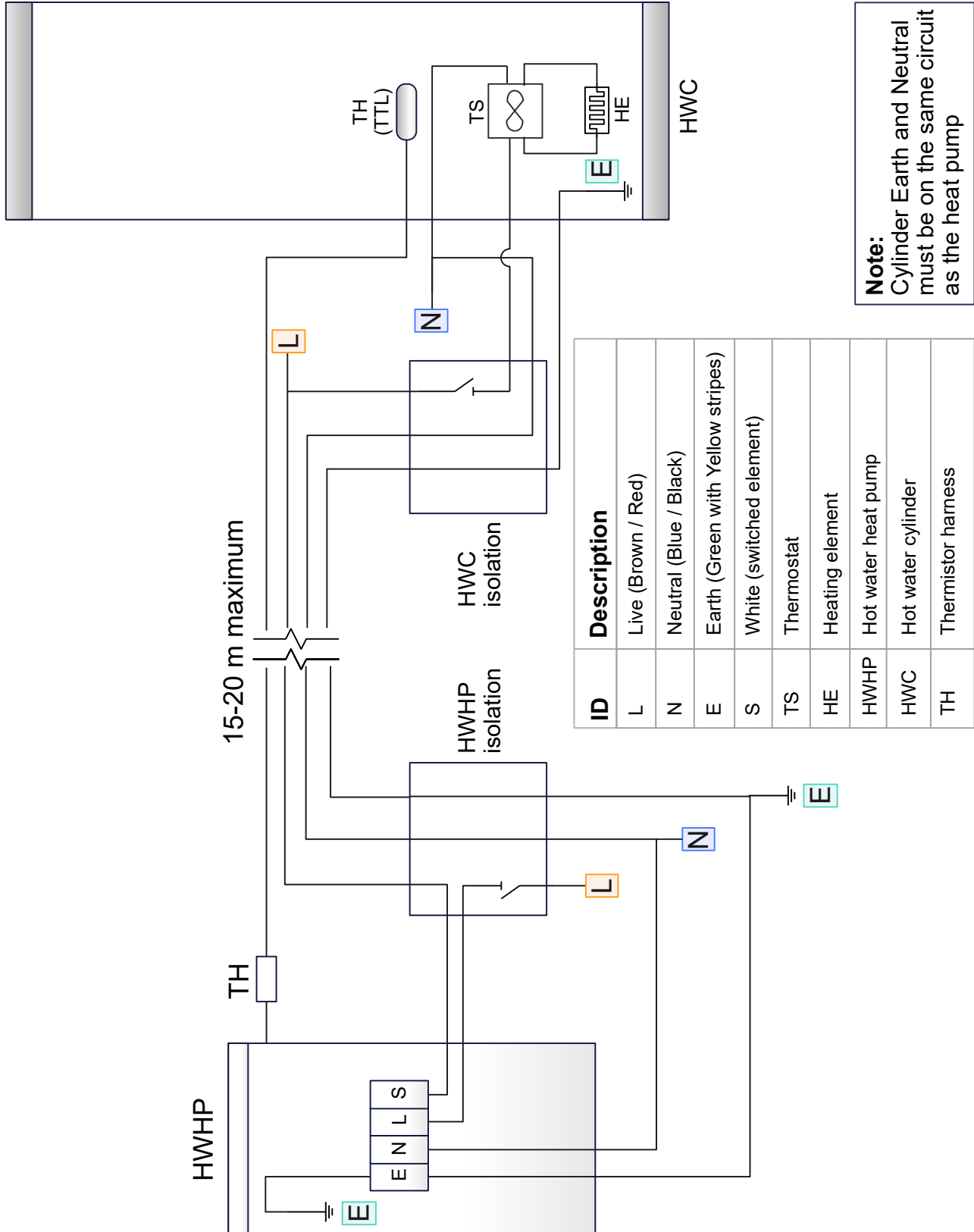

# Wiring diagram: Retrofit

## Power supply at water cylinder

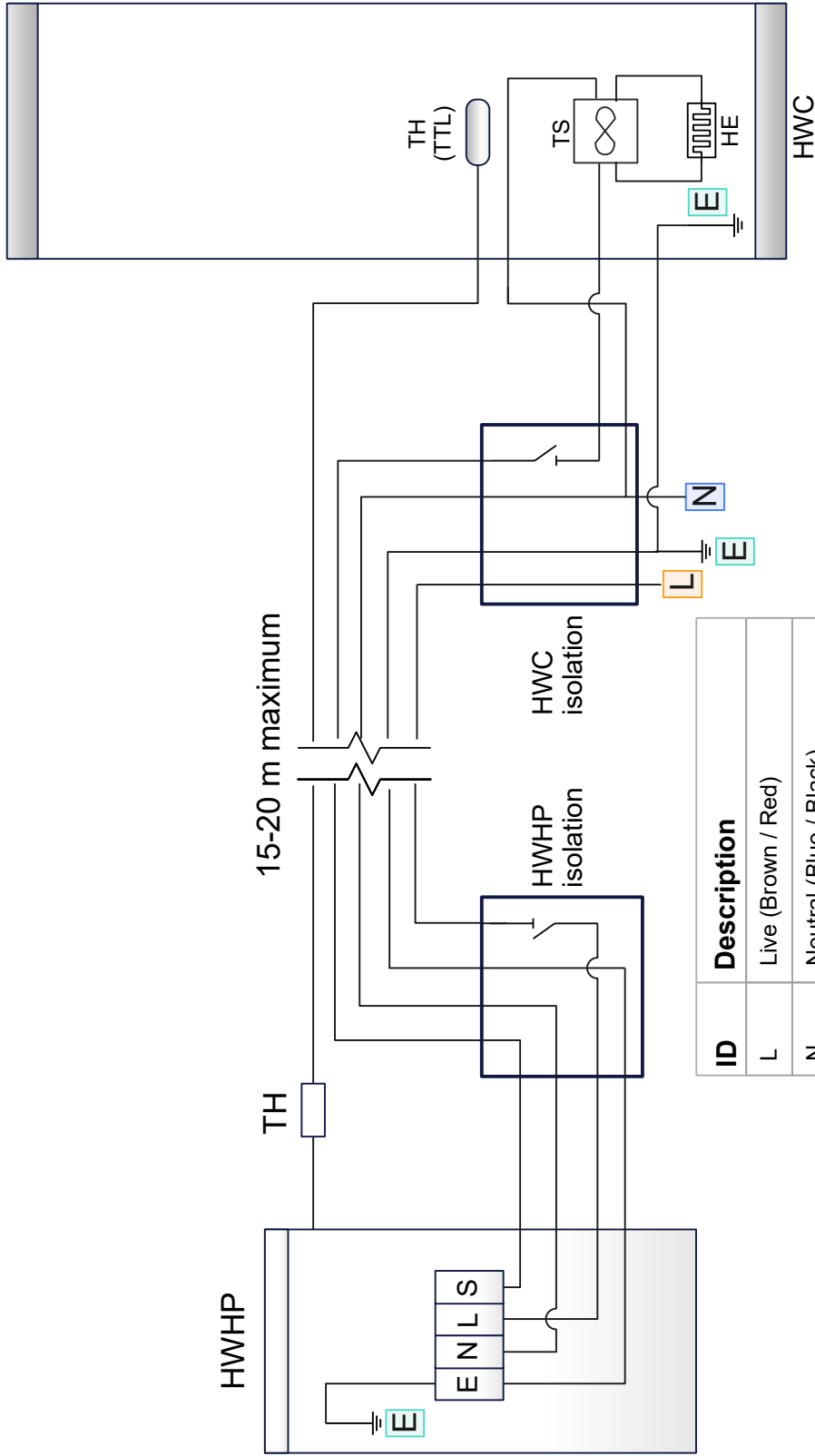

| ID   | Description                       |
|------|-----------------------------------|
| L    | Live (Brown / Red)                |
| N    | Neutral (Blue / Black)            |
| E    | Earth (Green with Yellow stripes) |
| S    | White (switched element)          |
| TS   | Thermostat                        |
| HE   | Heating element                   |
| HWHP | Hot water heat pump               |
| HWC  | Hot water cylinder                |
| TH   | Thermistor harness                |

**Note:**  
Cylinder Earth and Neutral must be on the same circuit as the heat pump

# Commissioning



Commissioning, filling and draining must only be carried out by an authorised person. Make sure the cylinder is full of water before energising the system. Failing to do this can cause irreparable damage to the element and sensors.

## Filling the system and air bleed

1. Ensure all connections are tight and the heat pump isolation valves on the hot water cylinder are closed.
2. Open hot water tap at the sink.
3. Open the cold water isolation valve to the system. Allow the system to fill and the air to bleed through the tap.
4. Turn off the hot tap at the sink when water flows freely without any air bubbles or air bursts.
5. Check for leaks at and around the hot water cylinder and associated valves, and rectify if detected.
6. Open the heat pump isolation valve at the bottom of the hot water cylinder. Crack the fitting at the top heat pump isolation valve to bleed air until water starts to flow (use a bucket if necessary).
7. The heat pump unit is now fully bled. Open the top isolating valve.
8. Turn on the heat pump unit AND the hot water cylinder isolating switch. After approx. 10 seconds the heat pump unit display will show "STANDARD 60C". If this is the desired mode, then nothing needs to be done. Alternatively another mode can be selected.

If the display does not light up when the unit is switched on, check that the breaker is on, and power is available at the heat pump. Remediate as necessary and retry.

9. The heat pump unit will wait 5 mins before the compressor starts. Alternatively, press and hold the two rightmost buttons (arrow keys) on the display simultaneously to override the starting delay.
10. The heat pump unit will heat the internal condenser to 50 °C and then the circulating pump will start. This normally takes 5-10 minutes. After this time the hot water pipe supplying water from the heat pump to the cylinder should be hot to the touch. Wait an additional 5 minutes to ensure the heat pump is delivering water constantly at the set point temperature.
11. Bleed any remaining air from the TPR.

## To turn off the system

It may be necessary to turn off the system after installation and commissioning, for example during building activities or if the premises are vacant.

1. Switch off the electricity supply at the isolating switch to the system.
2. Close the water isolation valve at the inlet to the water heater.
3. Drain if there is a risk of freezing.

## To drain the system

1. Turn off the system as above.
2. Open all the hot water taps.
3. Gently open the TPR valve, this will relieve pressure in the system.
4. Remove the cover on the side of the heat pump unit. Undo the two swivel fittings at the inlet and outlet of the heat pump to allow water to drain from the condenser of the heat pump unit.
5. Lock the heat pump isolator to prevent the system from accidentally being turned on when drained.
6. Open the drain valve—make sure no damage/injury will occur from discharged water.
7. Open the TPR valve again. This allows air into the system and will result in the cylinder draining.

## Controller sequence

When connected to mains power for the first time the back light of the controller will come on, and after a couple of seconds the Rinnai logo will appear. The controller will then default to showing 'Standard' operation which is the factory preset mode of operation. If no buttons are pressed after 30 seconds the controller will go into standby (nothing displayed on the controller). Pressing any button on the controller will turn the controller back on.



For further detail on the controller and setup, refer pages 30-31.

Approximately ten to fifteen minutes after the system has been powered, and before leaving ensure the:

- Cylinder is full of water and thermostat is set to 70 °C
- Heat pump is connected correctly
- Hot water return from the heat pump is warm—verifying correct pipe connections
- Compressor and fan are operating
- Display is operating with no fault conditions
- Cylinder temperature sensor is installed correctly and connected to the controller cable
- Controller cable connected to the heat pump - S8 fault will occur if not connected
- Heat pump supply and return piping is fully insulated
- System has been purged of air
- Water strainer has been fitted to the heat pump inlet line
- Correct accessory connections have been installed
- Pipework DN15



If the system cannot be made to perform correctly please contact Rinnai.

## Customer handover



Explain to the customer about the use, care, service and maintenance of the system, and ensure they understand the instructions. Make sure you leave this installation guide with them as it contains important information about their system.

# Error / warning codes

When the system encounters an event, a code will display on the screen, and the unit will beep once every 5 seconds. The most common errors are electrical connection faults, T1 and S8 faults, for which rectification actions are detailed below. If other fault codes are detected contact Rinnai for advice and additional troubleshooting actions.



During legionella disinfection, and when in defrost, 'L' and 'D' will appear on the main display—these are not fault codes.

| Code   | Event / fault description                      | Possible cause   | Action   |
|--|--|--|--|
| -  | Unit does not turn on                          | No power to cylinder   | Check connection to mains power, and check the cylinder isolator is on.<br>Check circuit breaker in distribution board is on.  |
|  |  | Blown fuse   | Check PCB fuse for continuity. Replace if faulty.  |
|  |  | Display not visible  | Timeout has occurred, press OK. If the system has been set to an operation mode, then it is locked. To unlock press and hold the OK button for 3-5 seconds. If still not visible, power cycle the unit.  |
|  |  |  |  |
| T1   | Condenser over temperature                     | Insufficient or zero water pressure                                    | Check the cylinder is filled with water and the inlet isolation valve is open.   |
|  |  | TTL not connected properly   | Check it has been installed correctly as per instructions.   |
| -  | Zero flow scenario                             | Air lock in supply return lines  | Check both heat pump isolation valves (on cylinder) are open. Manually purge supply/ return pipes as explained in installation procedure. Reset and retry. Use real-time view of the technician app to investigate.  |
| S8   | Lower cylinder temperature sensor fault        | Cylinder sensor not connected properly                                 | Check it has been installed correctly as per instructions.   |
| E2   | Primary electric backup relay fault            |  | Element is running when it should be off (i.e. standard / Eco 55 heating cycles). Check main PCB and replace if faulty.  |
| E4   | Startup check detects an error                 | Element >3kW (installation error), power surge, element faulty/shorted | An E4 fault will produce an audible notification and will leave the customer with no hot water unless the cylinder isolation switch is activated and the unit power reset. Operation will be HP only until the error has been fixed. Replace the element with a 3 kW one or less.<br>Check power connections and resistance on element, refer to service manual and use technician app to investigate. |
| L8   | Three consecutive legionella timeouts detected | No power to element  | Check power to the element and confirm if the cylinder thermostat is properly wired.   |
|  |  | Defective thermostat/ thermostat set point is too low                  | Check input and output of the thermostat and ensure thermostat set point is set to 70 °C or above.   |
|  |  | Element is burnt out   | Check element resistance, should be ~25 Ω  |
|  |  | E1/E3 faults   | Use the technician app to investigate event logs   |
| L8 is a warning indicator, the heat pump will operate as normal. |  |  |  |

For the below error codes, contact Rinnai for advice and additional troubleshooting actions.

| Fault code | Event / fault description                    | Possible cause  | Action   |
|------------|--|---|--|
| O1         | Real time clock fault, not reading correctly | Flat battery and power cut  | Replace the battery (not a user serviceable part).   |
| S1         | Ambient sensor fault                         | Sensor faulty / not detected  | Refer service manual troubleshooting   |
| S2         | Water inlet sensor fault                     | Sensor faulty / not detected  | Refer service manual troubleshooting   |
| S3         | Water outlet sensor fault                    | Sensor faulty / not detected  | Refer service manual troubleshooting   |
| S4         | Compressor discharge sensor fault            | Sensor faulty / not detected  | Refer service manual troubleshooting   |
| S5         | Condenser sensor fault                       | Sensor faulty / not detected  | Refer service manual troubleshooting   |
| S7         | Evaporator (pressure) sensor fault           | Sensor faulty / not detected  | Refer service manual troubleshooting   |
| T2         | Evaporator under temperature                 | Unit not defrosting, low refrigerant charge, evaporator blocked                               | Refer to service manual and use technician app to investigate. Visually look for wall clearance and any blockages. |
| T3         | Low super heat fault                         | Evaporator blocked, faulty sensor   | Refer to service manual and use technician app to investigate.   |
| T4         | Low water temperature fault                  | Low refrigerant charge, fan fault, inadequate wall clearance, water inlet temperature too low | Refer to service manual and use technician app to investigate. Visually look for wall clearance and any blockages. |
| T6         | Discharge over temperature                   | Low refrigerant charge, worn compressor, loose/faulty EEV coil                                | Visually look for blockages. Refer to service manual and use technician app to investigate.                        |
| F1         | Fan not rotating                             | Fan blade blocked, fan water damage   | Visually look for blockages. Refer to service manual and use technician app to investigate.                        |
| F2         | Fan over speed                               | Overspeed conditions (> 1000 rpm)   | Refer to service manual and use technician app to investigate.   |
| P1         | Pump is not rotating                         | Pump obstructed or jammed due to debris or ice  | Refer to service manual and use technician app to investigate.   |
| P2         | Pump over speed                              | Overspeed conditions (> 12400 rpm)  | Refer to service manual and use technician app to investigate.   |
| C1         | Compressor not running                       | Faulty capacitor, internal wiring, PCB sensor   | Refer to service manual and use technician app to investigate.   |

### T1 fault

A T1 fault on operation could indicate a no flow and overpressure fault. Ensure that the air vent is not blocked. A T1 could also indicate the cylinder temperature sensor is not mounted correctly. Do a manual reset by turning off the system then turning back on again.

#### Correct position

(air vent cap partially open)



#### Incorrect position

(vent cap closed)



# Storage and delivery temperatures

## Storage temperature

To meet the New Zealand Building Code requirement<sup>1</sup> to disinfect water for legionella bacteria, the system includes a built-in legionella disinfection cycle that operates in all modes. The heat pump heats the entire cylinder to above 60 °C once a week for one hour.



- The access cover to the element and the thermostat must only be removed by an electrician or other suitably qualified tradesperson.
- Thermostat settings must only be adjusted by an electrician or other suitably qualified tradesperson.

## Hot water temperatures

NZBC G12.3.6 states that “*Where hot water is provided to sanitary fixtures and sanitary appliances, used for personal hygiene, it must be delivered at a temperature that avoids the likelihood of scalding.*”

In order to prevent scalding the delivered hot water temperature at any sanitary fixture used for personal hygiene must meet:

- G12/AS1 6.14.1 a)
- G12/AS1 6.14.1 b)

Sanitary fixtures used for personal hygiene includes showers, baths, hand basins and bidets.

In kitchens and laundries, heated water must be delivered to fixtures and appliances at flow rates and temperatures which are adequate for the correct functioning of those fixtures and appliances. The temperature required may be greater than 50 °C.

To comply with these requirements, a temperature limiting device, such as a tempering or thermostatic mixing valve will be required on standard residential installations.

<sup>1</sup> Clause G12.3.9, Acceptable Solution G12/AS1 6.14.3

# Water quality

Water quality MUST:

1. Meet the Water Services (Drinking Water Standards for New Zealand) Regulations 2022 and the Aesthetic Values for Drinking Water Notice 2022, or the water standards as statutorily defined at the time; AND
2. Be within the limits shown in the table below.

Water quality outside these limits will void this warranty.

## Water quality and impurity limits

|  |              |                                  |                 |
|--|--------------|----------------------------------|-----------------|
| <b>TDS (Total Dissolved Solids)</b>                                | <600 mg/L    | <b>Manganese</b>                 | <0.01 mg/L      |
| <b>Total Hardness CaCO<sub>3</sub></b>                             | <200 mg/L    | <b>Sodium</b>                    | <150 mg/L       |
| <b>Alkalinity</b>  | 150-200 mg/L | <b>Iron</b>                      | <0.1 mg/L       |
| <b>Dissolved (free) CO<sub>2</sub></b>                             | <25 mg/L     | <b>Sulphate</b>                  | <100 mg/L       |
| <b>pH</b>  | 6.8-7.5      | <b>Nitrate</b>                   | <11 mg/L        |
| <b>Chlorides</b>   | <150 mg/L    | <b>Alkalinity/Sulphate ratio</b> | >1              |
| <b>Free Chlorine</b>   | <1 mg/L      | <b>LSI<sup>1</sup></b>           | -1.0-0.8 @20 °C |
| <sup>1</sup> Langelier Saturation index—scaling potential of water |              |                                  |                 |

## Water quality warranty guidelines

### Filtration

Where there is discolouration, debris, or silt present in the water, an inline filter must be fitted into the water supply to protect the copper in the HydraHeat from corrosion, and wear on the circulating pump. Particulates and deposits in hot water systems are corrosive to copper and stainless steel and can lead to premature pitting. The filters must be periodically replaced to maintain the integrity of the system.

### Stagnation

Leaving water stagnant in the system will promote corrosion. It is recommended that systems, if not in use, are flushed on an eight week cycle.

### Bore and tank water

Bore and tank water supplies should be considered to be corrosive and should be tested prior to using the system. Bore and tank water must meet the water quality parameters stated in the above table.

# Controller interface

The HydraHeat controller uses a compact OLED display with three capacitive touch buttons to enable easy access to the operation menus. When a button is pressed there will be an audible beep.



## Home screen and navigation

To access the home screen press OK for approximately 3-5 seconds. The screen will show the current operating mode, which is set to 'Standard' by default.

The display will automatically turn off after 30 seconds, but can be reactivated again by pressing any of the buttons.

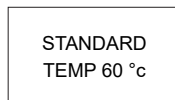

- MODES
- SET DAY / TIME
- SET TIMER
- FACTORY RESET



Down button: Scrolls through the different menu options



OK button: Selects the option



Back button: Returns to the previous screen



## Operation modes

Press the down button to cycle through the screens to select the mode of operation required. Select OK to confirm. Once the mode is selected, the screen will display the modes in the order shown below.

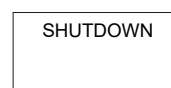
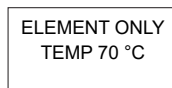
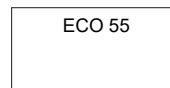
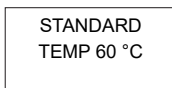
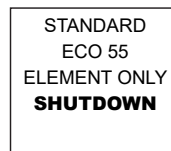
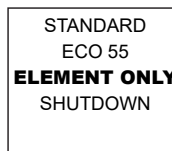
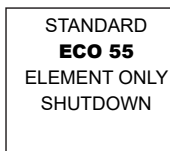
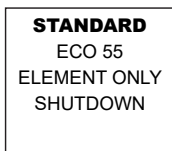

## Day and time

- MODES
- SET DAY / TIME**
- SET TIMER
- FACTORY RESET

This only needs to be done during daylight savings, or if the factory set day and time settings are lost, for example if a 'Factory reset' has been done. The clock is a 24-hour clock.



Once in 'Set Day / Time' press and hold the down button to scroll through the day, hour, and minutes to edit, press OK to confirm selection at each stage.

## Set and forget timer

The timer can be used to lock out the system so it does not operate. Once set it will continue to operate at the programmed times until 'Timer Reset' is selected.

**Scenario:** Dave wants to reduce the operating noise of the system at night as it's located near a neighbouring boundary where bedrooms are located. He sets the system to go off from 10pm to 6am.

### How to set

1. Select 'SET TIMER', and press OK.
2. Press and hold the down button to scroll through the hours / minutes you want to edit, and press OK.
3. Once the time is set, select the mode of operation by using the down button, press OK to confirm.

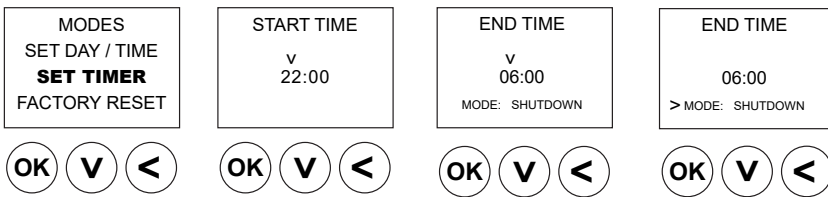

When timers are activated, they can prevent the system from operating, which may lead to insufficient hot water or a complete lack of hot water. The impact will depend on the amount of hot water being used.

### Reset timer

1. Select 'SET TIMER', and press OK.
2. Use the down button to select 'RESET TIMER', and press OK.
3. Confirm 'YES', and press OK.

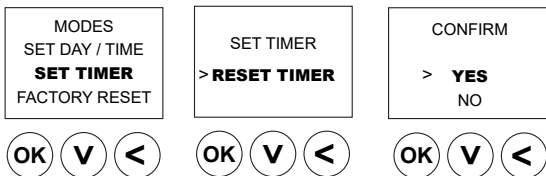

### Factory reset

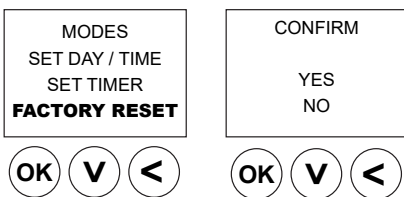

A factory reset clears the date, time, and any set timers, retaining only the default 'STANDARD' mode setting. After a factory reset, you will need to reconfigure the date and time for the timer functionality to work properly.

### Locking / Unlocking the screen

To lock the screen press and hold both the OK and Back buttons for more than five seconds. The screen will display 'Locked' and then return to the current operation mode after a short delay. To unlock and access the main menu, press and hold the same two buttons again.

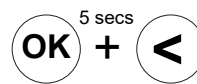

# Appendix: Commercial concept sketch



This high level sketch is for illustrative purposes only and does not show all components required for a complete system. For ring main installations please contact our **commercial team** for a detailed plumbing schematic.

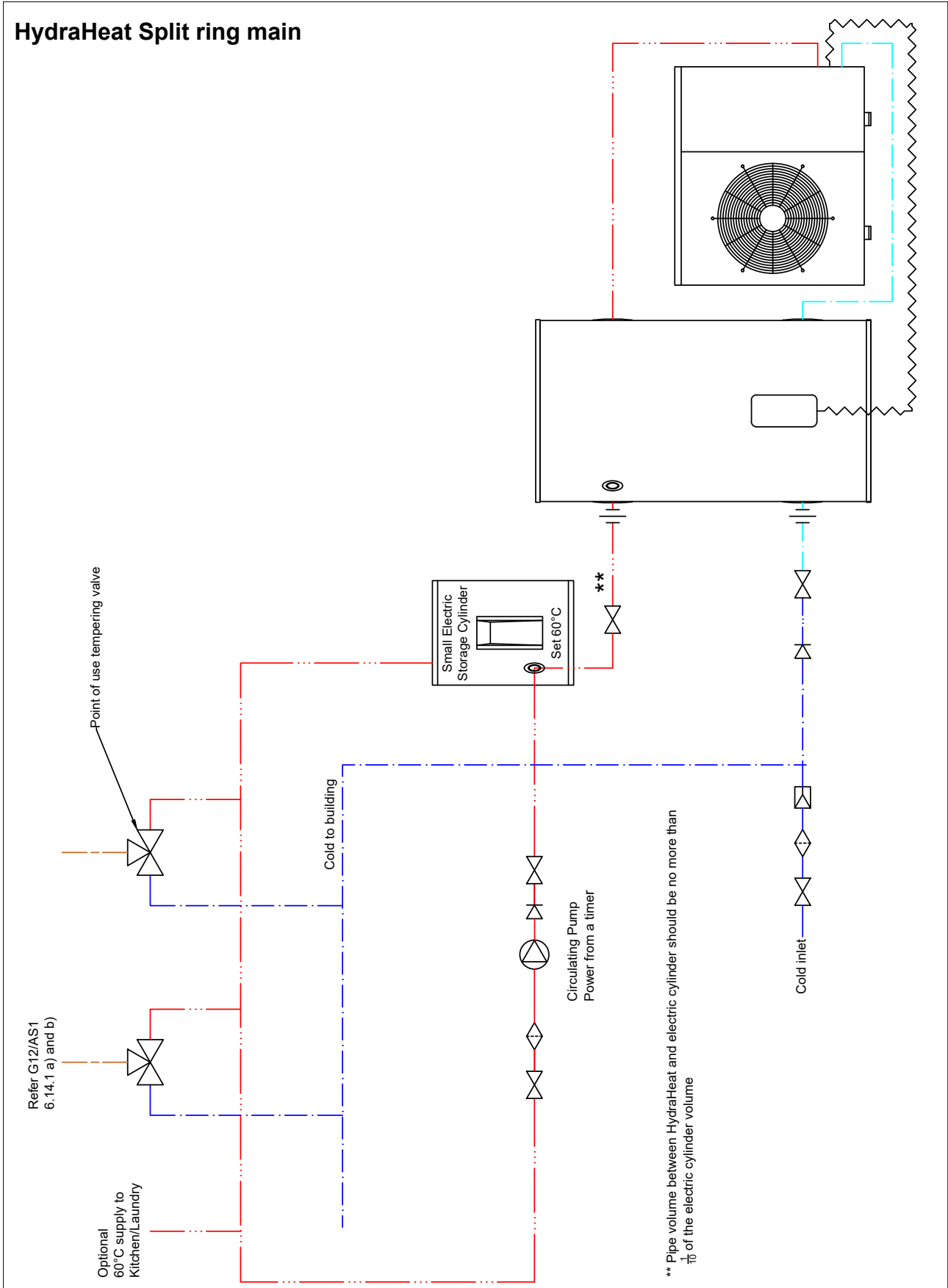

# Notes

# Notes

# Notes

**Rinnai.co.nz**

Tel: 0800 746 624

<http://www.youtube.com/rinnainz>

<http://facebook.com/rinnainz>

Rinnai HydraHeat Split installation guide 31452-J