



Mains Pressure Indoor/Outdoor Enamel Cylinders

Owner and installer guide

Rinnai

Important

Cylinders shall be installed in accordance with:

- Manufacturer's installation instructions
- Current AS/NZS 3000, AS/NZS 3500, and G12/AS1

Installation, servicing, repair, and removal shall be carried out only by authorised personnel.

Not suitable as a spa or swimming pool heater.

- Owner, please retain this guide for future reference
- Installer, please leave this guide with the owner

Warning

Improper installation, adjustment, alteration, service and maintenance can cause property damage, personal injury or loss of life.

This appliance is not to be used by persons (including children) with reduced physical, sensory or mental capabilities, or lack of experience and knowledge, unless they have been given supervision or instruction.

For more information about buying, using, and servicing of Rinnai appliances call: 0800 RINNAI (0800 746 624).

Rinnai New Zealand Limited
105 Pavilion Drive, Mangere, Auckland
PO Box 53177, Auckland Airport, Auckland 2150

Phone: (09) 257-3800
Email: info@rinnai.co.nz
Web: rinnai.co.nz
[youtube.com/rinnainz](https://www.youtube.com/rinnainz)
[facebook.com/rinnainz](https://www.facebook.com/rinnainz)

Contents

About your cylinder.....	4
Maintenance and servicing.....	5
Troubleshooting.....	6

Installation

Specification summary.....	8
Dimensions.....	9
Plumbing arrangement.....	10
Storage and delivery temperatures.....	11
Water quality.....	12
Electrical supply and connections.....	13
Valves and fittings.....	14
Commissioning.....	15
Limited Warranty.....	16
Proof of purchase.....	19
Installer details.....	19

About your cylinder

Water is heated by an electric element located in the cylinder. The temperature of the water is controlled by an automatic thermostat that is set by your installer, usually to 65 °C.

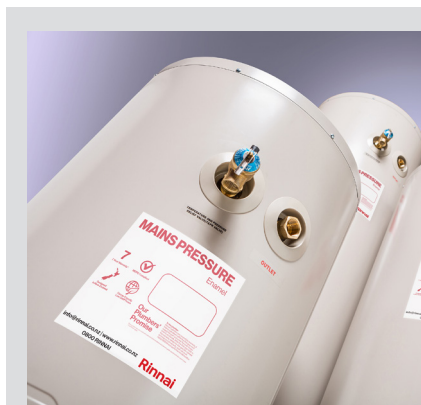

Important

Where there is potential of damage occurring from a leaking system, a suitably drained safe tray is fitted as per AS/NZS 3500.4 5.4 and G12/AS1 6.11.3—the person doing the installation is responsible for this.



Safety messages

- **Element cover**
Do not remove the element cover as this will expose 230 V wiring and must only be removed by an authorised person.
- **Thermostat setting**
Must only be adjusted by an electrician or other suitably qualified tradesperson.
- **Damaged components**
If any component is damaged, it must be replaced by an authorised person using Rinnai replacement parts.
- **Child supervision**
Children should be supervised to ensure they do not play with any part of the hot water system.
- **Hot pipe work**
Care should be taken not to touch the pipe work from the cylinder as this could be very hot.

Safety devices

Your cylinder is fitted with a:

- Temperature & Pressure and Relief (TPR) valve that ensures the water remains at a safe pressure and temperature.

- Automatic thermostat to maintain water temperature.
- Temperature override cutout for heating element.

The operation of the thermal cutout can indicate a dangerous situation. Do not reset the thermal cutout until the water heater has been serviced by a qualified person.

Do not operate the system unless all the safety devices are fitted and are in working order. It is also important that you do not tamper or remove any of these devices.

Cylinder thermostat setting

To meet the New Zealand Building Code requirement¹ to disinfect water for legionella bacteria², the cylinder thermostat has been set to 65 °C.

Hydrogen gas

If hot water is not used for two weeks or more, a quantity of hydrogen gas, which is highly flammable, may accumulate in the cylinder. To dissipate safely, it is recommended a hot tap (non-electrical) be turned on for two minutes at a sink, basin or bath. During this procedure there must be no smoking, open flame, or any other appliance operating nearby.

Turning the cylinder on/off

If you plan to be away for a few nights we suggest you leave the system switched on. If it is necessary to switch it off, when switching back on, remember that the cylinder will take time to heat back up again.

Draining and filling the system

This normally occurs during installation or servicing and must be carried out by an authorised person.

Installation by a licensed tradesperson

Only a licensed tradesperson can install, adjust, maintain, and service this water heater. Any work carried out by a non-licensed tradesperson is illegal and will void any warranty.

¹ Clause G12.3.9, Acceptable Solution G12/AS1 6.14.3

² Legionella is a bacterium that can cause Legionnaires' disease—a severe form of pneumonia

Maintenance and servicing

Hot water systems require regular maintenance and servicing. To ensure longevity of your cylinder we recommend the following.

Period	What needs to be done
Every six months	TPR (temperature & pressure relief) operate the easing gear
Year five	Inspection and service the entire hot water system, including element*
Every 24 months after year five	Inspection and service the entire hot water system, including element*

* In hard water areas the element(s) must be periodically descaled. To do this the cylinder must be drained and the element(s) removed

TPR valve

Depending on the model the valve is located near the top, or on top of the cylinder. It is essential for safe operation. The TPR valve works by automatically venting hot water if the temperature or pressure of the water in the cylinder gets too high.

Every six months operate the easing gear to remove lime deposits and to check that it is not blocked. As this will discharge hot water, ensure no one is near the drain line.

WARNING Failure to operate the relief valve easing gear at least once every six months may result in the water heater exploding. Continuous leakage of water from the valve may indicate a problem. It is important that you raise and lower the easing gear gently.

During the operation, if the valve does not discharge water when the easing gear is lifted, or does not seal again when closed, arrange for an authorised person to come and inspect the system immediately.



During servicing of your cylinder the TPR valve needs to be checked and/or replaced. This needs to be done by an authorised person at intervals not exceeding five years, or more frequently in areas where the water is classified as hard.

A TPR valve must not be replaced with one that has a higher pressure rating than that specified for the cylinder.

Anodes in enamel tanks

Storage tanks manufactured from metal can be susceptible to corrosion. The combined effects

of water pressure, temperature and water chemistry can create an aggressive environment for corrosion of some materials. For this reason anodes are placed in enamel tanks so as to corrode first. Anodes should be changed every five years or more frequently in hard or aggressive water areas.

Maintenance and servicing

Rinnai has a maintenance, service, and spare parts network with personnel who are fully trained and equipped to give the best advice on your Rinnai product. Regular maintenance and servicing is not covered by the Rinnai warranty.

For help locating a service person in your area call 0800 RINNAI (0800 746 624).

TPR position - top of cylinder



How to operate the easing gear



Troubleshooting

Do not attempt to carry out any work other than that mentioned in this troubleshooting section. If you have any other faults or problems, please contact your installer, or contact Rinnai.

Problem	Possible solution
Lack of hot water or no hot water	<p>Is there electricity supply to the cylinder?</p> <p>Check that the isolating switch marked 'hot water' or 'water heater', at the meter box, is switched on. Also check any isolating switches near the water heater are switched on.</p> <p>Check the fuse or circuit breaker marked 'hot water' or 'water heater' at the meter box. Repeated failure of the fuse or tripping of the circuit breaker indicates a fault, which must be investigated by an authorised tradesperson.</p> <p>Most hot water cylinders are controlled at peak times by your electricity supplier via a ripple relay. Contact your electricity supplier to determine if there have been any issues with the power supply.</p>
Lack of hot water or no hot water	<p>Are you using more hot water than you think?</p> <p>Often you don't realise how much water is actually being used. This applies especially when showering. Typical flow rates for showers is approximately 8-10 litres per minute. Conduct a simple experiment by placing a measured bucket under your shower for ten seconds and multiply by six to determine the amount of water produced over a minute. If your result is significantly more than the rates mentioned you may want to consider installing a low flow shower rose—available at all good plumbing stores.</p>
Lack of hot water or no hot water	<p>Cold water relief valve discharging continuously?</p> <p>It is normal for the cold water relief valve to discharge a small quantity of water through the drain line. If water is discharging continuously there may be a fault with one of the valves, contact the installer to discuss.</p>
Water is too hot	<p>If possible check the temperature of the water coming out of a hot water tap with a thermometer. If it is higher than 50 °C then this indicates a problem with your system—contact an electrician for advice.</p>
High electricity bills	<p>If you think your electricity bill is too high, investigate the following:</p> <ul style="list-style-type: none">• Has your electricity tariff changed?• Is your cold water relief valve discharging continuously?• Are you using more hot water than normal?• Has there been any leaking hot water pipes, or taps?

Installation

Installation, servicing, repair, and removal shall be carried out only by authorised personnel.

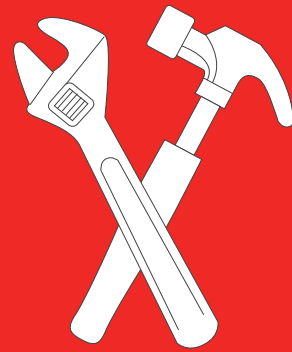

Specification summary



Suitability

- Indoor and outdoor installations
- Mains and low pressure systems
- Residential and commercial water heating applications
- Right hand plumbing connections (90, 135, 180 L)
- Left or right hand plumbing connections (215, 275, 340 L)

System should be located and arranged so as to achieve the closest proximity to water draw off points.

Not suitable as a spa or swimming pool heater, or for hydronic applications. Water quality must meet the parameters stated on p.18.

Construction	High quality glass lined (vitreous enamel) inner cylinder. Sturdy corrosion resistant outer casing, and high density expanded polyurethane foam insulation.		
Connections	Hot and cold water connections ¾ " (20 mm)		
Elements	cTech element positioned at the bottom of the cylinder		
Pressure limiting valve	500 kPa (approx.) all models		
Cold water pressure relief valve	700 kPa (approx.) all models		
Thermostat	Setting is between 60-75 °C. Maximum thermostat setting, in order to maintain the warranty is 75 °C.		
TPR	Rating of TPR supplied with the cylinder is 10 kW / 850 kPa, 99 °C		
Protection against water	IPX4		
Weights (empty / full)	90 L	44 kg	134 kg
	135 L	56 kg	191 kg
	180 L	71 kg	251 kg
	215 L	83 kg	298 kg
	275 L	87 kg	364 kg
	340 L	101 kg	441 kg

Cylinder recovery times

Based on a thermostat temperature setting of 60 °C and an incoming water temperature of 15 °C.

Model	Heat up time	Recovery rate
90 L 2 kW	2 hrs 38 mins	34.3 L/h
90 L 3 kW	1 hr 45 mins	51.6 L/h
135 L 2 kW	3 hrs 56 mins	34.6 L/h
135 L 3 kW	2 hrs 37 mins	51.3 L/h
180 L 2 kW	5 hrs 15 mins	34.3 L/h
180 L 3 kW	3 hrs 30 mins	51.4 L/h
215 3.6 kW	3 hrs 29 mins	61.8 L/h
275 L 3.6 kW	4 hrs 28 mins	61.7 L/h
340 L 3.6 kW	5 hrs 31 mins	61.7 L/h

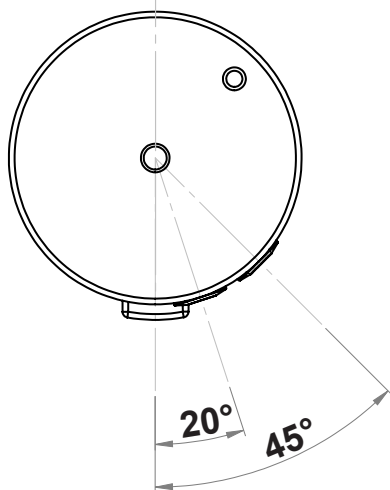
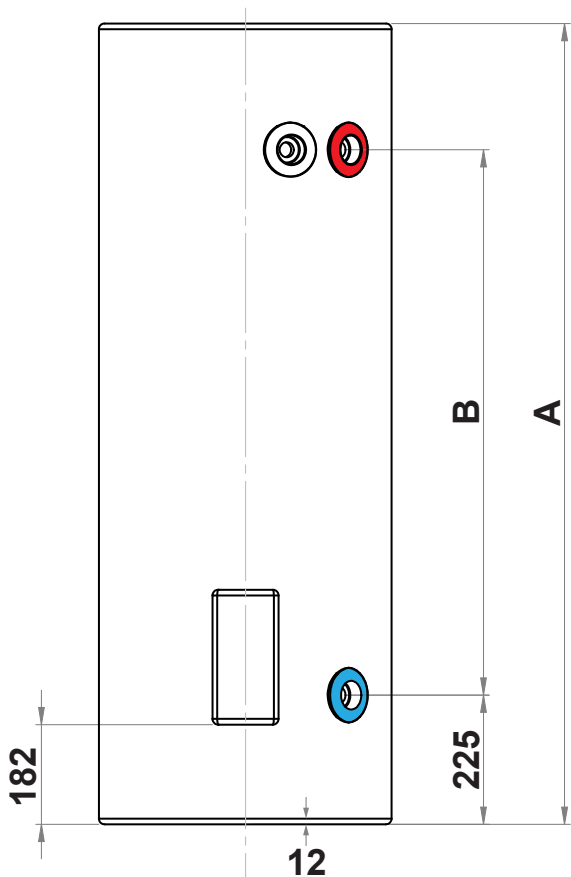

Model	Diam.(mm)	A (mm)	B (mm)
90 L	Ø 488	995	550
135 L	Ø 488	1395	950
180 L	Ø 488	1790	1345

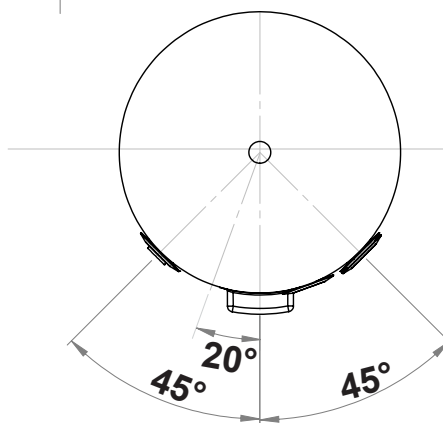
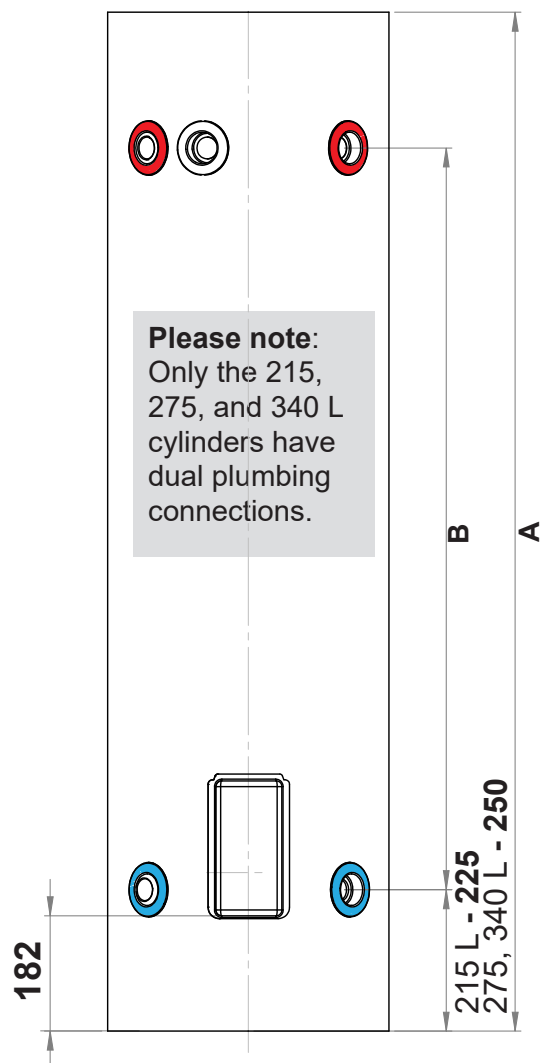

Model	Diam.(mm)	A (mm)	B (mm)
215 L	Ø 515	1825	1375
275 L	Ø 685	1275	725
340 L	Ø 685	1520	970

Plumbing arrangement

The cylinder component of the system must be installed in accordance with G12/AS1, and AS/NZS 3500.4. For service and maintenance, please allow sufficient room for access to covers and valves. All hot water pipe work should be insulated with polythene foam or equivalent insulation to optimise performance and energy efficiency. This includes all water fittings.

All hot water supply parts must comply with AS/NZS 3500.4 and G12/AS1.



- The valve or drain valve outlet pipe must not be sealed or blocked.
- Valves with pressure ratings other than those listed in this manual must not be used
- A discharge pipe connected to the pressure relief device is to be installed in a continually downwards direction and in a frost free environment.

For an appliance intended to be permanently connected to the water mains and not connected by a hose set.

Plumbing arrangement for a mains pressure cylinder

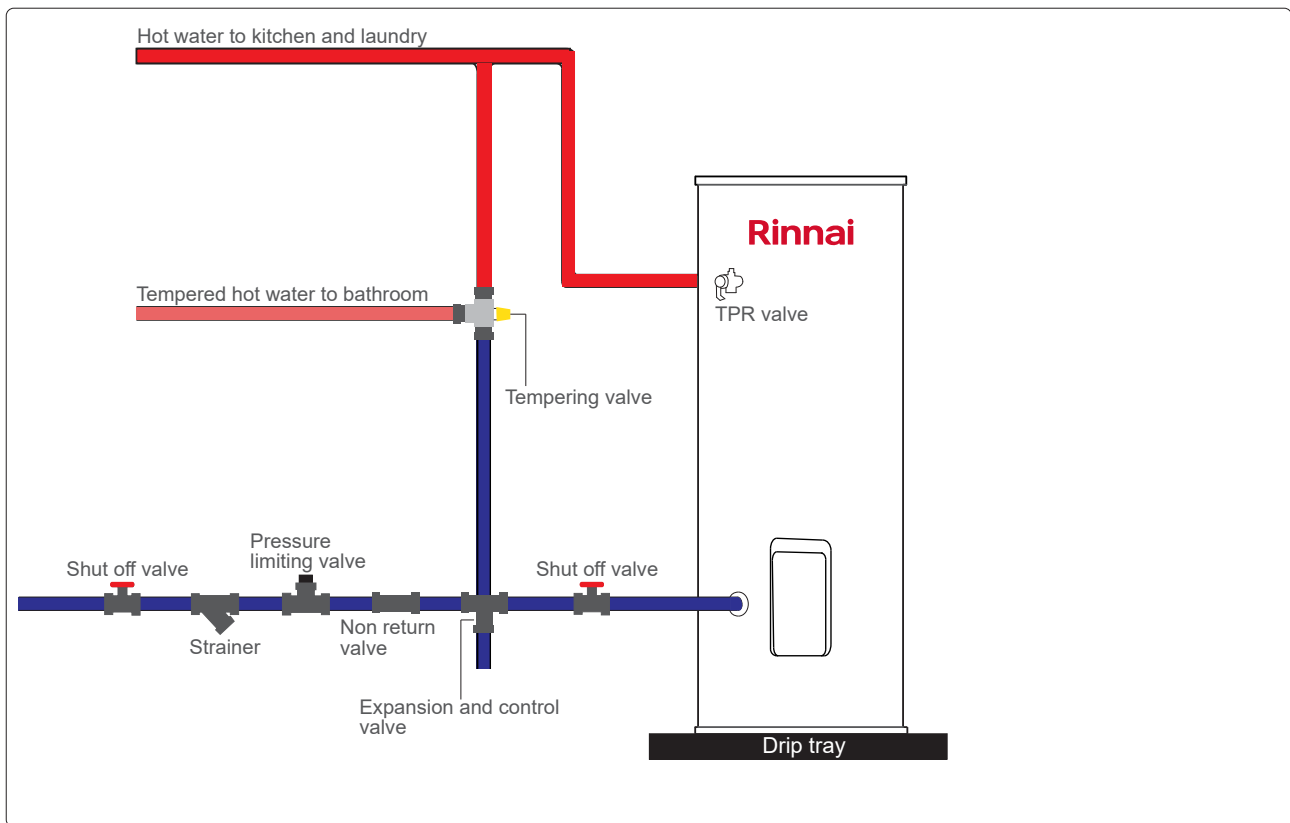

Base requirements

Cylinders must be installed in an upright position on a level, stable, and water impervious base. The base must be capable of withstanding the weight of a full system. The structure must not shift.

Consideration should be given to location of the cylinder and base to prevent water ponding on the base and installations should allow water to drain and dry. Ensure the storage cylinder does not stand on permanently wet surfaces.

Where there is potential of damage occurring from a leaking system, a suitably drained safe tray is fitted as per AS/NZS 3500.4 5.4 and G12/AS1 6.11.3.

Drain valves

In accordance with AS/NZS 3500.4 5.11.3, drain lines from temperature / pressure-relief valves, expansion control valves and tundishes shall be installed and located so as not to cause a nuisance, is readily discernible and incurs no risk or damage to the building (including slabs and footings) or injury to persons. Discharging drain lines or TPR relief lines onto the base is not advised as over time water discharge can adversely affect the cylinder.

Seismic constraint

NZBC B1.3.2 requires building elements (including *storage water* heaters) to be adequately supported including support against earthquake forces.

Each of the following is an acceptable solution to B1.3.2 for a cylinder installation.

	Acceptable solution	Clause or referenced standard	Section of referenced document
1	G12/AS1	6.11.4 Structural Support: Figure 14	
2	G12/AS3	AS/NZS 3500.4:2021: Figure 5.5.4	
3	G12/AS3	AS/NZS 3500.4:2021: Section 5.5.4	NZS 4607, Section 202: Fig.1 / Table 1

Pipe work

It is the installer's responsibility to adequately size the distribution pipe work in a property to ensure sufficient performance from all outlet fittings. Water pipe sizing should be performed in accordance with AS/NZS 3500.4 and/or G12/AS1. Pipe sizing and valve selection must be performed to allow for the water supply pressure.

A drain off tap or line must be fitted to the inlet of the water heater.

All hot water pipe work should be insulated with polythene foam or equivalent insulation to optimise performance and energy efficiency.

DO NOT drill anything into the water heater, this could damage critical components and cause corrosion.

TPR valve (850 kPa, 99 °C, 10 kW)

The supplied TPR valve must be installed to ensure safe operation. Failure to do so can potentially cause injury and damage the unit.

The TPR valve must be fitted with a drain pipe to direct any water discharged to a visible point outside the property. The drain pipe must have a continuous fall and be at least the same size as the TPR valve outlet (½ "BSP). Where the drain pipe exceeds three metres in length it is recommended an air break be provided within 300 mm of the TPR valve outlet. Where an air break is used it is recommended that the pipe size after the air break be increased to one size larger than the TPR valve. It must also be protected from freezing conditions.

Storage and delivery temperatures

Storage temperature

To meet the New Zealand Building Code requirement¹ to disinfect water for legionella bacteria, the cylinder thermostat has been preset to 65 °C.



WARNING

- The access cover to the element and the thermostat must only be removed by an electrician or other suitable qualified tradesperson.
- Thermostat settings must only be adjusted by an electrician or other suitably qualified tradesperson.

Hot water temperatures

NZBC G12.3.6 states that “*Where hot water is provided to sanitary fixtures and sanitary appliances, used for personal hygiene, it must be delivered at a temperature that avoids the likelihood of scalding.*”

In order to prevent scalding the delivered hot water temperature at any sanitary fixture used for personal hygiene shall not exceed:

- 45°C for early childhood centres, schools, aged care, institutions for people with psychiatric or physical disabilities, hospitals; and
- 50°C for all other buildings

Sanitary fixtures used for personal hygiene includes showers, baths, hand basins and bidets.

In kitchens and laundries, heated water must be delivered to fixtures and appliances at flow rates and temperatures which are adequate for the correct functioning of those fixtures and appliances. The temperature required may be greater than 50°C.

To comply with these requirements, a temperature limiting device, such as a tempering or thermostatic mixing valve will be required on standard residential installations.

¹ Clause G12.3.9, Acceptable Solution G12/AS1 6.14.3

Electrical supply and connections

The electrical connection must be carried out by a qualified person in accordance with NZ Electrical Regulations. The water heater must have the heating element connected to an independent, fused, AC 230 V 50 Hz power supply with an isolating switch installed at the switch board. Disconnect all power prior to installation and commissioning.

- The water heater must be filled with water prior to connection to the power supply
- Household wiring to the heater must be capable of withstanding the appliance load
- Fixed wiring must be protected from contact with the internal hot surface of the water heater

Electrical access is via a hole in the element cover for mounting with an approved electrical conduit gland. For entry to the element cover remove the two fixing screws.

Connect all LIVE, NEUTRAL and EARTH wires in accordance with the wiring diagram. Inspect and ensure all wiring links are secure prior to fixing the access cover and turning the power on.

To ensure the over-temperature and energy cutout is set press the 'reset' button on the thermostat.

The appliance is intended to be connected to cables of fixed wiring, refer table below.

Single element wiring diagram

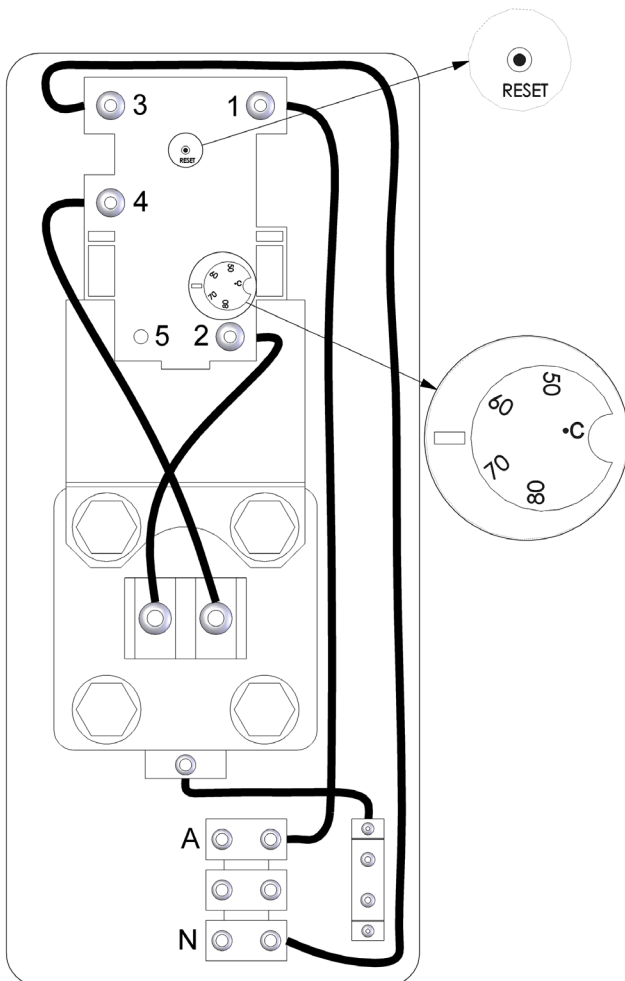

Cylinder element rating	Recommended fixed wire cable
2 kW	1-4 mm ²
3 kW	1.5-4 mm ²
3.6 kW	2.5-4 mm ²

Valves and fittings

Valves with pressure ratings other than those listed in this manual must not be used.

Valves and fittings supplied with the cylinder

Valves and fittings supplied with the water heater are placed in the Styrofoam packaging during transit. The following valves and fittings are supplied:

- A combined Temperature and Pressure Relief Valve (TPR), this is a safety device and it is mandatory that it is fitted to the top of the cylinder by the installer in all installations.
- Two brass plugs to plug the unused hot and cold connections (215, 275, 340 L models).
- Four $\frac{3}{4}$ MF adaptors to assist with fitting plumbing connections.
- A reducing bush to enable fitting the $\frac{1}{2}$ " TPR valve connection to the $\frac{3}{4}$ " cylinder connection.
- Cable gland, tested for IPX4 rating compliance, for outdoor installations this must be used.

Installer to supply

- Cold water expansion control valve (ECV)—must be fitted
- Pressure limiting valve
- Stop cock and non-return valve, these are fitted to the cold water supply to the water heater (combination valves incorporating these functions are suitable)
- Temperature limiting device, such as a tempering valve, if required.

Commissioning

Commissioning and draining activities must be carried out by an authorised person.

To fill and turn on the water heater

1. Open all hot water taps in the house including the shower.
2. Open the cold water isolation valve to the water heater. Air will now be forced out of the taps.
3. Close each tap when the water runs freely without air bubbles.
4. Check all plumbing connections and pipe work for water leaks.
5. Switch on the electric power supply.

To turn off the water heater

It may be necessary to turn off a water heater after installation and commissioning, for example during building activities or if the premises are vacant.

1. Switch off the electricity supply at the isolating switch to the water heater.
2. Close the cold water isolation valve at the inlet to the water heater.

To drain the water heater

1. Turn off the water heater as above.
2. Close all the hot water taps.
3. Gently operate the TPR valve release, this will relieve the pressure in the water heater.
4. Open the drain valve—make sure no damage will occur from discharged water.
5. Operate the TPR valve again. This allows air into the water heater and will result in the water draining.

Limited Warranty - Main Pressure Indoor/Outdoor Cylinders



Rinnai Main Pressure Indoor/Outdoor Cylinder warranty summary

	Residential	Commercial
Cylinder only	7 years	3 years
Labour	5 years	1 year
All other parts¹		
Parts	1 year	1 year
Labour	1 year	1 year

All terms of the warranty are effective from the first date of installation. Proof of installation will be required. Where the date of installation is not known or cannot be proven, the warranty will be based on the date of manufacture. Any warranty claim must be made within a reasonable time of discovery of the potential fault or defect.

¹ All other parts include, but are not limited to; sensors, thermostats, valves, electric heating elements, anodes.

General warranty terms

Rinnai reserves the right to make modifications and change specifications and its parts without notice.

For the purposes of the Consumer Guarantees Act 1993, Rinnai only guarantees the availability of repair facilities and spare parts for the express warranty periods recorded in the Rinnai warranty summary table.

If the Rinnai cylinder is being acquired for personal, domestic or household use*, this warranty does not limit any consumer rights or guarantees that may apply under the Consumer Guarantees Act 1993. If the product is being acquired for the purposes of a business, the provisions of the Consumer Guarantees Act 1993 do not apply and no other warranties (either express or implied by law), apart from those stated in this warranty, apply.

*A residential application is defined as an installation where the water heater, with the thermostat set at 75 °C and below, delivers hot water to a single family dwelling, not used for commercial purposes. Examples where a residential dwelling is used for commercial purposes: hair salon, catering kitchen, communal care facility etc. These installations would be considered commercial applications. An exception would be an accommodation business such as a motel, where the water heater serves the equivalent of a single family dwelling, this would be a residential application.

Warranty terms and conditions

- All terms of this warranty are effective from the date of first installation. The attending service person reserves the right to verify this date.
- All Rinnai appliances must be installed, commissioned, serviced, repaired and removed in accordance with the manufacturer's instructions, local regulations, and municipal building codes by persons authorised by local regulations to do so.
- All appliances must be operated and maintained in accordance with the manufacturer's operating instructions.
- This warranty applies only to the components supplied by Rinnai. It does not apply to components supplied by others, such as, isolating valves, electrical switches, pipe work, electrical cables, fuses, but not limited to these.

- Where the appliance has not been sited in accordance with the installation instructions or installed such that normal service access is difficult, a service charge will apply. If at the discretion of the attending service person the installation is deemed illegal or access is dangerous, service will be refused. Any work required to gain access to the appliance will be chargeable by the attending service person (for example, removal of walls, or the use of special equipment to move components, but not limited to these).
- Where a failed component is replaced under warranty, the balance of the original appliance warranty will remain effective. The replacement part or appliance does not carry a new warranty.
- Rinnai reserve the right to transfer functional components from defective appliances if they are suitable.
- Rinnai reserve the right to have installed product returned to the factory for inspection.
 - The decision of whether to repair or replace a faulty component of the cylinder is at the sole discretion of Rinnai.
 - Where Rinnai determines that the cylinder needs to be removed for repair, Rinnai may undertake such removal and may permanently replace the unit with a substitute unit that is in the reasonable opinion of Rinnai, in a better or equal condition to the defective unit.
- Where the cylinder is installed outside the metropolitan area or further than 40 km from an authorised repairer, travel costs shall be the owner's responsibility.

Warranty exclusions

The following exclusions may cause the warranty to become void and will result in a service charge and costs of parts (if required).

- Accidental damage, defects or failure caused by acts of nature (fire, wind, lightning, flood, storm, hail storm fallout), vandalism, earthquake, war, civil unrest, pests, animals, insects, or entry of foreign objects or matter into the product such as dirt, debris or moisture.
- Defects or failure due to environmental damage such as corrosion.
- Failure due to abuse or misuse, improper maintenance or improper storage.
- Failure due to incorrect or unauthorised installations.
- Failure or damage caused by alterations, service or repair work carried out by unauthorised personnel.
- Where the cylinder has failed directly or indirectly as a result of poor water quality outside the limits specified (refer next page).
- Where it is found that there is no fault with the appliance and the issue is related to the installation or is due to power failure.
- Subject to any statutory provisions to the contrary, Rinnai does not accept:
 - Liability for consequential damage or any incidental expenses resulting from any breach of the warranty.
 - Claims for damage to buildings or any other consequential loss either directly or indirectly due to leaks from the cylinder or any other faults.

Water quality

Water chemistry has a direct impact on hot water heaters, affecting corrosion protection measures, or causing scale buildup.

Water quality MUST:

1. Meet the Water Services (Drinking Water Standards for New Zealand) Regulations 2022 and the Aesthetic Values for Drinking Water Notice 2022, or the water standards as statutorily defined at the time; AND
2. Be within the limits shown in the table below.

Water quality outside these limits will void this warranty.

Water quality and impurity limits

TDS (Total Dissolved Solids)	<1000 mg/L	Chlorides	<250 mg/L
Total Hardness CaCO₃	<200 mg/L	Sodium	<200 mg/L
Alkalinity	<200 mg/L	Iron	<1 mg/L
Dissolved (free) CO₂	<25 mg/L	LSI¹	-1.0-0.8 @20 °C
pH	6.5-8.5		

¹ Langelier Saturation index — scaling potential of water

Water quality warranty guidelines

Stagnation

Leaving water stagnant in the system will promote corrosion. It is recommended that systems, if not in use, are flushed on an eight week cycle.

Purchase details

Record your purchase details below

	ATTACH YOUR PROOF OF PURCHASE HERE: 
Retailer: _____	
Retailer address: _____ _____	
Date of purchase: _____	
Product details: _____ _____ _____	
Please keep these details in a safe place for future reference.	Register your system online: www.rinnai.co.nz/register/ for service reminders, product updates, and special offers. You can unsubscribe at any time.

Installer details

Company name: _____	
Installer name: _____	
Address: _____ _____	
Phone: _____	Mobile: _____
Signed: _____	Date: _____

Rinnai.co.nz

Tel: 0800 746 624
<http://www.youtube.com/rinnainz>
<http://facebook.com/rinnainz>

20439-D