

The Rinnai logo is displayed in white text on a red rectangular background.

# Owner and installer guide

## Mains pressure coiled indoor stainless steel cylinders

### Models:

- HJ Cooper by Rinnai single coil thermosiphon cylinders (250 L , 300 L)
- HJ Cooper by Rinnai twin coil thermosiphon cylinders (250 L, 300 L)
- HJ Cooper by Rinnai single coil non-thermosiphon cylinders (190 L, 250 L, 300 L)



### Hello installer

Please leave this guide with the home owner as it contains important safety and warranty information.

## Important:

Cylinders shall be installed in accordance with:

- Manufacturer's installation instructions
- Current AS/NZS 3000, AS/NZS 3500, and G12/AS1
- Local regulations and municipal building codes

Installation, servicing and repair shall be carried out only by authorised personnel.

Not suitable as a spa or swimming pool heater, or for underfloor heating.

Owner, please retain this guide for future reference.  
Installer, please leave this guide with the owner.

### Warning

Improper installation, adjustment, alteration, service or maintenance can cause property damage, personal injury or loss of life.

The appliance is not to be used by persons (including children) with reduced physical, sensory or mental capabilities, or lack of experience and knowledge, unless they have been given supervision or instruction.

For more information about buying, using, and servicing of Rinnai appliances call: 0800 RINNAI (0800 746 624)

Rinnai New Zealand Limited  
105 Pavilion Drive, Mangere, Auckland  
PO Box 53177, Auckland Airport, Auckland 2150

Phone: (09) 257 3800  
Fax: (09) 257 3899  
Email: [info@rinnai.co.nz](mailto:info@rinnai.co.nz)  
Web: [www.rinnai.co.nz](http://www.rinnai.co.nz)  
[www.youtube.com/rinnainz](http://www.youtube.com/rinnainz)  
[www.facebook.com/rinnainz](http://www.facebook.com/rinnainz)

# contents:

About your cylinder .....	4
Maintenance and servicing .....	5
<b>Installation</b>	
Specification summary .....	7
Dimensions: Single coil thermosiphon.....	8
Dimensions: Twin coil thermosiphon.....	9
Dimensions: Single coil non-thermosiphon....	10
Plumbing setup .....	11
Storage and delivery temperatures.....	15
Wetback heat exchanger power input table ...	15
Water quality .....	16
Electrical supply and connections.....	17
Valves and fittings .....	18
Commissioning .....	18
Limited warranty .....	19
Warranty examples in the real-world .....	22
Proof of purchase .....	23
Installer details .....	23

# About your cylinder



## Important

All cylinders have the potential to leak water. To minimise damage to other areas of your home, ensure that your cylinder has been installed with a drip tray—the person doing the installation is responsible for this.



\* Refer to the warranty terms and conditions in this guide for more information.

## Safety messages

- **Element cover**  
Do not remove the element cover as this will expose 230 V wiring and must only be removed by an authorised person.
- **Thermostat setting**  
Must only be adjusted by an electrician or other suitably qualified tradesperson.
- **Damaged components**  
If any component is damaged, it must be replaced by an authorised person using Rinnai replacement parts.
- **Child supervision**  
Children should be supervised to ensure they do not play with any part of the hot water system.
- **Hot pipe work**  
Care should be taken not to touch the pipe work from the cylinder as this could be very hot.

## Safety devices

Your cylinder is fitted with a:

- Temperature and pressure relief valve (TPR) that ensures the water remains at a safe temperature and pressure.
- Auto-reset thermostat to maintain water temperature.
- Temperature override cutout for heating element.

Do not operate the system unless all the safety devices are fitted and are in working order. It is also important that you do not tamper or remove any of these devices.

## General information

### Cylinder thermostat setting

To meet the New Zealand Building Code requirement<sup>1</sup> to disinfect water for legionella bacteria<sup>2</sup>, the cylinder thermostat has been set to 60 °C.

### Turning the cylinder on/off

If you plan to be away for a few nights we suggest you leave the system switched on. If it is necessary to switch it off, when switching back on, remember that the cylinder will take time to heat back up again.

### Draining /filling the system

This normally occurs during installation or servicing and must be carried out by an authorised person.

### Installation by a licensed tradesperson

Only a licensed tradesperson can install, adjust, maintain, and service this water heater. Any work carried out by a non-licensed tradesperson is illegal and will void any warranty.

<sup>1</sup> Clause G12.3.9, Acceptable Solution G12/AS1 6.14.3

<sup>2</sup> Legionella is a bacterium that can cause Legionnaires' disease—a severe form of pneumonia

# Maintenance and servicing

Hot water systems, like cars, require regular maintenance and servicing. To ensure longevity of your cylinder we recommend the following.

Period	What needs to be done
Every six months	TPR (temperature & pressure relief) valve—operate the easing gear
Year five	Inspection and service of the entire hot water system, including the element*
Every 24 months after year five	Inspection and service of the entire hot water system, including the element*

\* In hard water areas the element(s) must be periodically descaled. To do this the unit must be drained and the element(s) removed.

## TPR valve

Depending on the type of cylinder, this valve is located near the top, or on top of the cylinder and is essential for safe operation. The TPR valve works by automatically venting hot water if the temperature or pressure of the water in the cylinder gets too high.

Every six months operate the easing gear to remove lime deposits and to check that it is not blocked. As this will discharge hot water, ensure no one is near the drain line.

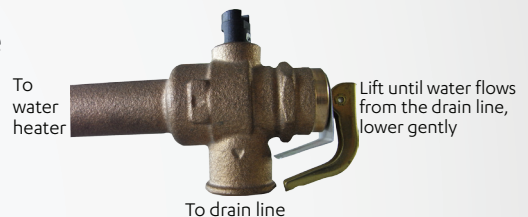

Failure to operate the relief valve easing gear at least once every six months may result in the water heater exploding.

Continuous leakage of water from the valve may indicate a problem. It is important that you raise and lower the easing gear gently. During the operation, if the valve does not discharge water when the easing gear is lifted, or does not seal again when closed, arrange for an authorised person to come and inspect the system immediately.

During servicing of your cylinder the TPR valve needs to be checked and/or replaced. This needs to be done by an authorised person at intervals not exceeding five years, or more frequently in areas where the water is classified as hard.



A TPR valve must not be replaced with one that has a higher temperature or pressure rating than that specified for the cylinder.

## Maintenance & servicing

Rinnai has a maintenance, service, and spare parts network with personnel who are fully trained and equipped to give the best advice on your Rinnai product.

Regular maintenance and servicing is not covered by the Rinnai warranty. For help locating a service person in your area call 0800 RINNAI (0800 746 624).

# Installation

Installation, servicing and repair shall be carried out only by authorised personnel.

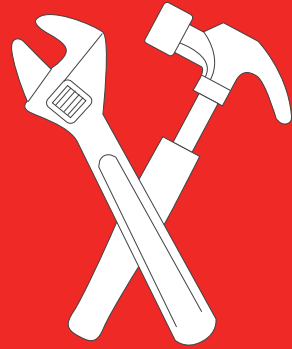

# Specification summary

## Suitability

- Indoor installations
- Main and low pressure systems
- Residential and light commercial water heating systems

**Thermosiphon single coil:** Suitable for connection to a wetback fire or open loop solar system.

**Thermosiphon twin coil:** Suitable for connection to a wetback fire and closed loop solar system.

**Non-thermosiphon single coil:** Suitable for connection to a closed loop solar system.

Not suitable as a pool or spa heater, or for underfloor heating.

The system should be located and arranged so as to achieve the closest proximity to water draw off points.

## Construction

Inner cylinder	Duplex SS
Outer casing	Galvanised steel

## Connections

Hot	¾" (20 mm)
Cold	¾" (20 mm)
TPR	¾" (20 mm) thermosiphon ½" (15 mm) non-thermosiphon

## Coil

	<ul style="list-style-type: none"><li>• Wetback thermosiphon coil 1" 25 mm diam.</li><li>• Auxiliary coil (solar coil) ¾" 20 mm diam.</li></ul>
Length	11 m (0.86 m <sup>2</sup> )
kW rating	Nominal 22 kW

## Operating pressures

Maximum working pressure = 850 kPa

## Element

Incoloy 825 alloy curved sheath element positioned at the bottom of the tank. Incoloy 825 alloy straight sheath element for mid and upper elements.

## Thermostat

Robert Shaw 30 A contact auto-reset thermostat (red dial), part number 20079.

The thermostat setting is between 50-70 °C. Maximum thermostat setting (in order to maintain the warranty) is 70 °C.

## Weights: empty full

	empty	full
Thermosiphon single coil		
• 250 L:	49 kg	299 kg
• 300 L:	56 kg	356 kg

## Thermosiphon twin coil

• 250 L:	55 kg	305 kg
• 300 L:	62 kg	362 kg

## Non-thermosiphon single coil

• 190 L:	42 kg	232 kg
• 250 L:	48 kg	298 kg
• 300 L:	56 kg	356 kg

## Pressure limiting (reducing) valve

This water heater MUST be installed with a 500 kPa or less pressure limiting valve and appropriate cold water expansion valve.

## TPR valve

A temperature and pressure relief valve is supplied with the water heater and MUST be fitted. The TPR valve thread should be sealed with teflon tape, do not use paste and hemp. Use the spanner flats on the valve body to tighten, DO NOT use a wrench on the valve body.

The TPR valve must be fitted with a drain pipe to direct any water discharged to a visible point outside the property. The drain pipe must have a continuous fall and be at least the same size as the TPR valve outlet. Where the drain pipe exceeds three metres in length it is recommended an air break be provided within 300 mm of the TPR valve outlet. Where an air break is used it is recommended that the pipe size after the air break be increased to one size larger than the TPR valve. It must also be protected from freezing conditions.

# Dimensions: Single coil thermosiphon

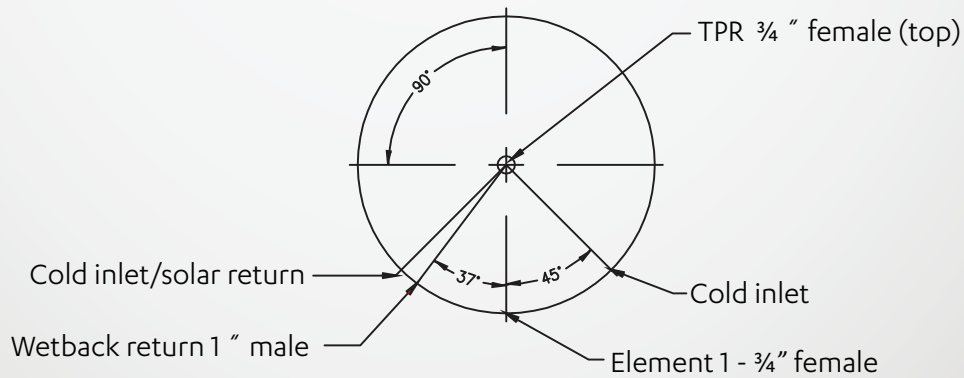
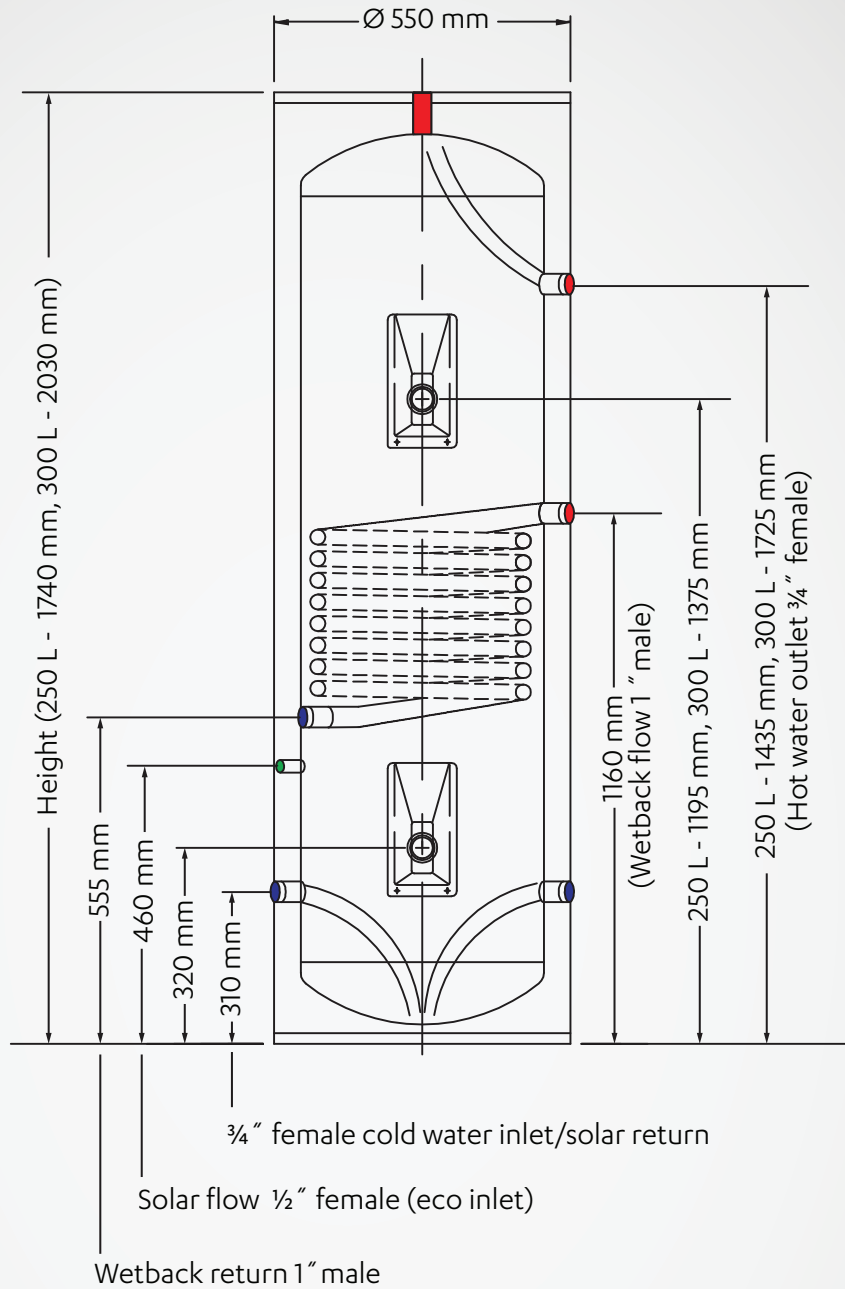

# Dimensions: Twin coil thermosiphon

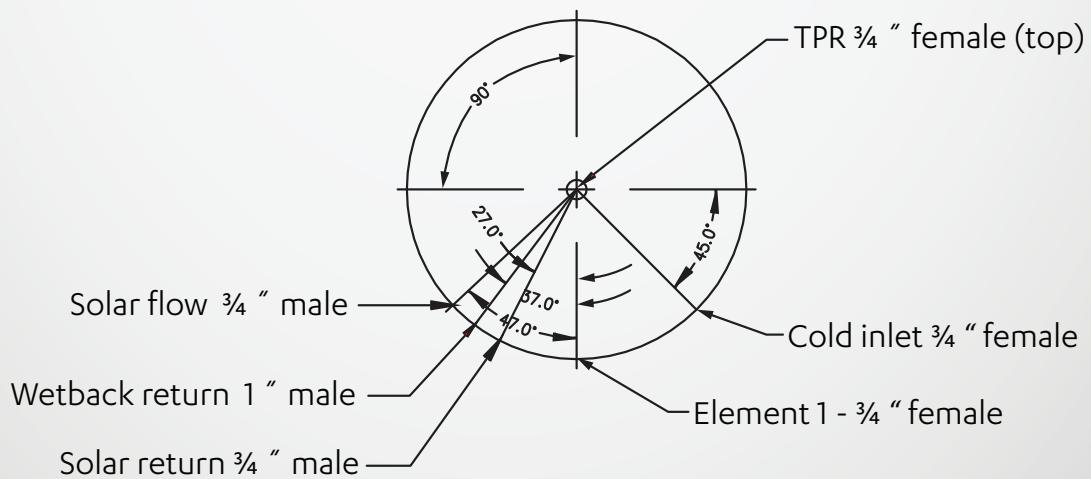
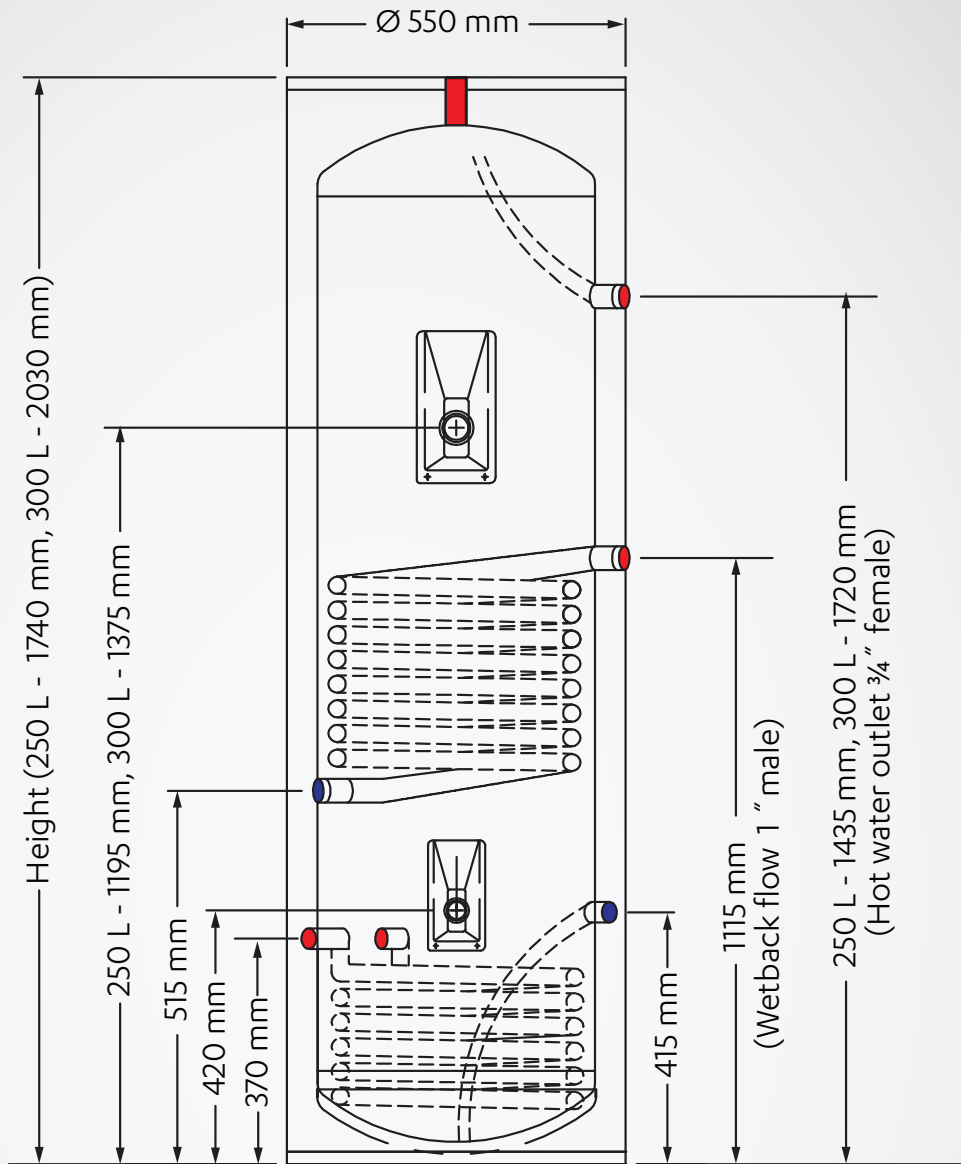

# Dimensions: Single coil non-thermosiphon

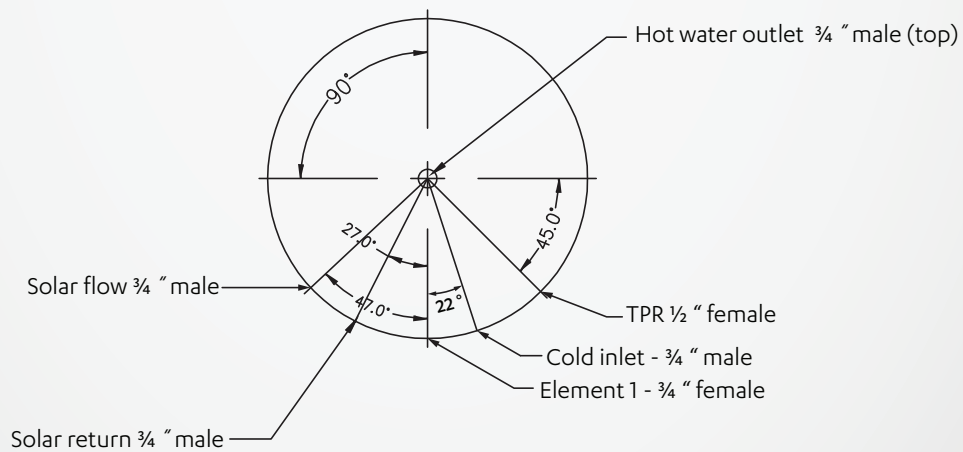
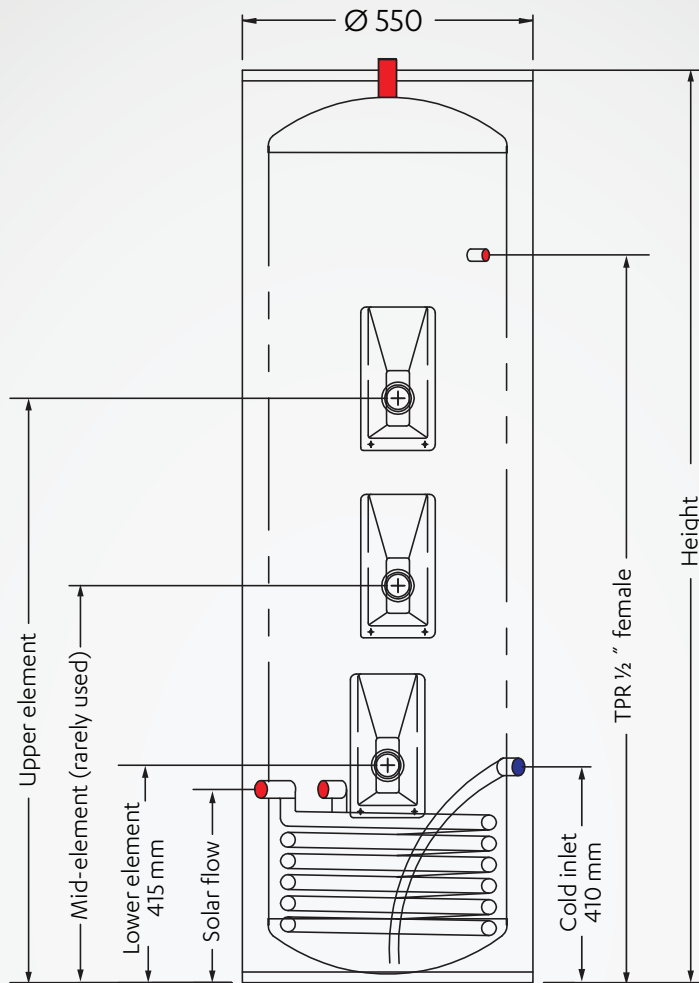

	<b>Solar flow</b>	<b>Mid-element</b>	<b>Upper element</b>	<b>TPR</b>	<b>Height</b>
190 L	365 mm	745 mm	955 mm	1080 mm	1380 mm
250 L	375 mm	780 mm	1075 mm	1380 mm	1730 mm
300 L	375 mm	935 mm	1410 mm	1700 mm	2045 mm

# Plumbing setup

Cylinders should be installed in accordance with G12/AS1. For servicing and maintenance, please allow sufficient room for access to element covers and valves.

## General guidelines

There are multiple setup options for our coiled cylinders depending on the supplementary heating source the cylinder is connected to. For the purpose of this guide only the most common connection diagrams have been included.

### Base requirements

Tanks should be installed on a flat level base of sufficient strength to support the weight of the water heater when full.

The water heater must also be suitably restrained against seismic activity, 'G12/AS1 Figure 14' details an acceptable method of restraint.

### Drip tray/catch pan (MUST be fitted)

The Rinnai warranty does not cover any consequential loss from leaks to the cylinder, so it's important a suitably drained drip tray/catch pan is fitted as per AS/NZS 3500.4:2015 5.4.

### Pipe work

It is the installer's responsibility to adequately size the distribution pipe work in a property to ensure sufficient performance from all outlet fittings. Water pipe sizing should be performed in accordance with AS/NZS 3500.4 and/or G12 AS1. Pipe sizing and valve selection must be performed to allow for the water supply pressure.

A drain off tap or line must be fitted to the inlet of the water heater.

All hot water pipe work should be insulated with polythene foam or equivalent insulation to optimise performance and energy efficiency, and to reduce the risk of coming into direct contact with hot pipes.

To prevent damage to the water heater when attaching pipe clips or saddles to the jacket, it is recommended that self drilling screws with a maximum length of 12 mm are used. If drilling is required take extreme care not to penetrate the inner cylinder.

# Single coil thermosiphon cylinder for open loop solar and wetback

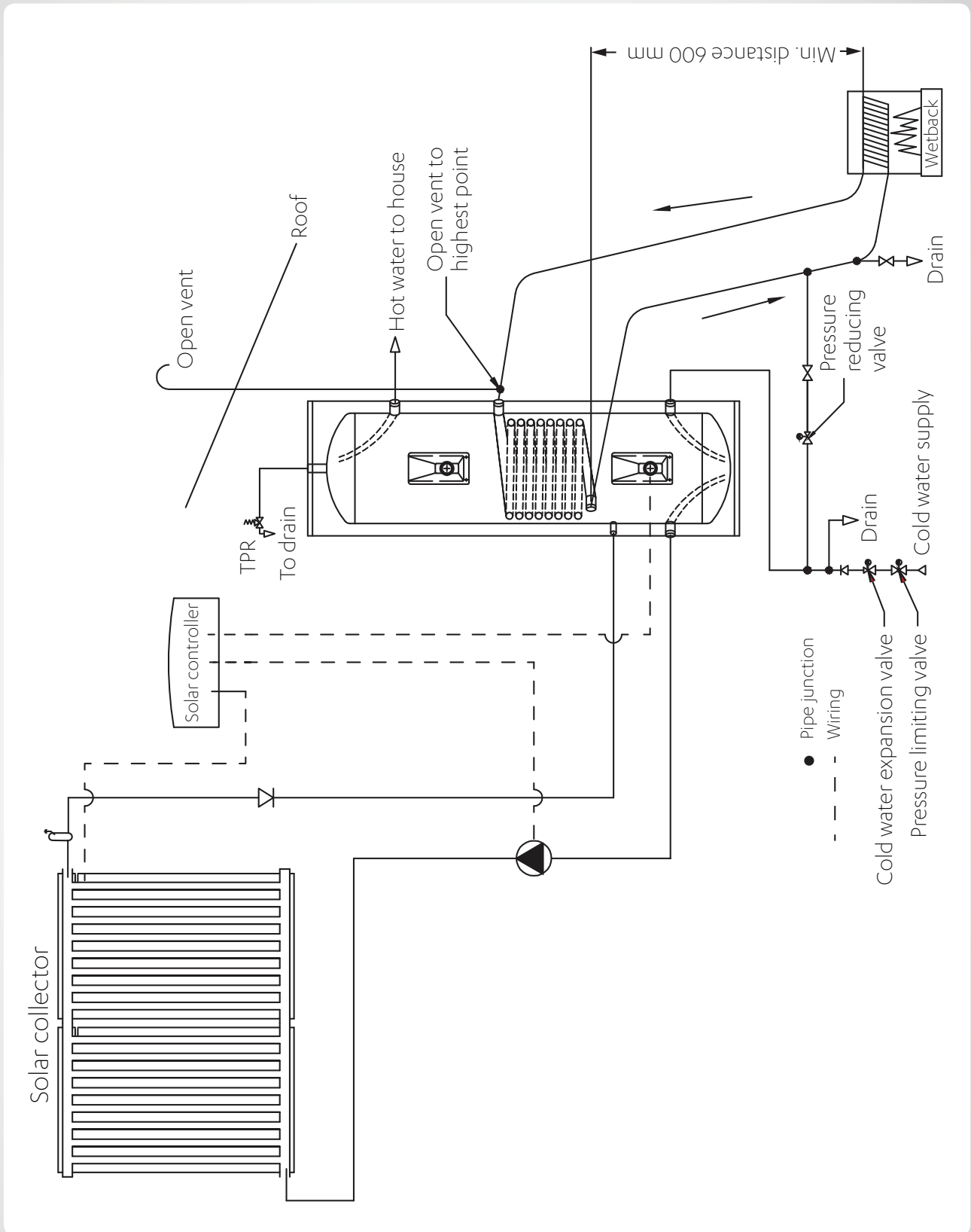

# Twin coil thermosiphon cylinder for closed loop solar and wetback

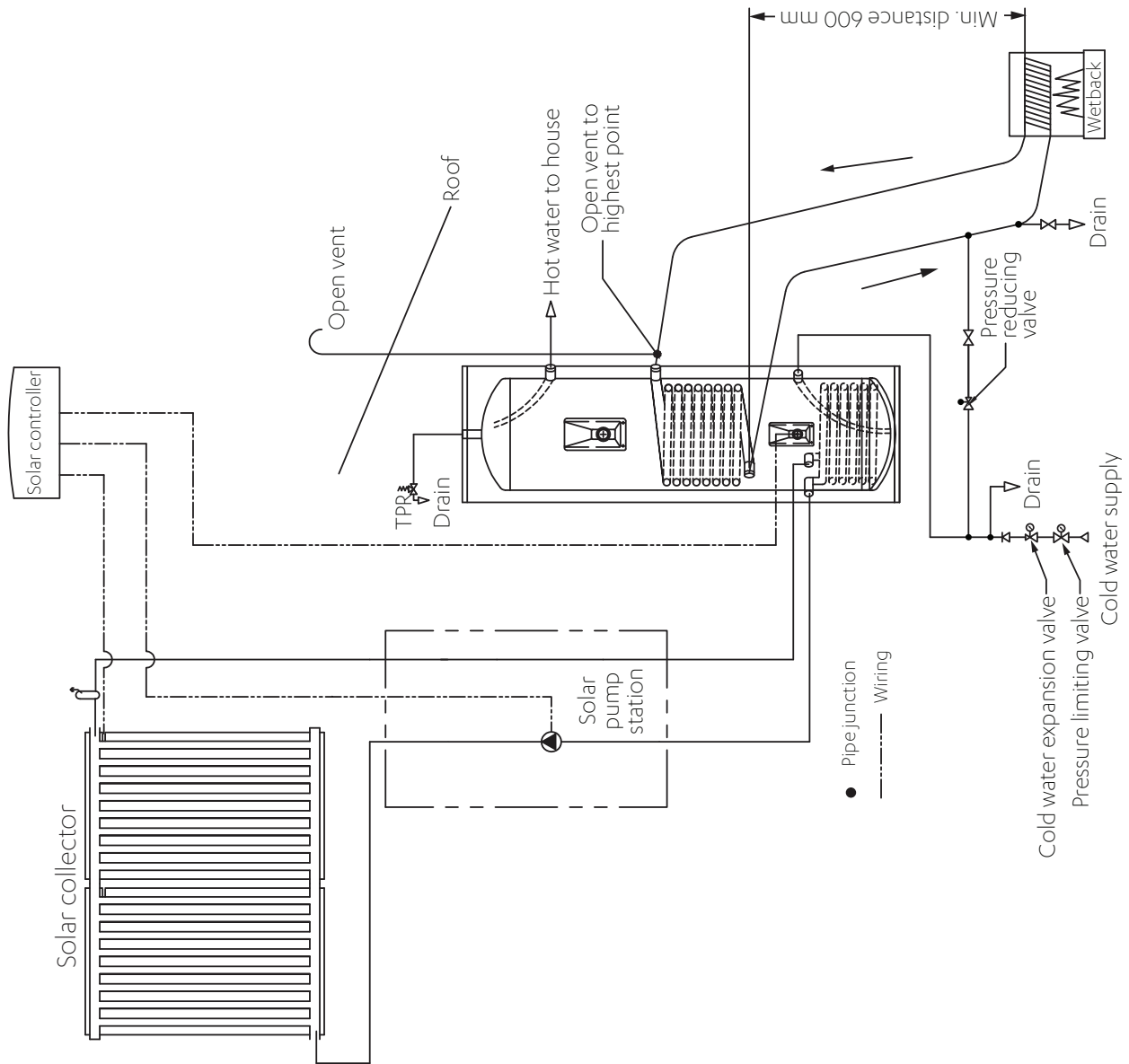

# Single coil non-thermosiphon cylinder for closed loop solar

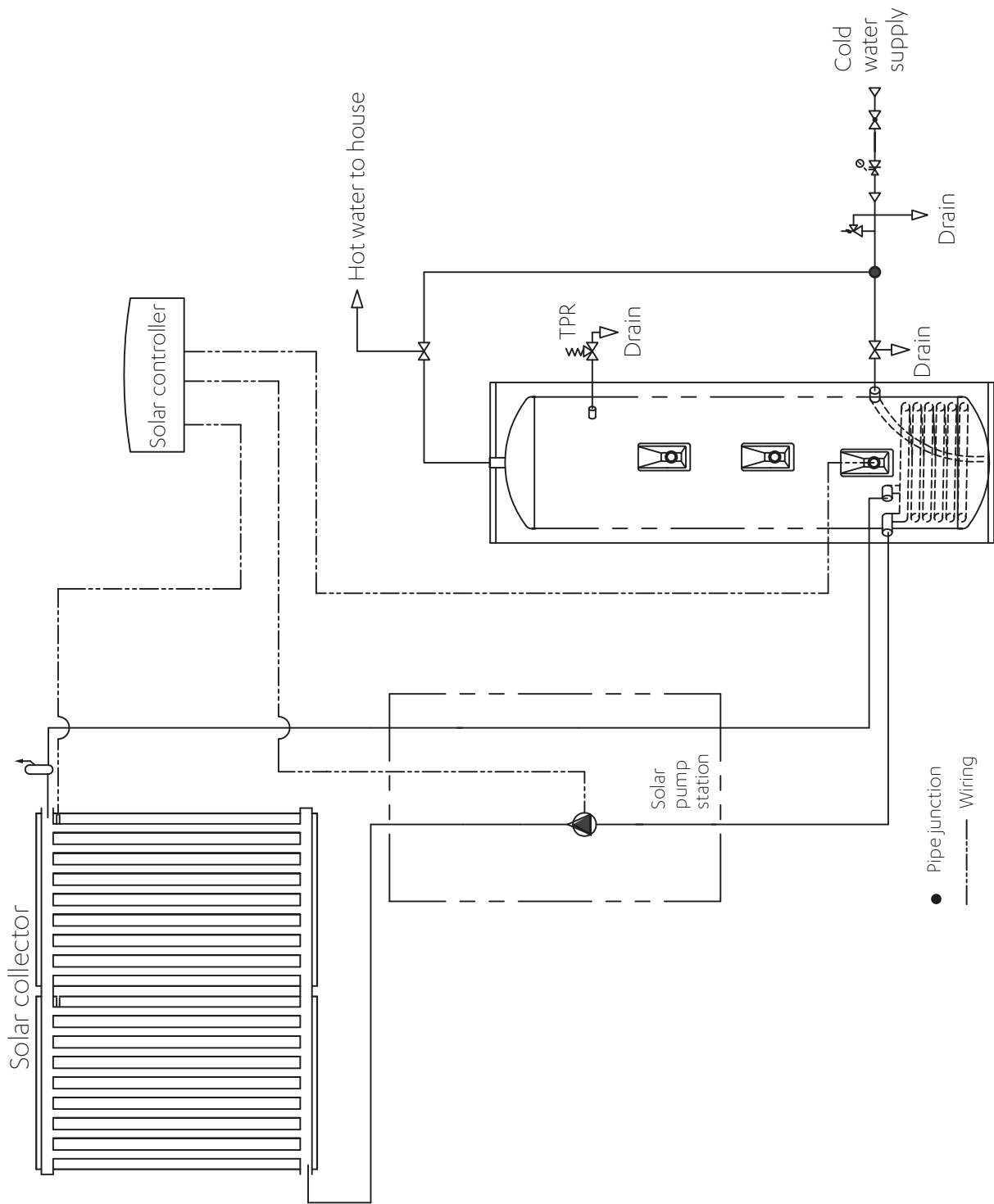

# Storage and delivery temperatures

## Storage temperature

To meet the New Zealand Building Code requirement<sup>1</sup> to disinfect water for legionella bacteria, the cylinder thermostat has been set to 60 °C.

Thermostat settings must only be adjusted by an electrician or other suitably qualified tradesperson. The access cover to the element and thermostat must only be removed by an electrician or other suitably qualified tradesperson.

## Sanitary fixtures delivery temperature

Water temperatures over 55 °C can cause severe scalds. Local regulations must be considered regarding temperature limitations of hot water supplied to areas used primarily for personal hygiene. The temperature is limited to 45 °C for early childhood centres, schools, nursing homes or similar facilities and 55 °C for all other buildings. To comply with these requirements, a temperature limiting device, such as a tempering or thermostatic mixing valve will be required on all installations.

<sup>1</sup> Clause G12.3.9, Acceptable Solution G12/AS1 6.14.3

# Wetback heat exchanger power input table

It is important the kW rating of the wetback heat exchanger is suitable for the capacity of the cylinder otherwise the heat recovery can be too fast and energy will be wasted through the open vent. The below table identifies the maximum kW rating for each cylinder size. For example, a 3 kWh wetback heat exchanger is not recommended for a 190 L cylinder.

Wetback heat exchanger power input	Wetback circuit efficiency	Wetback volume recovery rate		
		190 L	250 L	300 L
1.5 kWh	0.7 %	10.7 hrs	13.3 hrs	17.0 hrs
2.0 kWh	0.7 %	8.1 hrs	9.9 hrs	12.7 hrs
2.5 kWh	0.7 %	6.4 hrs	8.0 hrs	10.2 hrs
3.0 kWh	0.7 %	5.4 hrs	6.6 hrs	8.5 hrs
3.7 kWh	0.7 %	4.4 hrs	5.4 hrs	6.9 hrs
5.0 kWh	0.7 %	3.2 hrs	4.0 hrs	5.1 hrs

Recommended wetback heat exchanger power inputs based on a minimum recovery rate of 6 hours

Not recommended for wetback heat exchanger power inputs—heat recovery rate will be too fast

1.5-3.7 kWh are the most common wetback heat exchanger power outputs in NZ

# Water quality

HJ Cooper by Rinnai water heaters are manufactured to suit most NZ council water supplies. However some water supplies can have a detrimental effect on the water heater, its operation, and life expectancy.



## Pitting corrosion

The HJ Cooper by Rinnai stainless steel tanks are made from LDX 2101 grade duplex stainless steel. This material has very good resistance to pitting corrosion with a Pitting Resistance Equivalent Number (PREN) of 28. This is a commonly used engineering indicator of corrosion resistance in stainless steel materials. The higher the PREN number the greater the resistance. In comparison 304 grade stainless, which is commonly used in domestic cookware and kitchen sinks, has a PREN number of 19. This means that HJ Cooper by Rinnai stainless steel tanks are highly resistant to pitting corrosion, but not completely immune from it.

Pitting corrosion may occur in the form of deposit attack if the water supply has a high percentage of dissolved solids present. It is advised in areas with a high concentration of dissolved solids in the water supply that consultation with water quality and filtration experts be undertaken.

Duplex stainless steel also has superior strength and chloride stress corrosion cracking resistance when compared to the 3000 series of stainless steel.

## Hard water

Hard water (containing calcium carbonate) can cause scaling on hot surfaces. We recommend a water temperature of no more than 65 °C to minimise scale build-up. Scale reducing or water softening devices should be considered in hard water areas. The unit is not guaranteed against damage due to scaling.

Water quality outside the limits (as set down below) will void this warranty. Water quality tests must be carried out at the customer's own cost, but Rinnai will reimburse any reasonable test costs where water quality is within the limits tabled.

## Water Quality and Impurity Limits

<b>TDS (Total Dissolved Solids)</b>	<b>Total Hardness CaCO<sub>3</sub></b>	<b>Dissolved (free) CO<sub>3</sub></b>	<b>pH</b>	<b>Langelier Index</b>
Up to 600 mg/L or ppm	Up to 200 mg/L or ppm	Up to 25 mg/L or ppm	6.5-8.5	Between -1.0-0.8

Most metropolitan water supplies fall within these limits. If you are unsure about water quality, please contact Rinnai and we will provide you with the details of an authorised agency able to test your water for compliance to Rinnai standards. If sludge or foreign matter is present in the water supply, a suitable filter should be incorporated in the water supply.

Some examples of water quality issues where water may need to be treated:

- Hard water (areas including Wanganui)
- Aggressive water (areas including Christchurch)
- Both hard and aggressive water (some bore water)

# Electrical supply and connections

The electrical connection must be carried out by a qualified person in accordance with NZ Electrical Regulations. The water heater must have the heating element connected to an independent, fused, AC 230 V 50 Hz power supply with an isolating switch installed at the switch board. Disconnect all power prior to installation, commissioning, maintenance or service.

- The water heater must be filled with water prior to connection to the power supply
- Household wiring to the heater must be capable of withstanding the appliance load
- Fixed wiring must be protected from contact with the internal hot surface of the water heater

Electrical access is via a hole in the element cover for mounting with an approved electrical conduit gland. For entry to the element cover remove the two fixing screws.

Connect all LIVE, NEUTRAL and EARTH wires in accordance with the wiring diagram. Inspect and ensure all wiring links are secure prior to fixing the access cover and turning the power on.

The appliance is intended to be connected to cables of fixed wiring which has a cross-sectional area of 1.5 mm<sup>2</sup> - 2.5 mm<sup>2</sup>.

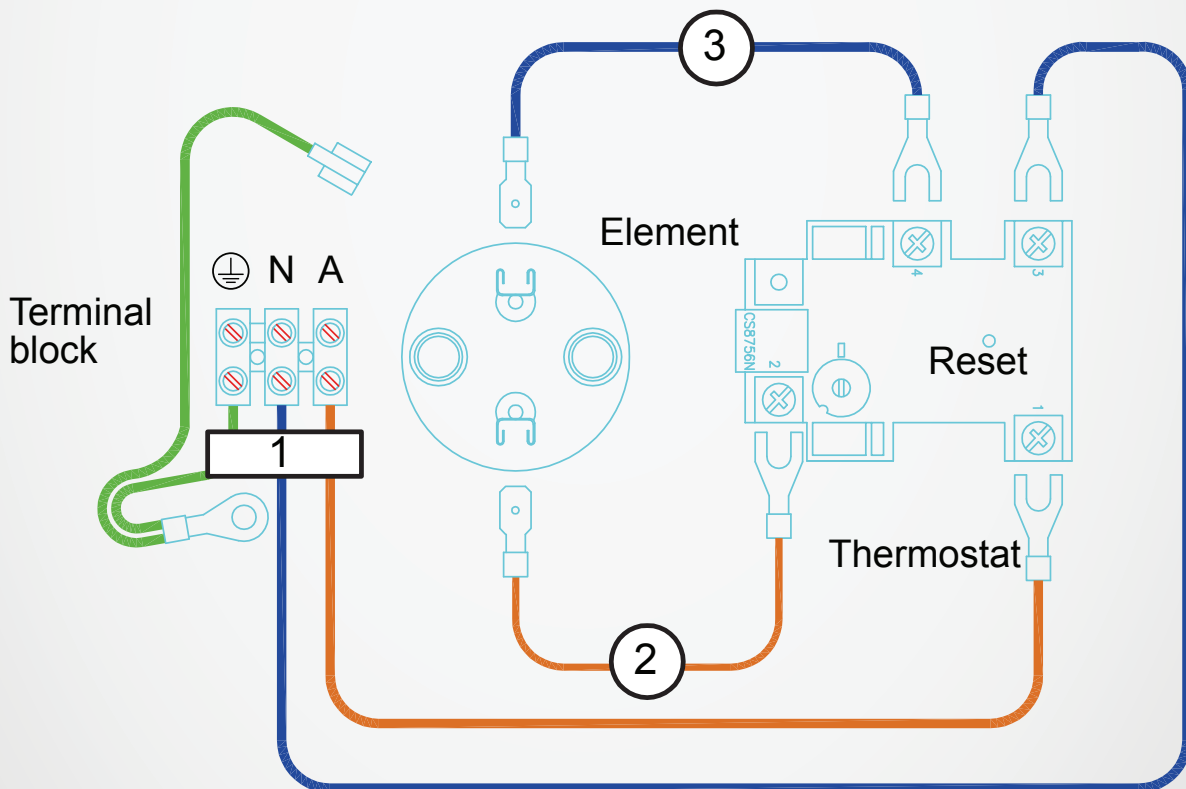

Wire No.	Description	Colour	Code
1	Wiring main loom R/Shaw assy.	Green/brown/blue	20197
2	Wire link brown R/Shaw assy.	Brown	20198
3	Wire link blue R/Shaw assy.	Blue	20199

## Valves and fittings

Valves with pressure ratings other than those listed in this manual must not be used.

### **Fittings supplied with the cylinder**

TPR valve, brass plugs, to plug unused connections, a key spanner, and the owner and installer guide are packaged in a plastic bag inside the element cover.

## Commissioning

Commissioning and draining activities must be carried out by an authorised person.

# Limited Warranty

## Rinnai warranty summary table

This warranty applies to HJ Cooper by Rinnai Coiled Mains Pressure Stainless Steel cylinders only.

All terms of the warranty, subject to the conditions below, are effective from the date of installation. Proof of installation date will be required. Where the date of installation is not known or cannot be proven the warranty will commence one month after the date of manufacture—refer to the data label on the cylinder.

### Single residential application warranty

A residential application is defined as an installation where the water heater, with the thermostat set below 70 °C, delivers hot water to a single family residential dwelling, not used for commercial purposes<sup>1</sup>.

Component	Warranty period	Warranty
All components	Up to 1 year	Replace or repair free of charge the cylinder and/or part if it fails due to faulty manufacture.
Inner cylinder	Years 2-5 inclusive	Replace or repair free of charge* the inner cylinder if it fails due to faulty manufacture.
Inner cylinder	Years 6-10 inclusive	Replace or repair free of charge* the inner cylinder if it fails due to faulty manufacture. The cost of removal of the cylinder, re-installation, and labour costs are the responsibility of the owner.

### Commercial application warranty

Component	Warranty period	Warranty
All components	Up to 1 year	Replace or repair free of charge the cylinder and/or part if it fails due to faulty manufacture.
Inner cylinder	Years 2-3 inclusive	Replace or repair free of charge* the inner cylinder if it fails due to faulty manufacture. The cost of removal of the cylinder, re-installation, and labour costs are the responsibility of the owner.

For commercial applications it is recommended the cylinder is sized according to written guidelines from Rinnai.

<sup>1</sup> Examples where a residential dwelling is used for commercial purposes; hair salon, catering kitchen, communal care facility etc. These installations would be considered commercial applications. An exception would be an accommodation business such as a motel, where the water heater serves the equivalent of a single family dwelling, this would be a residential application.

\* Except for certain travel and transport costs, refer to the 'Warranty terms and conditions' (9).

## General warranty terms

Rinnai reserves the right to make modifications and change specifications and its parts without notice.

For the purposes of the Consumer Guarantees Act 1993, Rinnai only guarantees the availability of repair facilities and spare parts for the express warranty periods recorded in the Rinnai warranty summary table.

If the cylinder is being acquired for personal, domestic or household use, this warranty does not limit any consumer rights or guarantees that may apply under the Consumer Guarantees Act 1993. If the product is being acquired for the purposes of a business, the provisions of the Consumer Guarantees Act 1993 do not apply and no other warranties (either express or implied by law) apart from those stated in this warranty apply.

## Warranty terms and conditions

1. All terms of this warranty are effective from the date of installation. The attending service person reserves the right to verify this date.
2. All Rinnai cylinders must be installed, commissioned, serviced, repaired and removed in accordance with the manufacturer's installation instructions, local regulations, and municipal building codes by persons authorised to do so.
3. All Rinnai cylinders must be operated and maintained in accordance with manufacturer's instructions.
4. The warranty applies only to the components supplied by Rinnai. It does not apply to components supplied by others, such as, but not limited to these, isolating valves, electrical switches, pipe work, electrical cables, and fuses.
5. Where the cylinder has not been sited in accordance with the installation instructions or installed such that normal service access is difficult, a service charge will apply. If at the discretion of the attending service person the installation is deemed illegal or access is dangerous, service will be refused. Any work required to gain reasonable access to the cylinder will be chargeable by the attending service person (for example, removal of cupboards, doors, walls, or the use of special equipment to move components, but not limited to these).
6. The cylinder warranty is for the period indicated in the summary table. Where the inner cylinder and/or part is replaced under warranty, the replacement cylinder and/or part will carry a new warranty.
7. Rinnai reserve the right to transfer functional components from defective water heaters if they are suitable.
8. Rinnai reserve the right to have the installed product returned to the factory for inspection.
9. Where the cylinder is installed outside the metropolitan area or further than 40 km from a Rinnai authorised service centre, travel costs shall be the owner's responsibility.
10. Rinnai reserves the right to replace the cylinder for another type if upon inspection it is deemed another cylinder of a different construction is more suitable.

## Warranty exclusions

The following exclusions may cause the warranty to become void and will result in a service charge and costs of parts (if required).

1. Accidental damage and acts of God.
2. Failure due to abuse or misuse, improper maintenance or improper storage.
3. Failure due to incorrect or unauthorised installations.
4. Failure or damage caused by alterations, service or repair work carried out by persons other than those authorised by Rinnai.
5. Where the cylinder has failed directly or indirectly as a result of poor water quality outside the limits specified.

<b>TDS (Total Dissolved Solids)</b>	<b>Total Hardness CaCO<sub>3</sub></b>	<b>Dissolved (free) CO<sub>3</sub></b>	<b>pH</b>	<b>Langelier Index</b>
Up to 600 mg/L or ppm	Up to 200 mg/L or ppm	Up to 25 mg/L or ppm	6.5-8.5	Between -1.0-0.8

6. Where it is found that there is no fault with the cylinder and the issue is related to the installation or is due to power failure.
7. Subject to any statutory provisions to the contrary, Rinnai does not accept:
  - a. liability for consequential damage or any incidental expenses resulting from any breach of the warranty,
  - b. claims for damage to building or any other consequential loss either directly or indirectly due to leaks or any other faults.

# Warranty examples in the real-world

We understand warranty information can be confusing. To help clarify what this means in the real-world we have developed some single residential application scenarios to clarify what would fall within warranty and what wouldn't.

Scenario	Age of part/ cylinder	Within warranty	
Faulty thermostat	10 months	Yes	All costs covered by Rinnai.
Faulty element	3 years	No	All costs covered by the owner.
Cylinder leaks as a result of a faulty inner cylinder and causes damage to carpets and flooring	11 months	Yes/No	Cost of cylinder replacement covered by Rinnai. Consequential loss, damage to carpets and flooring, is not <sup>1</sup> .
Inner cylinder fails	7 years	Yes	Cost of cylinder replacement covered by Rinnai. The cost of removal of the cylinder, re-installation, and labour costs are the responsibility of the owner.
Outer cylinder showing signs of corrosion	3 years	No	Only the inner cylinder is covered by warranty

## <sup>1</sup> Consequential losses

All cylinders are required to be installed with a drip tray, this is a mandatory requirement of the installation. If damage is caused by a leaking cylinder that has not been installed with a drip tray the owner can seek compensation through the installer or consider claiming on insurance.

# Product registration

You can register your product online at [rinnai.co.nz/register](http://rinnai.co.nz/register).

## Proof of purchase

RECORD YOUR DETAILS  
OF PURCHASE BELOW:

ATTACH YOUR PROOF OF  
PURCHASE HERE:



Retailer: \_\_\_\_\_

Retailer address: \_\_\_\_\_

Date of purchase: \_\_\_\_\_

Product details: \_\_\_\_\_

\_\_\_\_\_

\_\_\_\_\_

**Please keep these details in a safe place for future reference.**

## Installer details

Company name: \_\_\_\_\_

Installer name: \_\_\_\_\_

Address: \_\_\_\_\_

\_\_\_\_\_

Phone: \_\_\_\_\_ Mobile: \_\_\_\_\_

Signed: \_\_\_\_\_ Date: \_\_\_\_\_



Experience our innovation

**Rinnai.co.nz** | **0800 746 624**

<http://www.youtube.com/rinnainz>

<http://www.facebook.com/rinnainz>