

RINNAI

HD250i Direct Flueing with Wall Terminal Flueing Installation Instructions

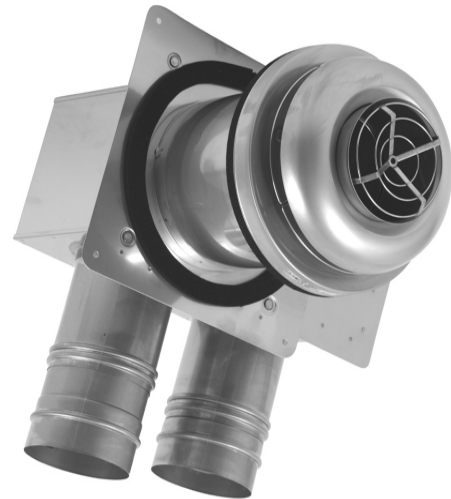

This flue shall be installed in accordance with:

- Manufacturer's Installation Instructions
- Local Gas Fitting Regulations
- Municipal Building Codes
- NZS:5261 Installation Code
- Any other local relevant statutory regulation

This appliance and flue system must be installed, serviced and removed by an Authorised person.

HD250i Direct Flueing - Summary

Direct Flueing with Wall Terminal

For installations where the Rinnai Infinity HD250i Internal is mounted directly on the inside of an external wall.

The HD250i Direct Flue Kit (FFTL-10-200) can be used to flue through walls **150-250mm thick** (this can not be extended).

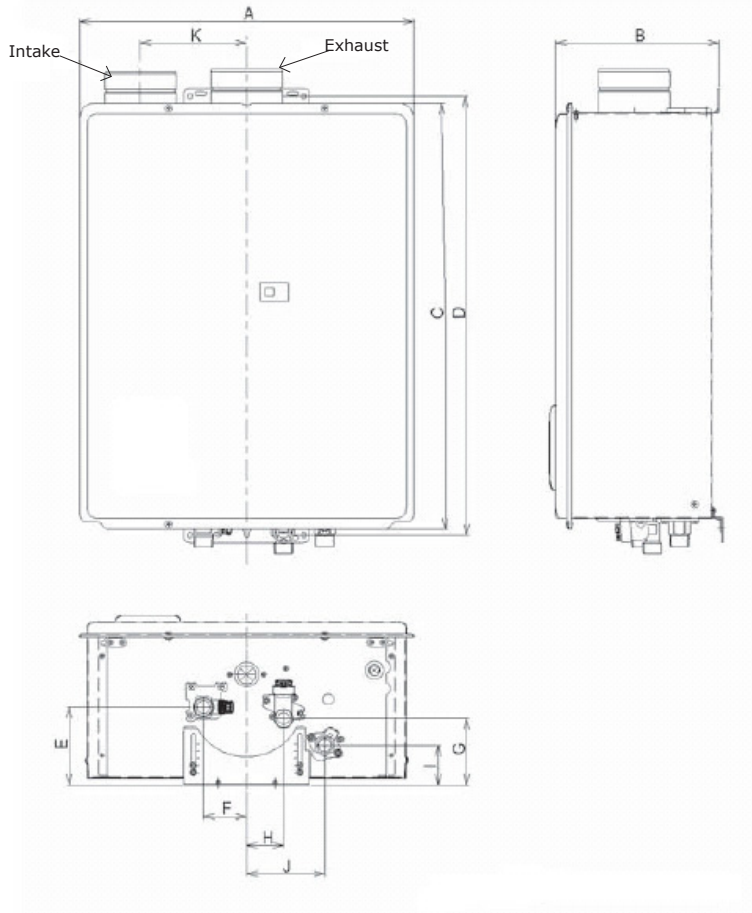

DIM	Description	DIM (mm)
A	Width	470
B	Depth	220
C	Height - Unit	600
D	Height - Including Brackets	620
E	Hot Water Outlet (from wall)	112 ~149
F	Hot Water Outlet (from center)	61
G	Cold Water Outlet (from wall)	94 ~135
H	Cold Water Outlet (from center)	51
I	Gas Connection (from wall)	56 ~96.5
J	Gas Connection (from center)	110
K	Distance between Flue Pipes	150

Positioning - Space Required

Inside

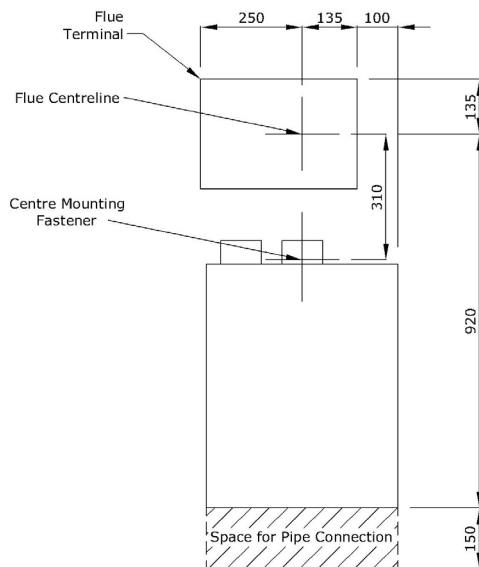

Outside

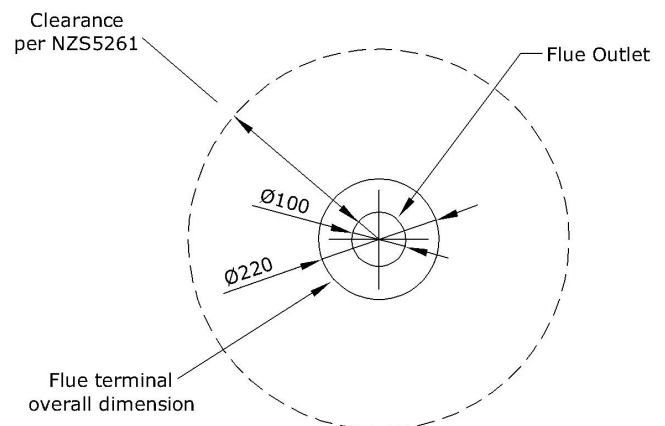

HD250i Direct Flueing - Kit / Important

Direct Flueing - Kit Components

Flue Terminal



Chamber

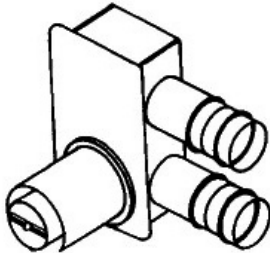

Sleeve

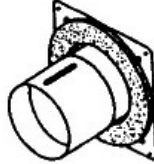

Condensate Proof Cover



Screw Kit (in actual kit, screw components are packaged in a clear plastic roll pack)

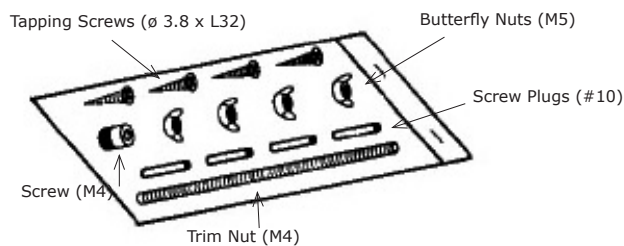

Important Installation Notes

- The components of this flueing system **CAN NOT BE CUT**, use telescopic components to achieve the required length
- Ensure positioning of the flue terminal and flue installation comply with NZS:5261. The flue products can reach temperatures above 200°C.
- Flue must be supported and be independent of the appliance
- Ensure the appliance can be removed without causing movement or displacement of the flue
- Flue components are self-locking
- The O-Rings in all the components are pre-greased, ensure they are not damaged when joining
- When preparing the wall penetration, cover flue spigot to prevent debris from entering the appliance

Before Installation

- Wall hole diameter is \varnothing 175mm or greater and is secure
- That there is a 2° angled fall to the flue terminal
- Length of sleeve tube has been checked, wall thickness can be 150 - 250mm thick
- Distance to surroundings of the flue terminal as per NZS:5261

HD250i Direct Flueing - Installation

Sleeve / Chamber Installation

- Adjust sleeve length to thickness of wall allowing an additional 15mm (this is so it sits inside the flue cowl) and secure sleeve to chamber with screw (B). Ensure you align sleeve and screw with predrilled hole / slot.

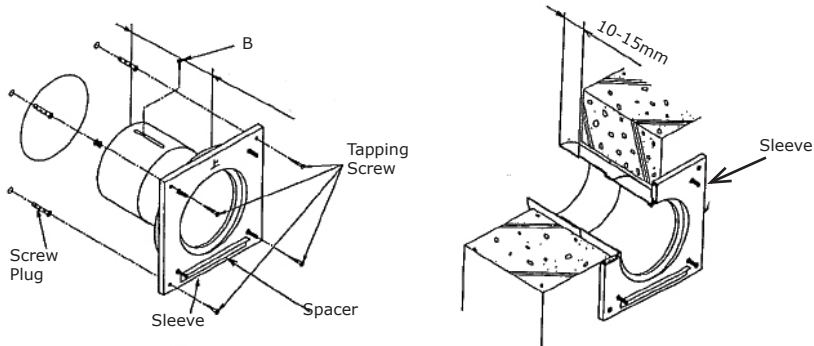

- Insert sleeve / chamber into wall and mark screw position where the sleeve will attach to the wall
- Drill screw position and insert screw plugs
- Fit sleeve plate with four screws ensuring spacer is positioned so there is a 2° angled fall
- Apply plaster filling to gap between sleeve and wall and silicon sealant around the sleeve tube

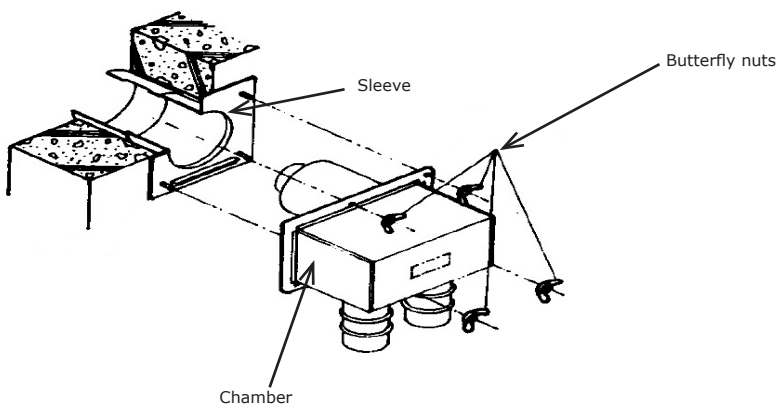
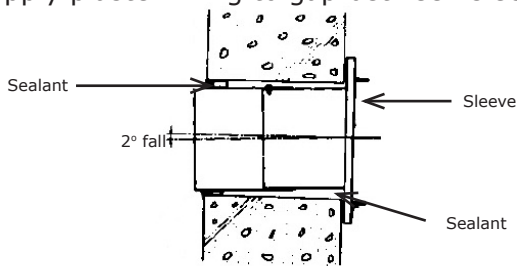

HD250i Direct Flueing - Installation

Flue Terminal Installation

- Insert flue terminal into chamber so as the terminal is angled to fall

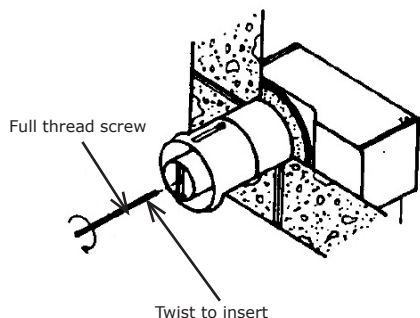

- Fit terminal with condensate proof cover with trim nut and apply silicone sealant around flue terminal

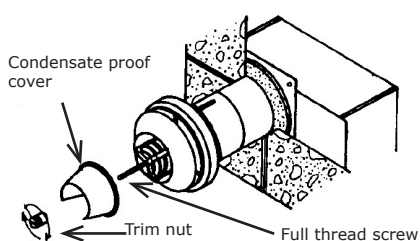

- Within the condensate cover there is a wind buffer plate which can be configured to certain positions if obstructions exist.

Left Obstruction

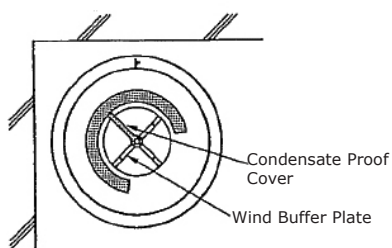

Upper Obstruction

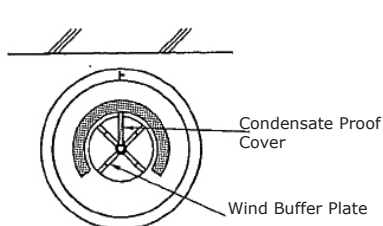

Right Obstruction

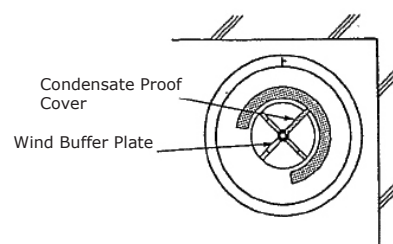

Customer Contacts

For more information about buying, living and servicing of Rinnai gas appliances call 0800 RINNAI (0800 746 624).

Rinnai New Zealand Limited
691 Mt Albert Road
PO Box 24068, Royal Oak, Auckland
Email: info@rinnai.co.nz
www.rinnai.co.nz

All Rinnai appliances meet or exceed the safety standards required by New Zealand gas and electrical regulations.

Rinnai is constantly improving its products and as such specifications are subject to change or variation without notice.

RINNAI

HD250i Direct Flueing with Wall Terminal



PART NUMBER: 15246
Issue: A