

ME275685E20H  
ME340685E20H

RHPN361H

RHPN361A275E20  
RHPN361A340E20

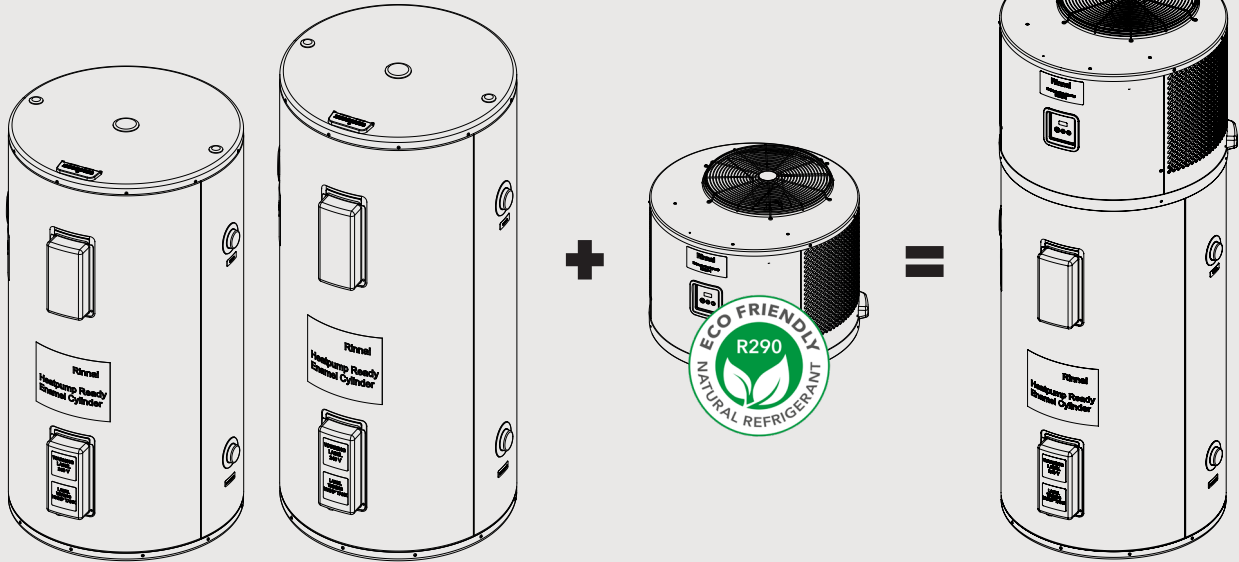

# HydraHeat™ Integrated Hot Water Heat Pump

## Installation guide

**Rinnai**

---

# Important

---

This hot water system shall be installed in accordance with:

- Manufacturer's installation instructions

Current:

- AS/NZS 3000 Electrical Standards
- AS/NZS 3500 Plumbing and Drainage Standards
- AS/NZS 5149 Refrigerating Systems Operation
- New Zealand Building Code Clause G12 Water Supplies

Appliance must be installed, commissioned, serviced, and removed only by licensed tradespeople.

Not suitable as a spa or swimming pool heater.

Not suitable for hydronic systems or for in-series installation in ring main systems.

## **Warning**

Improper installation, adjustment, alteration, service, maintenance, and removal can cause property damage, personal injury or loss of life.

This system is not to be used by persons (including children) with reduced physical, sensory or mental capabilities, or lack of experience and knowledge, unless they have been given supervision or instruction.

For more information about buying, using, and servicing of Rinnai appliances call: 0800 RINNAI (0800 746 624).

Rinnai New Zealand Limited  
105 Pavilion Drive, Mangere, Auckland  
PO Box 53177, Auckland Airport, Auckland 2150

Phone: (09) 257 3800  
Email: [info@rinnai.co.nz](mailto:info@rinnai.co.nz)  
Web: [rinnai.co.nz](http://rinnai.co.nz)  
[youtube.com/rinnainz](https://www.youtube.com/rinnainz)  
[facebook.com/rinnainz](https://www.facebook.com/rinnainz)

---

# Contents

---

Important information.....	4
Before you start .....	5
Specification .....	6
Dimensions (mm) .....	7
Data labels.....	8
Schematic.....	9
Location.....	10
Clearances .....	12
Connections and plumbing arrangement .....	13
Storage and delivery temperatures .....	16
Water quality.....	17
Electrical supply and connections .....	19
Wiring diagram head unit.....	20
Wiring diagram cylinder .....	21
Connecting the head unit and cylinder .....	22
Commissioning .....	25
Error / warning codes .....	27
Manual purging procedure.....	29
Controller interface .....	30
Appendix: Commercial concept sketches.....	34

# Important information

## WARNING

Installation and service to be carried out by a licensed tradesperson.

**DO NOT** operate this system before reading the operation and installation information.

**DO NOT** place articles on or against this appliance.

**DO NOT** store chemicals or flammable materials near this appliance.

**DO NOT** operate with panels or covers removed from this appliance.

**DO NOT** activate heating elements unless full of water.

For safe operation this water heater is fitted with:

- A combination Temperature & Pressure Relief (TPR) Valve.
- One thermostat and one over-temperature control for each heating element.

Operation of the over-temperature cut-out indicates a possibly dangerous situation. It must only be reset by an authorised person after the appliance has been inspected and serviced as required.

**DO NOT** tamper or remove any of the safety devices noted above.

**DO NOT** operate this water heater unless all these devices are fitted and in working order.

## TEMPERATURE AND PRESSURE RELIEF (TPR) VALVE

A TPR valve must be fitted. It must be installed in accordance with these instructions.

## WARNING

The valve and drain pipe must never be sealed or blocked.

**DO NOT** supply heat to any fittings when making connections. Ensure all pipes are clean and free from any foreign matter before making connections. Check water leaks at all joints. Damage caused by leaking joints is not covered by warranty.

**DO NOT** build this appliance in such a way that it can not be easily serviced or replaced. Additional cost incurred by such installations is not covered by warranty.

**MAKE SURE** the cylinder is full of water before energising the system. Failing to do so can cause irreparable damage to the element and sensors.

## Head unit handling

The head unit must only be handled / lifted using the hand holds provided. Two exist on the outside, and the other two can be accessed by removing the front access panel (two screws). NEVER place the head unit on its side.

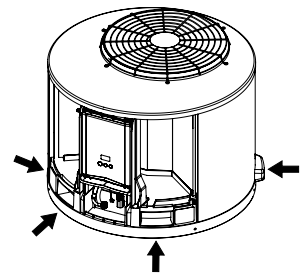

AS/NZS 60335.2.40

## WARNING

Do not use means to accelerate the defrosting process or to clean, other than those recommended by the manufacturer.

The appliance must be installed as specified in this installation guide, without continuously operating ignition sources in the vicinity.

Do not pierce or burn.

Be aware that refrigerants may not contain an odour.

## Electrical supply

Rinnai does not endorse the use of power supplies that supply clipped waveform AC power to the appliance and will not warrant any product connected to such a supply. Similarly if an appliance is supplied with an over-voltage / overcurrent supply, this is also not warrantable.

Voltage and frequency that matches the NZ legislative requirement for 230 V AC mains supply:

- Must be a standard 230 V nominal voltage
- Must be kept within 6% of that voltage, except for momentary fluctuations
- The frequency of electricity supplied must be maintained with 1.5% of 50 Hz, except for momentary fluctuations
- Must conform to a full sinusoidal AC waveform

Regardless of the means of that power generation, normal warranty provisions will apply. This means if your generator or inverter is able to provide power to the HydraHeat with the specification above, then the appliance will function correctly with a low chance of power supply related issues.

## Before you start

Unpack the appliance and components, and remove all transit packaging. Check for damage. DO NOT install any damaged items. Check all components have been supplied, refer below.

Read these instructions to get an overview of the steps required before starting the installation. Failure to follow these instructions could cause a malfunction of the appliance. This could result in serious injury and/or property damage.

### Head unit

Ensure the head unit is delivered the right way up as indicated on the carton. If the unit arrives inverted immediately place the right way up and allow one hour for rebalancing of the oil in the system. If, on inspection, oil has pooled out of the pipes DO NOT install.

### Cylinder components

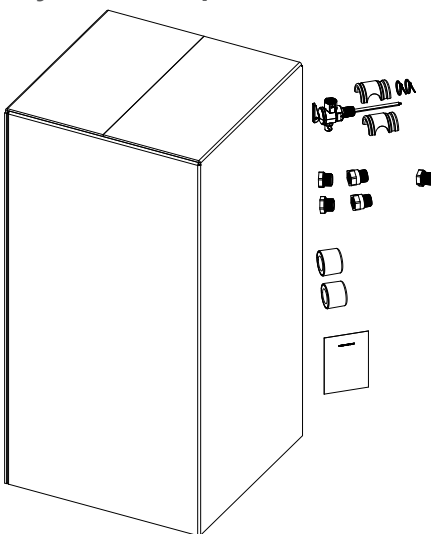

- TPR valve, insulation covers, and cable ties
- TPR brass reducing socket (20-15) x1
- Brass extension socket and plugs (20 mm) x 2, to plug the unused hot and cold connections
- Instructions

### Head unit components

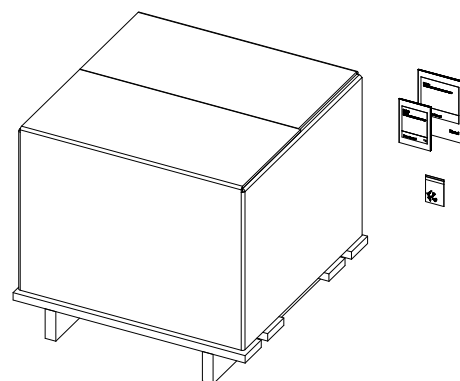

- Instructions
- Fixing screws x 4

# Specification



## Product description

Designed and assembled in New Zealand, the Rinnai HydraHeat Integrated is designed primarily for outdoor installations. It may be possible to install the HydraHeat internally if the proposed location is not an occupied space as defined by AS/NZS 5149, refer p.10 for more information.

The Rinnai HydraHeat Integrated is preset to 'Standard' mode—heating water to a minimum of 60 °C.

The system is provided as two separate components. The storage cylinder, with left or right handed plumbing connections, can be purchased on its own with the purchase and addition of the head unit at a later stage.

## Scope of use

Primarily designed for residential applications. Must be installed in a location complying with clearances stated on p.10 and located as close as practicable to the most frequently used hot water outlets to reduce the delay for hot water delivery.

Not suitable for spa or swimming pool heating, hydronic systems, or for in-series installation in ring main<sup>1</sup> systems. Hard or acidic water will need to be treated to use this product, refer water quality p.17.

<sup>1</sup> If using a ring main with any Rinnai heat pump, use a separate Rinnai electric ring main re-heating cylinder. Refer p.36 for more information.

Operating temperatures	-10 °C to +42 °C
Outlet water temperature	Standard: 60 °C, Eco 55 °C, Eco 50 °C
Storage capacity	275 L and 340 L
Maximum valve pressure settings:	
• TPR (supplied)	• 850 kPa, 99 °C, 10 kW
• Cold water expansion valve	• 700 kPa
• Pressure limiting valve	• 500 kPa
Coefficient of performance (COP)	4.7 (Operating conditions 19 °C ambient, 19 °C water, eco mode 55)
Rated heat pump input/output <sup>1</sup>	802 W / 3725 W
Max. current (heat pump standard mode)	4.6 A
Max. current heat pump (element only)	9.6 A
Max. current (boost mode)	14.2 A
Backup resistance element rating capacity	2 kW
Max. heating capacity	5500 W - boost mode
Min. inlet water pressure	100 kPa
IP rating	IPX4 head unit and tank (protects from splashing water, no matter the direction)
Sound pressure level at 1 m	45 dB(A) <sup>2</sup>
Power supply	230-240 V 50 Hz
Head unit data label position	Positioned on the divider panel between the fan and compressor—to the right of the control panel.
Weight: Head unit	Head unit - 36.4 kg (net weight), 45 kg (packaged weight)
Weights: Cylinder (empty / full)	• 275 L: 77 kg / 352 kg • 340 L: 92 kg / 432 kg
Weights: Assembled system	• 275 L: 114 kg (net) / 400 kg (gross) • 340 L: 128 kg (net) / 477 kg (gross)
Refrigeration type / mass (kg)	R-290 / 150 g (nominal charge)
Refrigeration classification	A3 flammable

<sup>1</sup> In standard and Eco 50/55 modes, the heat pump provides 100% of the heating within the operating temperature range (excluding the weekly Legionella cycle). Outside these limits the electric element will operate.

<sup>2</sup> Sound pressure level measured at 1 m distance from the water heater in a free field. Appliance operated in standard mode (60 °C) at an ambient temperature of 19 °C

# Dimensions (mm)

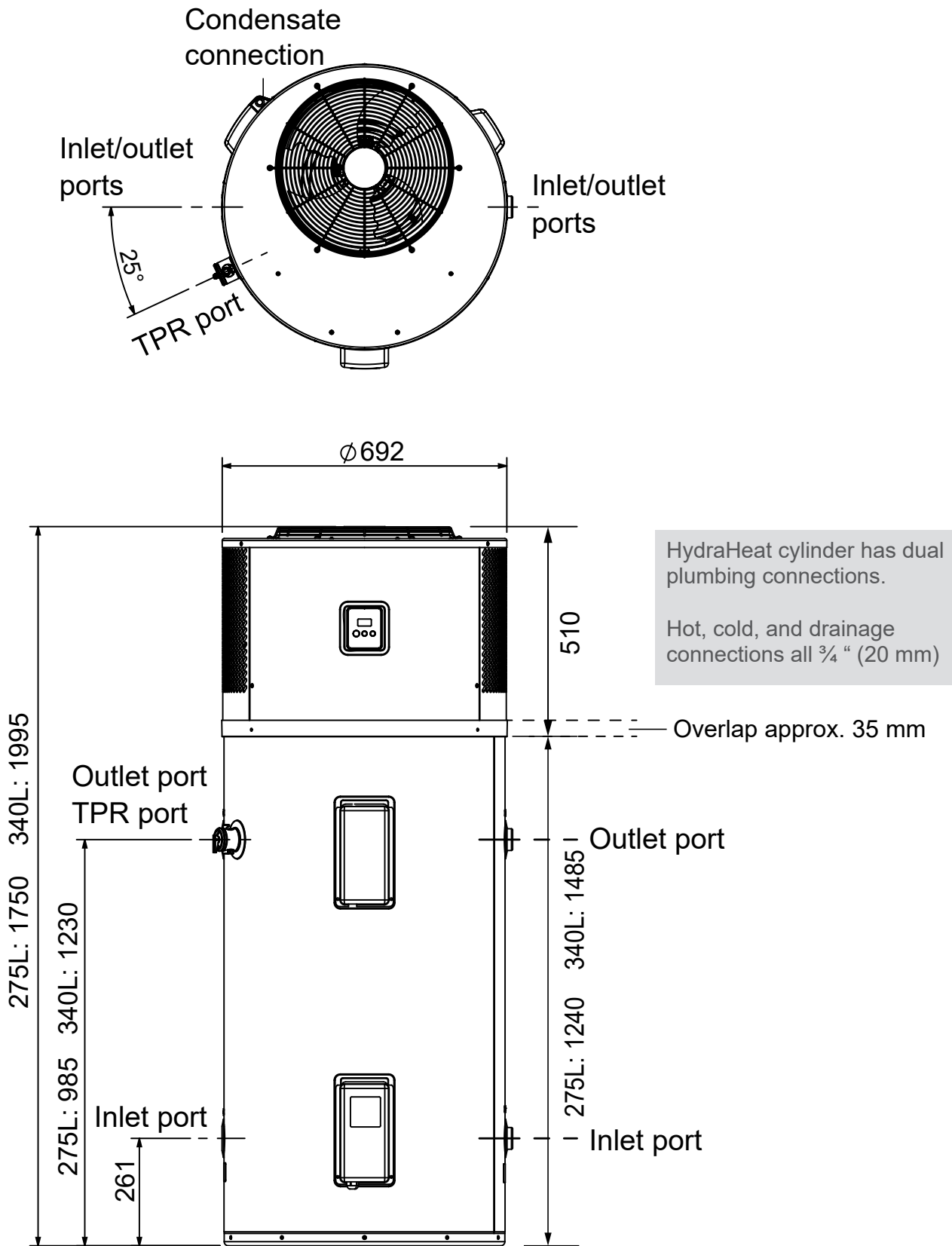

Hot water recovery rate = 89 L/h  
Recovery rate calculated at Eco 55, 19 °C ambient temperature, 36 °C temperature rise.

# Data labels

<b>Rinnai Electric Storage Water Heater 275 L / 340 L</b>		
<b>Model</b>	ME275685E20H	ME340685E20H
<b>Date of manufacture</b>	yyy/mm/dd	yyy/mm/dd
<b>Storage water heater capacity (Litre)</b>	275	340
<b>Dimensions (mm)</b>	Ø685 x 1265	Ø685 x 1520
<b>Heated element rated power input (kW)</b>	2.1-2.3	2.1-2.3
<b>Electrical power supply</b>	230-240 V ~ 50 Hz	230-240 V ~ 50 Hz
<b>Maximum working pressure (kPa)</b>	850	850
<b>TPR valve pressure rating (kPa)</b>	850	850
<b>TPR valve rating (kW)</b>	10	10
<b>Maximum thermostat setting (°C)</b>	75	75
<b>Vitreous enamel class</b>	X	X
<b>Ingress protection rating</b>	IPX4	IPX4
Made in China for, and to the specification of Rinnai NZ Ltd		

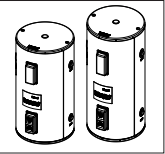

<b>Rinnai Hot Water Heat Pump</b>	
<b>Model</b>	RHPN361H
<b>Refrigerant</b>	R290
<b>Refrigerant operating pressure</b>	2.5 MPa maximum
<b>Water operating pressure</b>	100 kPa minimum 700 kPa maximum
<b>Water inlet temperature</b>	5 °C minimum 30 °C maximum
<b>Water outlet temperature</b>	50 °C minimum 60 °C maximum
<b>Power</b>	230-240 VAC 50 Hz, 16 A
<b>IP rating</b>	IPX4
<b>Manufactured date</b>	xx xx
Manufactured by Rinnai NZ Ltd, Auckland NZ	

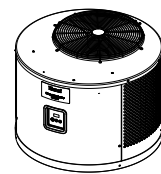

The head unit data label is positioned on the divider panel between the fan and compressor—to the right of the control panel.

# Schematic

- Two piece design, MEPS rated, dual handed outdoor hot water cylinder, corrosion proof plastic heat pump base
- Flexible hose connection tank-top module plus single mains rated connector (reduced connections for the installer)
- All weather OLED (organic light emitting diode) display, capacitive (uses conductive touch of a human finger)

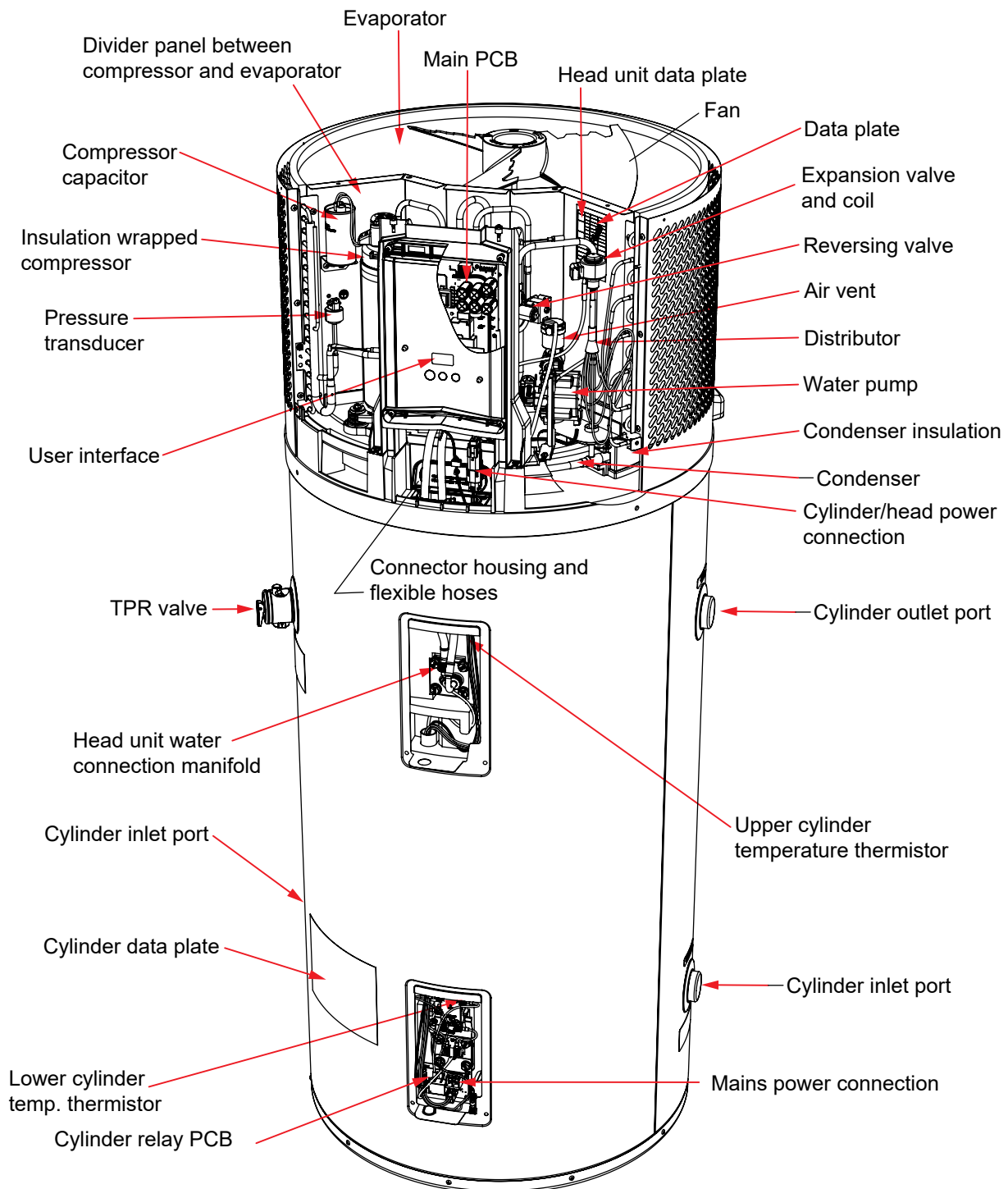

# Location



As the heat pump contains flammable refrigerant, ensure the installation location complies with the requirements of AS/NZS 5149. DO NOT install the unit in a location that may be exposed to combustible gas leaks. If combustible gas accumulates around the unit, it may cause a fire.

The HydraHeat should be placed as close as practicable to the most frequently used hot water outlet point or points to minimise the delay time for hot water delivery. For installations where the distance between the heat pump and the outlets is considerable, a flow and return system can be used to reduce the waiting time for hot water delivery.

The HydraHeat is designed primarily for outdoor installation. It may be possible to install the HydraHeat internally if the proposed location is **not an occupied space** as defined by AS/NZS 5149.1 3.2.6. An extract has been provided below for those that do not have access to this standard.

## 3.2.6

### occupied space

space in a building bounded by walls, floors, and ceilings and which is occupied for a significant period by persons.

Note 1 to entry: Where the spaces around the apparent occupied space are, by construction or design, not airtight with respect to the occupied space, these can be considered as part of the occupied space, e.g. false ceiling voids, crawl ways, ducts, movable partitions, and doors with transfer grilles.

The HydraHeat, by the above definition, would not be suitable for installation into an attached garage.

Examples of an unoccupied space:

- Adequately ventilated plant room
- Adequately ventilated shed



Internally installed units will need adequate ventilation as the appliance has a cooling effect on the installed space, operating noise should also be considered.

### Avoid installing:

- Directly below an opening window, the system discharges a large volume of cold air from the top of the unit.
- In areas where the air inlet and outlets could get blocked / clogged.
- In highly planted areas where falling leaves and other debris could block the air vents or potentially damage the unit.
- In areas with multiple structures, for example fences, concrete walls, retaining walls, screens etc unless these are well ventilated to let the cold air escape.



The HydraHeat can be installed in coastal locations, but not immediately facing salt spray or prevailing winds. It needs some form of shelter otherwise salt will quickly clog the evaporator.

## Noise



Ensure that the installation location complies with local noise regulations regarding neighbouring properties. The location must consider noise impact on living areas. Avoid positioning near bedrooms or neighbours bedrooms. Although the running noise level is low it can be expected that the heat pump will run during the night. The timer function can be used to limit operating hours if noise is a concern.

- Avoid placing the unit less than 3 m from a neighbour's window (windows are less soundproof than walls, and they can be opened), or door other than a garage door or shed.
- Avoid placing the unit near boundary lines.



- DO NOT place any objects on top of the unit, this could cause excessive vibration and increase noise levels.

## Orientation



The heat pump is designed for open air operation, requiring sufficient air supply to maintain operating efficiency.

The air inlet and outlet of the heat pump must be positioned away from prevailing winds and must be provided with sufficient clearances as shown on the next page.

Consideration to the orientation of the control interface is important as the homeowner / end user will need adequate room to view and interface with the control pad.

## Accessibility



The heat pump **MUST** be installed in a vertically upright position. All components must be accessible without the use of a ladder or scaffold.

Ensure the pressure and TPR valve, and any access covers have sufficient clearances and are accessible for service and removal. The information on the rating plates **MUST** also be readable.

## Base requirements



The heat pump must be installed in an upright position on a **level, stable** and water impervious base. The base must be capable of withstanding the weight of a full system. The structure must not shift.

Consideration should be given to the cylinder and base to prevent water ponding on the base and installations should allow water to drain and dry. Ensure the HydraHeat does not stand on permanently wet surfaces.

Where there is potential of damage occurring from a leaking system, a suitably drained safe tray is fitted as per AS/NZS 3500.4 5.4 and G12/AS1 6.11.3.

## Snow zone locations



In areas where heavy snowfalls are expected, ensure the unit has snowfall protection over the top of the air outlet. Ensure that the minimum clearances listed on the following page are adhered to.

# Clearances (mm)

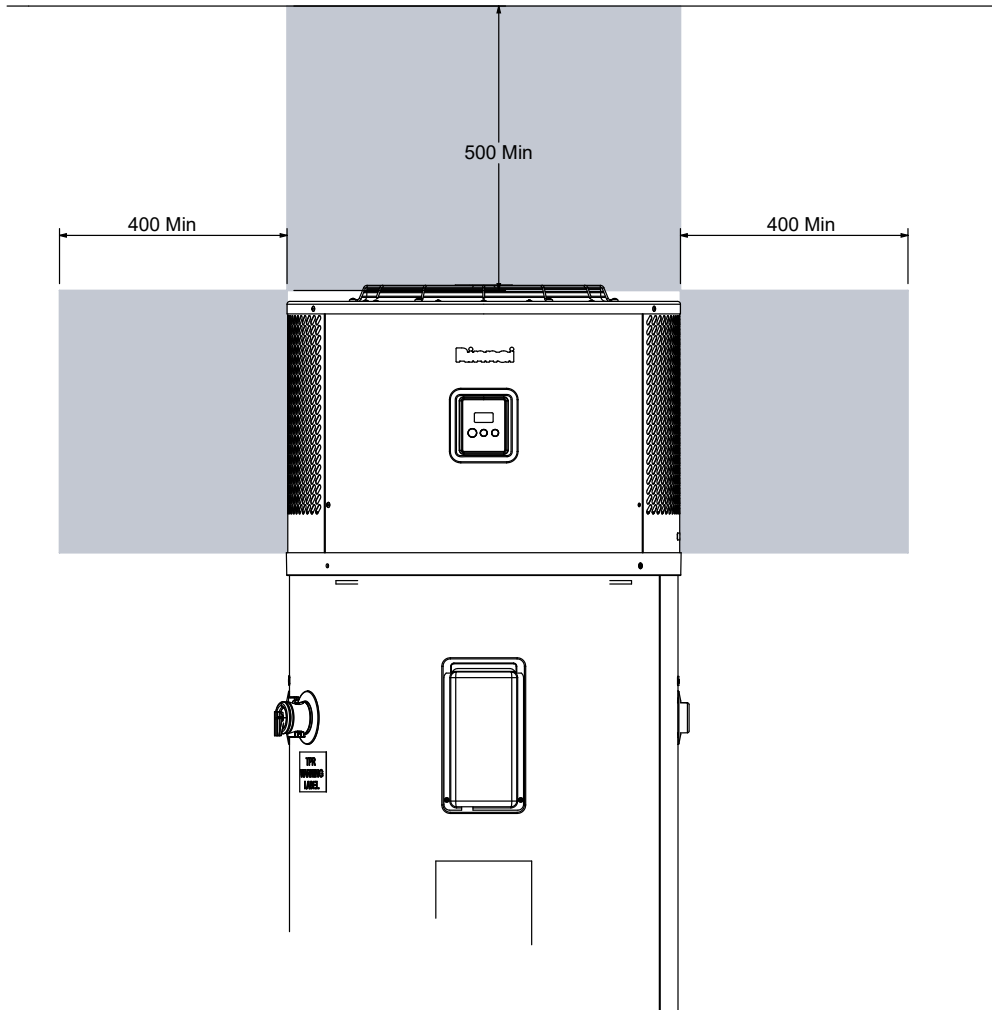
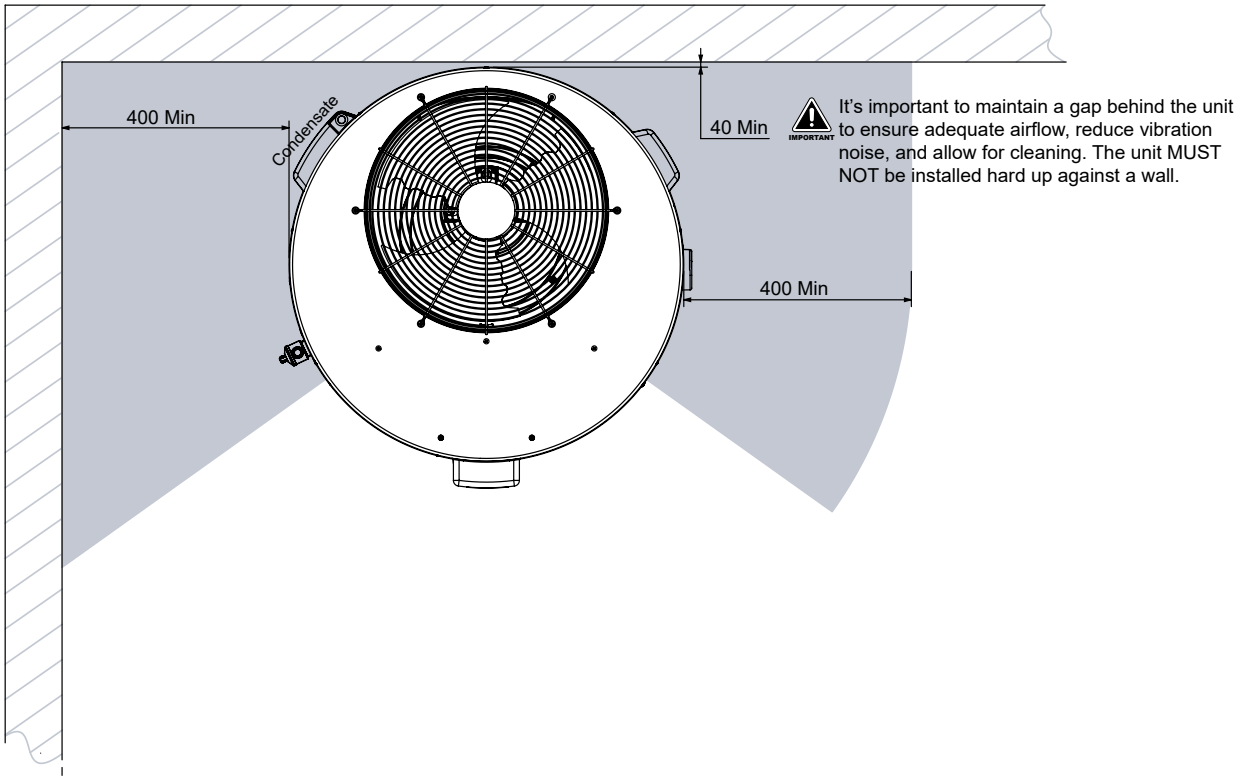

# Connections and plumbing arrangement

The cylinder component of the system must be installed in accordance with G12/AS1, and AS/NZS 3500.4. For service and maintenance, please allow sufficient room for access to covers and valves. All pipe work should be insulated with polythene foam or equivalent insulation to optimise performance and energy efficiency. This includes all water fittings.

All hot water supply parts must comply with AS/NZS 3500.4 and G12/AS1.

For an appliance intended to be permanently connected to the water mains and not connected by a hose set.



- The valve or drain valve outlet pipe must not be sealed or blocked.
- Valves with pressure ratings other than those listed in this manual must not be used.
- A discharge pipe connected to the pressure relief device is to be installed in a continually downwards direction and in a frost free environment.



## Important

- DO NOT use thread tape on any of the connections, this can break down and cause blockages in the system.
- Strainer must be installed in the system.
- Ensure both insulated caps supplied with the unit are used on the plugged inlet and outlet ports.

TPR

**Outlet port** (hot water to property)  
Hot water connections: 20 mm BSP female connection

**Inlet port** (cold water from mains)  
Cold water inlet 20 mm BSP female connection. A drain off tap or line must be fitted to the inlet of the water heater.

If the water pressure exceeds the rated pressure, a pressure reducing valve is to be fitted to the installation.

Insulate all water pipes and connections to prevent freezing.

**Condensate:** During normal operation, condensation occurs in the heat pump as air across the evaporator is cooled. In high humidity locations a large volume of condensate can be generated, this needs to be plumbed into a condensate drain and gully trap—19 mm tapered connection, clear flexible PVC drain hose—installer to provide.

Condensate position is on the top left, refer top view drawing on previous page.

### Drain valves

In accordance with AS/NZS 3500.4 5.11.3, drain lines from temperature / pressure-relief valves, expansion control valves and tundishes shall be installed and located so as not to cause a nuisance, is readily discernible and incurs no risk or damage to the building (including slabs and footings) or injury to persons. Discharging drain lines or TPR relief lines onto the base is not advised as over time water discharge can adversely affect the cylinder.

### TPR valve (850 kPa, 99 °C, 10 kW)

The supplied TPR valve must be installed to ensure safe operation. Failure to do so can potentially cause injury and damage the unit.

The TPR valve should be connected to a vertical discharge pipe that enables water to flow downwards at all times. The TPR discharge pipe outlet should be positioned such that the outlet hot water cannot cause injury to persons or damage to the building. It should be insulated with the black moulded insulation pieces (and clip ties) provided with the cylinder to reduce heat loss.



TPR insulation

### Safe tray

Where there is potential of damage occurring from a leaking system, a suitably drained safe tray is fitted as per AS/NZS 3500.4 5.4 and G12/AS1 6.11.3.

### Pipe work

It is the installer's responsibility to adequately size the distribution pipe work in a property to ensure sufficient performance from all outlet fittings. Water pipe sizing should be performed in accordance with AS/NZS 3500.4 and/or G12/AS1. Pipe sizing and valve selection must be performed to allow for the water supply pressure.

DO NOT drill anything into the water heater, this could damage critical components and cause corrosion.

### Seismic constraint - cylinder component of the system

NZBC B1.3.2 requires building elements (including *storage water* heaters) to be adequately supported including support against earthquake forces.

Each of the following is an acceptable solution to B1.3.2 for a HydraHeat water heater installation.

	Acceptable solution	Clause or referenced standard	Section of referenced document
1	G12/AS1	6.11.4 Structural Support: Figure 14	
2	G12/AS3	AS/NZS 3500.4:2021: 5.5.4 Seismic restraints, Figure 5.5.4 <sup>1</sup>	
3	G12/AS3	AS/NZS 3500.4:2021: Section 5.5.4	NZS 4607, Section 202: Fig.1 / Table 1

<sup>1</sup> Figure 5.5.4 Typical arrangement for seismic restraint of storage water heaters less than 350 L (New Zealand only)

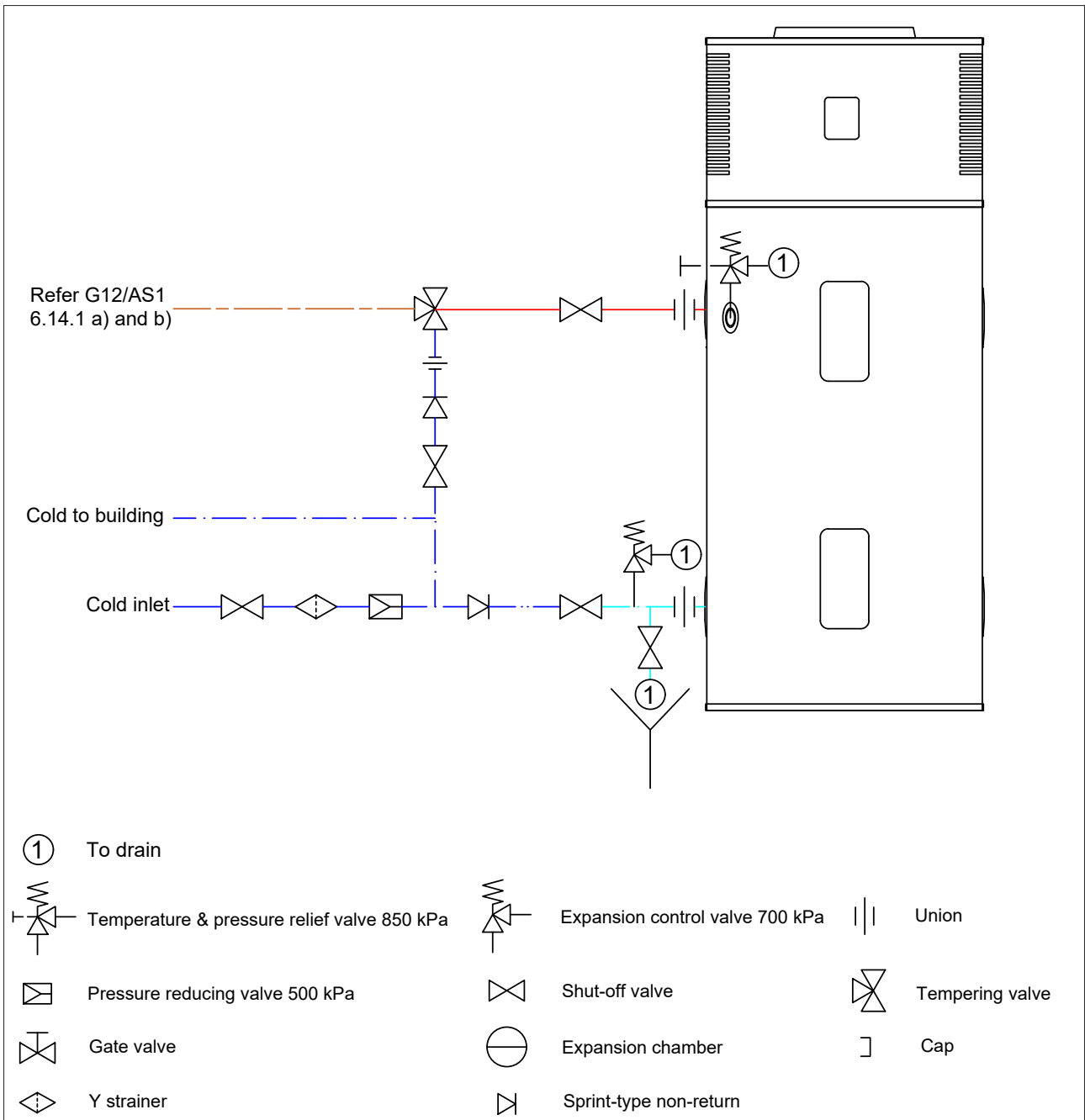

Ensure a strainer is installed. If not, debris could block the non-return valve. This will stop the flow and cause the heat pump to stop operating.

# Storage and delivery temperatures



**WARNING**

- The access cover to the element and the thermostat must only be removed by an electrician or other suitably qualified tradesperson.
- Thermostat settings must only be adjusted by an electrician or other suitably qualified tradesperson.

## Hot water temperatures

NZBC G12.3.6 states that “Where hot water is provided to sanitary fixtures and sanitary appliances, used for personal hygiene, it must be delivered at a temperature that avoids the likelihood of scalding.”

In order to prevent scalding the delivered hot water temperature at any sanitary fixture used for personal hygiene must meet:

- G12/AS1 6.14.1 a)
- G12/AS1 6.14.1 b)

Sanitary fixtures used for personal hygiene includes showers, baths, hand basins and bidets.

In kitchens and laundries, heated water must be delivered to fixtures and appliances at flow rates and temperatures which are adequate for the correct functioning of those fixtures and appliances. The temperature required may be greater than 50 °C.

To comply with these requirements, a temperature limiting device, such as a tempering or thermostatic mixing valve will be required on standard residential installations.

## Cylinder thermostat



**IMPORTANT**

The cylinder thermostat is factory set to 70 °C to ensure proper operation of the ‘Element only’ mode and disinfection cycles. This setting **MUST NOT** be adjusted—any changes will void the warranty.

## Legionella disinfection

The HydraHeat incorporates a built-in automatic disinfection cycle to comply with the legionella<sup>1</sup> requirements of AS 3498<sup>2</sup>. In this cycle, the water in the cylinder is heated above 60 °C for 32 minutes each week. Depending on the mode of operation, this can be achieved using either the electric element, or the heat pump.

During legionella disinfection, ‘L’ will appear on the main display. This function cannot be switched off or disabled.

<sup>1</sup> Legionella is a bacterium that can cause Legionnaires’ disease—a severe form of pneumonia.

<sup>2</sup> AS 3498: Safety and public health requirements for plumbing products - Water heaters and hot-water storage tanks.

# Water quality

Water quality MUST:

1. Meet the Water Services (Drinking Water Standards for New Zealand) Regulations 2022 and the Aesthetic Values for Drinking Water Notice 2022, or the water standards as statutorily defined at the time; AND
2. Be within the limits shown in the table below.

Water quality outside these limits will void this warranty.

## Water quality and impurity limits

<b>TDS (Total Dissolved Solids)</b>	<600 mg/L	<b>Manganese</b>	<0.01 mg/L
<b>Total Hardness CaCO<sub>3</sub></b>	<200 mg/L	<b>Sodium</b>	<150 mg/L
<b>Alkalinity</b>	150-200 mg/L	<b>Iron</b>	<0.1 mg/L
<b>Dissolved (free) CO<sub>2</sub></b>	<25 mg/L	<b>Sulphate</b>	<100 mg/L
<b>pH</b>	6.8-7.5	<b>Nitrate</b>	<11 mg/L
<b>Chlorides</b>	<150 mg/L	<b>Alkalinity/Sulphate ratio</b>	>1
<b>Free Chlorine</b>	<1 mg/L	<b>LSI<sup>1</sup></b>	-1.0-0.8 @20 °C
<sup>1</sup> Langelier Saturation index—scaling potential of water			

## Water quality warranty guidelines

### Filtration

Where there is discolouration, debris, or silt present in the water, an inline filter must be fitted into the water supply to protect the copper in the HydraHeat head unit from corrosion, and wear on the circulating pump. Particulates and deposits in hot water systems are corrosive to copper and stainless steel and can lead to premature pitting. The filters must be periodically replaced to maintain the integrity of the system.

### Stagnation

Leaving water stagnant in the system will promote corrosion. It is recommended that systems, if not in use, are flushed on an eight week cycle.

### Bore and tank water

Bore and tank water supplies should be considered to be corrosive and should be tested prior to using the system. Bore and tank water must meet the water quality parameters stated in the above table.

# Electrical supply and connections

The electrical connection must be carried out by a qualified person in accordance with the latest version of AS/NZS 3000 Wiring Rules.

It MUST have the electric terminals connected to an independent, fused AC 230 V 50 Hz power supply. An isolating switch (lockable) must be installed in accordance with AS/NZS 3000 clause 4.19.

- The power supply to the heat pump module MUST NOT be activated until the system is filled with water. Failure to follow this requirement may result in damage to the wiring in the element due to overheating.
- Household wiring to the system must be capable of withstanding the appliance load.
- Fixed wiring must be protected from contact with the internal surfaces of the system.

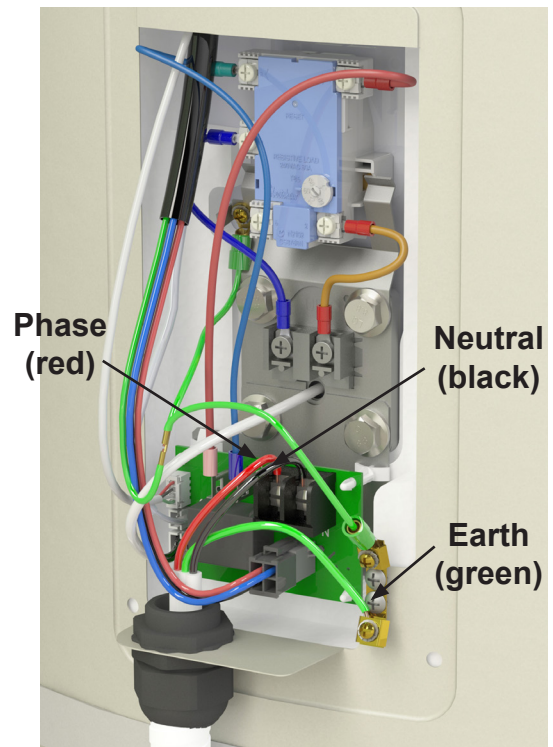

Electrical access for the cylinder is via a hole in the lower element cover for mounting with an approved electrical conduit gland (22 mm, not supplied), this must be installed. For entry to the element cover remove the two fixing screws.



The head unit wiring diagram is on the back of the plastic user interface screen. Refer to p.22 for details on how to connect the head unit to the cylinder—no disassembly required of the user interface.

Electrical access for the tank is via a hole beneath the element cover for mounting with an approved weatherproof electrical conduit gland (not provided). The electrical gland must be installed. For entry into the element cover remove the two fixing screws.

Connect all LIVE, NEUTRAL and EARTH wires in accordance with the wiring diagrams.

Inspect and ensure all wiring links are secure prior to fixing the access cover and turning the power on.

Once the cylinder is full of water perform an Earth Continuity Test, as outlined in Annex A of AS/NZS 60335.1.

**This page intentionally blank**



# Wiring diagram cylinder

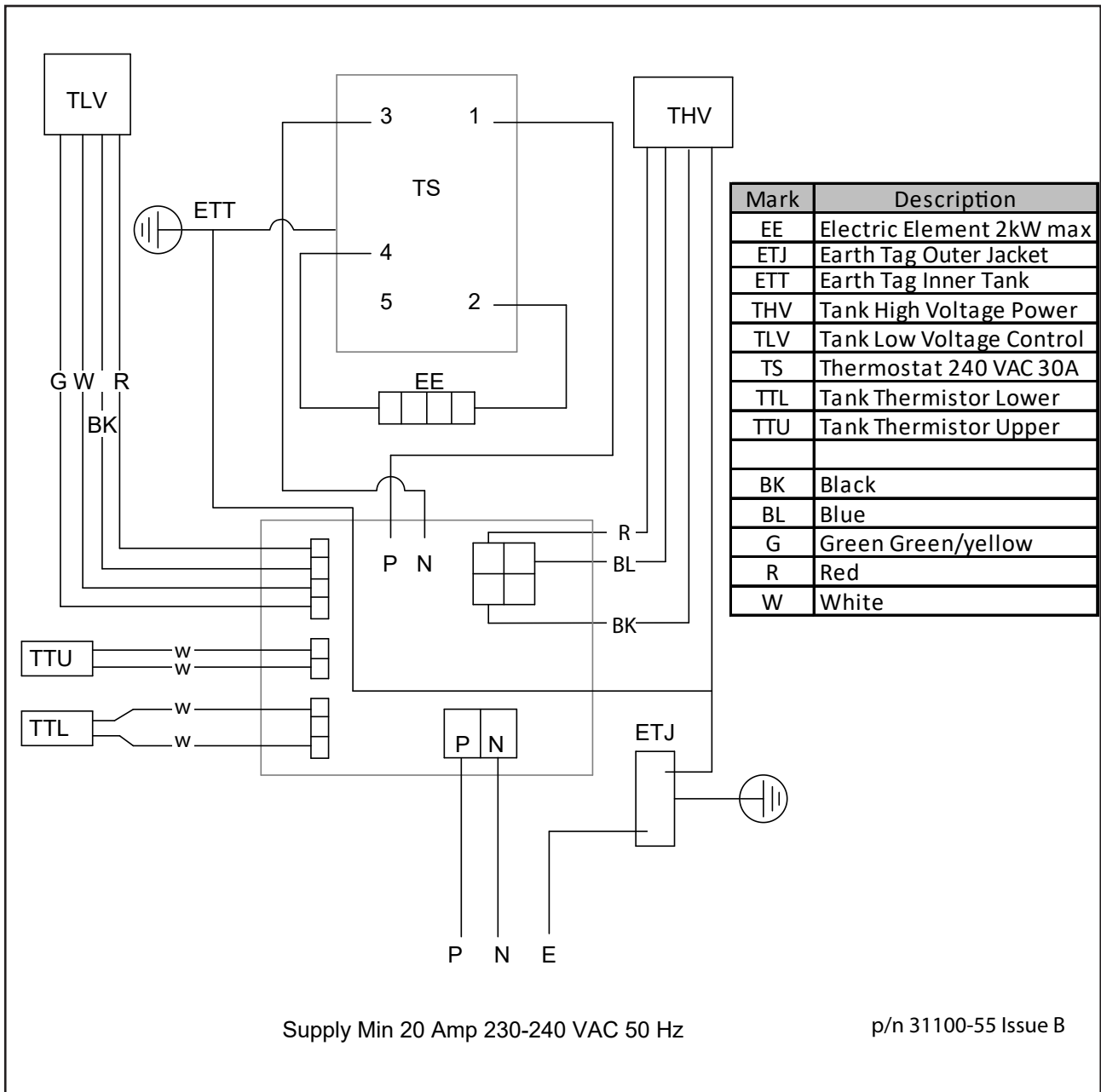

# Connecting the head unit and cylinder

As the system is supplied as two separate components there will be a requirement to connect the head unit heat pump unit to the cylinder. This is a simple process but will initially require two people to lift the head unit onto the tank.

1. Ensure the cylinder is isolated from water and power supplies. If retrofitting, relieve pressure on the cylinder by opening a hot water tap or actuating the TPR for several seconds.
2. Remove the front access panel from the head unit by removing two screws on the lower corners, pull bottom edge of panel out and down to remove. This will expose the connector housing and the head unit hand holds.
3. Remove the one screw from the connector housing, do not open yet.
4. With the assistance of a second person, place the head unit on top of the cylinder. Handle the head unit using the hand holds. Ensure front side of the head unit is aligned with the hose access cover of the tank.
5. Remove the cylinder top cover by removing the two screws.
6. Open the connector housing cover.
7. Retrieve the two braided stainless steel hoses from the head unit. Route the hoses down through the connector housing and down into the cylinder. The hose ends are pre-lubricated.
8. Remove brass cap<sup>1</sup> from left hose port on the cylinder and connect the straight hose. Tighten knurled hose nut to finger-tight.
9. Remove brass cap<sup>1</sup> from right hose port on the cylinder. Connect right-angle hose end to the right hose port. Tighten knurled hose nut to finger-tight.
10. Fill the system, refer instructions on p.25.
11. Electrically connect the head unit to the cylinder. Retrieve low-voltage and high-voltage wiring connectors from hose access port. Connect high and low-voltage connector to corresponding connectors from the PCB enclosure.
12. Commission, refer p.25. Replace cylinder cover.
13. Replace head unit front panel.
14. Fix the head (holes located around bottom edge of unit) to the cylinder using the four supplied self drilling screws (images on p.24). Use a Phillips driver in a battery drill. **DO NOT OVERTIGHTEN.**



When connected there is an approximate five minute delay until the system kicks into action, this lag is designed to protect the compressor so it doesn't short cycle. To override the startup delay press the down (v) and back (<) buttons simultaneously, there will be a confirmation beep, and the compressor will start.

<sup>1</sup> Brass caps should be left in the bottom of the top housing in case it needs to be capped at a later date for maintenance and servicing.



Head unit front panel removed to expose hand holds and connector housing.



Cylinder connector housing flap down and flap open. Leave closed until head unit is fitted.

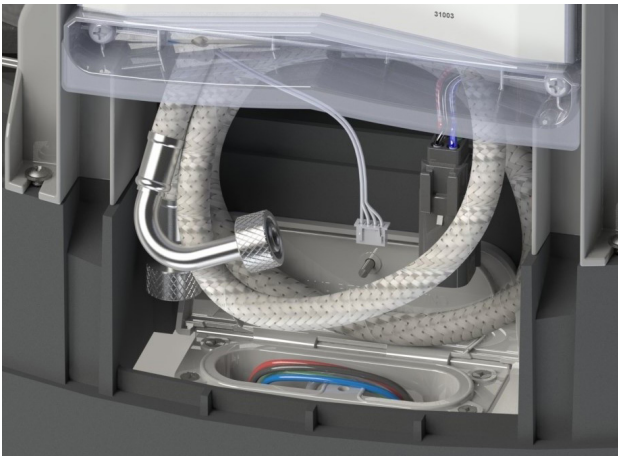

Heat pump hoses and electrical connections ready for connection to cylinder.



Cylinder supplied as a stand alone component, but ready for connection to the heat pump.



Heat pump hoses down through connector housing

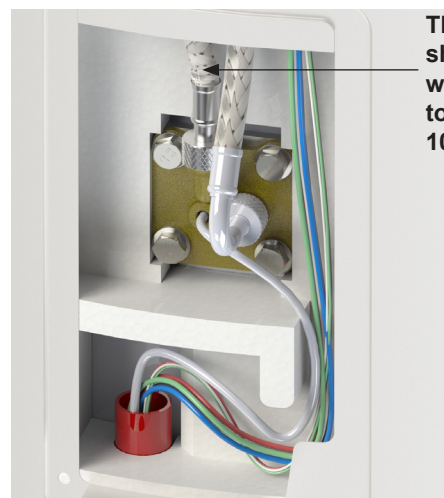

**This pipe should be warm to touch after 10 minutes**

Heat pump hoses connected in the cylinder. Ensure there are NO KINKS in the hoses. Kinks can reduce the flow and cause a T1 fault.

- Fix head to cylinder using the four supplied self drilling screws (9136).
- Use a Phillips driver in a battery drill.
- DO NOT OVERTIGHTEN.



# Commissioning



Commissioning, filling and draining must only be carried out by an authorised person. Make sure the cylinder is full of water before energising the system. Failing to do this can cause irreparable damage to the element and sensors.

## Filling the system

1. Open hot water tap at the sink.
2. Open the cold water isolation valve to the system. Allow the system to fill and the air to bleed through the tap.
3. Turn off the hot tap at the sink when water flows freely without any air bubbles or air bursts.
4. Check for leaks and rectify if detected.
5. Bleed any remaining air from the TPR.
6. Turn on power to the heat pump unit and wait 30 seconds for the circulation pump to turn on. Any remaining air will be bled from the automatic air vent. The heat pump will start after approximately five minutes.

## To turn off the system

It may be necessary to turn off the system after installation and commissioning, for example during building activities or if the premises are vacant.

1. Switch off the electricity supply at the isolating switch to the system.
2. Close the water isolation valve at the inlet to the water heater.
3. Drain if there is a risk of freezing.

## To drain the system

1. Turn off the system as above.
2. Open all the hot water taps.
3. Gently open the TPR valve, this will relieve pressure in the system.
4. Open the drain valve—make sure no damage/injury will occur from discharged water.
5. Open the TPR valve again. This allows air into the system and will result in the cylinder draining.

## Operation sequence

When the power supply turns on, the heat pump control system starts. After approximately 10 seconds the heat pump unit will display and show 'STANDARD 60C'. If this is the desired mode, then nothing needs to be done. Alternatively another mode can be selected.

The heat pump will wait five minutes before the compressor starts. Alternatively, press and hold the two rightmost buttons (arrow keys) on the display simultaneously to override the starting delay.

The heat pump unit will heat the internal condenser to 50 °C and then the circulating pump will start. This normally takes 5-10 minutes. Wait an additional 5 minutes to ensure the heat pump is delivering water constantly at the set point temperature.

## Controller sequence

When connected to mains power for the first time the back light of the controller will come on, and after a couple of seconds the Rinnai logo will appear. The controller will then default to showing 'Standard' operation which is the preset mode of operation. If no buttons are pressed after 30 seconds the controller will go into standby (nothing displayed on the controller). Pressing any button on the controller will turn the controller back on.

For further detail on the controller and setup, refer to p.30.



Approximately ten minutes after the system has been powered, and before leaving ensure the:

- Cylinder is full of water
- Head unit is connected correctly
- Compressor and fan are operating
- Hot water return (left hand hose) is warm, do this by lightly touching the hose
- Display is operating with no fault conditions



If the system cannot be made to perform correctly please contact Rinnai.

NOTE

## Customer handover



Explain to the customer about the use, care, service and maintenance of the system, and ensure they understand the instructions. Make sure you leave this installation guide with them as it contains important information about their system.

# Error / warning codes

When the system encounters an event, a code will display on the screen, and the unit will beep once every 5 seconds. The most common installation errors are electrical connection faults, T1, S8, and S9 faults, for which rectification actions are detailed below. If other codes are detected, refer to the service manual and contact Rinnai for advice and additional troubleshooting actions.



During legionella disinfection, and when in defrost, 'L' and 'D' will appear on the main display—these are not fault codes.

Code	Event / fault description	Possible cause	Action
-	Unit does not turn on	No power to cylinder	Check connection to mains power, and check the cylinder isolator is on. Check circuit breaker in distribution board is on.
		Loose or broken wiring connection	High voltage cylinder harness properly connected to cylinder PCB.
			High voltage cylinder harness properly connected to high voltage cylinder harness
			High voltage cylinder connection harness properly connected to main PCB
		Blown fuse	Check PCB fuse for continuity. Replace if faulty.
Display not visible	Timeout has occurred, press OK. If the system has been set to an operation mode, then it is locked. To unlock press and hold the OK button for 3-5 seconds. If still not visible, power cycle the unit.		
T1	Condenser over temperature	Insufficient or zero water pressure	Check the cylinder is filled with water and the inlet isolation valve is open. Power cycle the heat pump to restart the unit. If the fault reoccurs and the water pressure to the unit is above 100 kPa, follow the purging procedure under 'Airlock in the head unit inlet line' below.
		Water flow to head unit impeded or blocked	Check there are no kinks in the connecting hoses. Ensure water hoses are properly connected to the cylinder connector flange.
		Head unit not hydraulically connected to the cylinder	Check that the head unit is connected to the inlet and outlet of the cylinder connection points. If not, close the inlet isolation valve, relieve the pressure via the TPR, remove the two caps on the cylinder heat pump water connections, connect the two flexible hoses to the cylinder connections provided. Open the cylinder isolation valve.
		Airlock in the head unit inlet line	Check that the head unit is connected to the inlet and outlet of the cylinder connection points. Check that the cylinder is filled with water. Check that the isolation valve to the cylinder is open. Power cycle the heat pump. If the same fault occurs, manually purge the piping of air, refer p.29. Power cycle the heat pump and wait until the heat pump is stabilised. Use real-time view of the technician app to investigate.
S8	Lower cylinder temperature sensor fault	Wiring plug not inserted properly. Loose or broken wiring connection.	Check that the low voltage cylinder harness is plugged into the low voltage plug on the head unit. Check that the plug is fully inserted, the lock tab should be fully home in the receptacle.
S9	Upper cylinder temperature sensor fault	Wiring plug not inserted properly. Loose or broken wiring connection.	Check that the low voltage cylinder harness is plugged into the low voltage plug on the head unit. Check that the plug is fully inserted, the lock tab should be fully home in the receptacle.
		Defective sensor or connection	Contact Rinnai.
E1	Element not running	No power to element	Check power to the element and confirm if the thermostat is properly wired to the cylinder PCB and element
		Defective thermostat	Check input and output of the thermostat.
		Element is burnt out	Check element resistance, should be ~25 Ω
E1 is a warning indicator regarding the cylinder element, the heat pump will operate as normal.			
E4	High electric heater power consumption	Incorrect element size, power surge, element faulty/shorted	Check element size (has it been changed?), check power connections and resistance on element. Refer to service manual and use technician app to investigate.

For the below error codes, contact Rinnai for advice and additional troubleshooting actions.

Fault code	Event / fault description	Possible cause	Action
00	No active fault		Refer to service manual
01	Real time clock fault, not reading correctly	Flat battery and power cut	Call an electrician or Rinnai service to replace the battery (not a user serviceable part).
S1	Ambient sensor fault	Sensor faulty / not detected	Contact Rinnai
S2	Water inlet sensor fault	Sensor faulty / not detected	Contact Rinnai
S3	Water outlet sensor fault	Sensor faulty / not detected	Contact Rinnai
S4	Compressor discharge sensor fault	Sensor faulty / not detected	Contact Rinnai
S5	Condenser sensor fault	Sensor faulty / not detected	Contact Rinnai
S6	Suction sensor fault	Sensor faulty / not detected	Contact Rinnai
S7	Evaporator (pressure) sensor fault	Sensor faulty / not detected	Contact Rinnai
T2	Evaporator under temperature	Unit not defrosting, low refrigerant charge, evaporator blocked	Refer to service manual and use technician app to investigate. Visually look for wall clearance and any blockages.
T3	Low super heat fault	Evaporator blocked, faulty sensor	Refer to service manual and use technician app to investigate.
T4	Low water temperature fault	Low refrigerant charge, fan fault, inadequate wall clearance, water inlet temperature too low	Refer to service manual and use technician app to investigate. Visually look for wall clearance and any blockages.
T6	Discharge over temperature	Low refrigerant charge, worn compressor, loose/faulty EEV coil	Refer to service manual and use technician app to investigate.
F1	Fan not rotating	Fan blade blocked, fan water damage	Visually look for blockages. Refer to service manual and use technician app to investigate.
F2	Fan over speed	Overspeed conditions (> 1000 rpm)	Refer to service manual and use technician app to investigate.
P1	Pump is not rotating	Pump obstructed or jammed due to debris or ice	Refer to service manual and use technician app to investigate.
P2	Pump over speed	Overspeed conditions (> 12400 rpm)	Refer to service manual and use technician app to investigate.
C1	Compressor not running	Faulty capacitor, internal wiring, PCB sensor	Refer to service manual and use technician app to investigate.

### T1 fault

A T1 fault on operation could indicate no flow and/or an overpressure fault. Ensure that the air vent is not blocked. Also check there are no kinks in the connecting hoses. They need to be straight like those shown below.

**Correct position**  
(air vent cap partially open)



**Incorrect position**  
(vent cap closed)



**Connecting hoses**  
Ensure they are straight and not kinked



# Manual purging procedure

Required where a T1 fault has occurred on startup due to an airlock in the system.

1. Remove the top cylinder cover to expose the hoses and cylinder flange.
2. Turn off the isolation valve to the hot water cylinder, and relieve the pressure via the TPR. Unscrew the hot water flexible hose—the one with the straight end as shown below.
3. Screw the brass cap back onto the cylinder flange hot connection. Place a bucket under the hot water hose.

Open the cylinder isolation valve and allow water to purge through the head unit and into the bucket. After three seconds of water flow, close the cylinder isolation valve.

4. Remove the brass sealing cap and place at the bottom of the polystyrene housing for future use. Then screw the hot water hose back on again and turn on the cylinder isolation valve.
5. Power up the heat pump. Press the (v) and back (<) buttons simultaneously to override the start up delay.

Wait until the unit has been producing hot water for three or more minutes (this can be checked by touch). Replace the top cover using the two screws provided.



# Controller interface

The HydraHeat controller uses a compact OLED display with three capacitive touch buttons to enable easy access to the operation menus. When a button is pressed there will be an audible beep.



## Home screen and navigation

To access the home screen press OK for approximately 3-5 seconds. The screen will show the current operating mode, which is set to 'Standard' by default.

The display will automatically turn off after 30 seconds, but can be reactivated again by pressing any of the buttons.

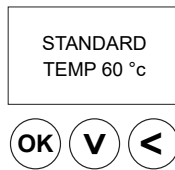

- MODES
- SET DAY / TIME
- SET TIMER
- FACTORY RESET

- Down button - scrolls through the different menu options
- OK button - selects the option
- Back button - returns to the previous screen



## Operation modes

Press the down button to cycle through the screens to select the mode of operation required. Select OK to confirm. Once the mode is selected, the screen will display the modes in the order shown below. The operation modes are spread over two screens.

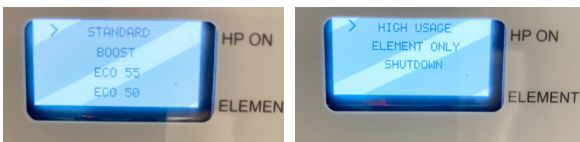

<b>STANDARD</b> BOOST ECO 55 ECO 50	STANDARD <b>BOOST</b> ECO 55 ECO 50	STANDARD BOOST <b>ECO 55</b> ECO 50	STANDARD BOOST ECO 55 <b>ECO 50</b>	<b>HIGH USAGE</b> ELEMENT ONLY SHUTDOWN	HIGH USAGE <b>ELEMENT ONLY</b> SHUTDOWN	HIGH USAGE ELEMENT ONLY <b>SHUTDOWN</b>
STANDARD TEMP 60 °C	BOOST TEMP 70 °C	ECO 55	ECO 50	HIGH USAGE TEMP 70 °C	ELEMENT ONLY TEMP 70 °C	SHUTDOWN

## Day and time

- MODES
- SET DAY / TIME**
- SET TIMER
- FACTORY RESET

This only needs to be done during daylight savings, or if the factory set day and time settings are lost, for example if a 'Factory reset' has been done. The clock is a 24-hour clock.



Once in 'Set Day / Time' press and hold the down button to scroll through the day, hour, and minutes to edit, press OK to confirm selection at each stage.

## Using the timers

The HydraHeat features two programmable timers that operate within a 24-hour period. You cannot overlap operating times within a 24-hour period. Once programmed, the timers will repeat every day until 'Timer Reset' is selected.

Before setting the timers ensure the day and time are correct, refer previous page.

The timers in most instances are used to stop the heat pump from operating during selected times, or to run the heat pump in another mode, for example in Eco mode. In shutdown mode, while a timer is active, the system remains in standby and will not heat water.

### Important



Hot water heat pumps require a continuous power supply for at least 6-8 hours a day to enable the appliance to make sufficient hot water and to allow the legionella disinfection cycle to run and fully complete. If the operating time is restricted, for example only being on during a free hour of power, then there will be limited hot water production. The appliance can only heat as much water as the available operating time allows.

### Example 1 – Reducing noise overnight

If the heat pump is located near a bedroom, you may wish to prevent it from operating overnight.

Required timer setting:

- 10:00 pm – 6:00 am, mode is in shutdown

The heat pump can operate outside these hours as required.

Tip: Always use the down arrow button to navigate and change the times, the back arrow button returns you to the previous screen.

### How to set

1. Press and hold OK for three plus seconds to access the home menu.
2. Select SET TIMERS, press OK.
3. Select SET TIMER, press OK.
4. Set the TIMER 1 start time (hours, then minutes), pressing OK after each selection.
5. Set the TIMER 1 end time (hours then minutes), pressing OK after each selection.
6. Select SHUTDOWN as the mode, press OK.
7. When ENABLE T2? is displayed, select no, then press OK.
8. Use the back button to go back to the home menu.

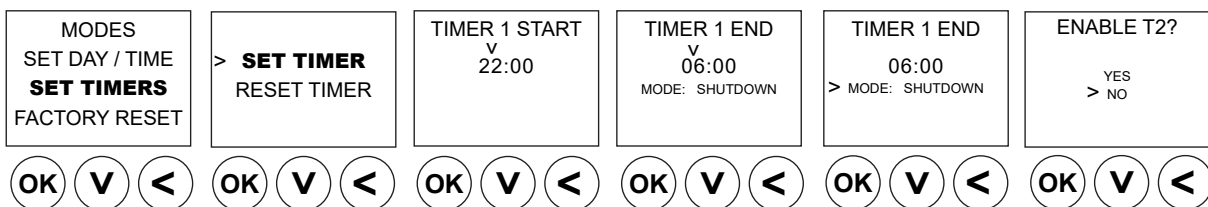

## Example 2 – Using two off-peak electricity periods

If your electricity tariff has two off-peak periods:

- Off-peak 1: 11:00 am - 5:00 pm
- Off-peak 2: 11:00 pm - 7:00 am

Set the timer to stop the heat pump during the peak-rate periods. Required timer settings:

- 5:00 pm - 11:00 pm
- 7:00 am - 11:00 am, mode is in shutdown

This allows the heat pump to operate only during the available off-peak periods.

### How to set

1. Press and hold OK for three plus seconds to access the home menu.
2. Select SET TIMERS, press OK.
3. Select SET TIMER, press OK.
4. Set the TIMER 1 start time (hours, then minutes), pressing OK after each selection.
5. Set the TIMER 1 end time (hours then minutes), pressing OK after each selection.
6. Select SHUTDOWN as the mode, press OK.
7. When ENABLE T2? is displayed, select yes, then press OK.
8. Set the TIMER 2 start time (hours, then minutes), pressing OK after each selection.
9. Set the TIMER end time (hours, then minutes), pressing OK after each selection.
10. Select SHUTDOWN as the mode, press OK.
11. Use the back button to go back to the home menu.

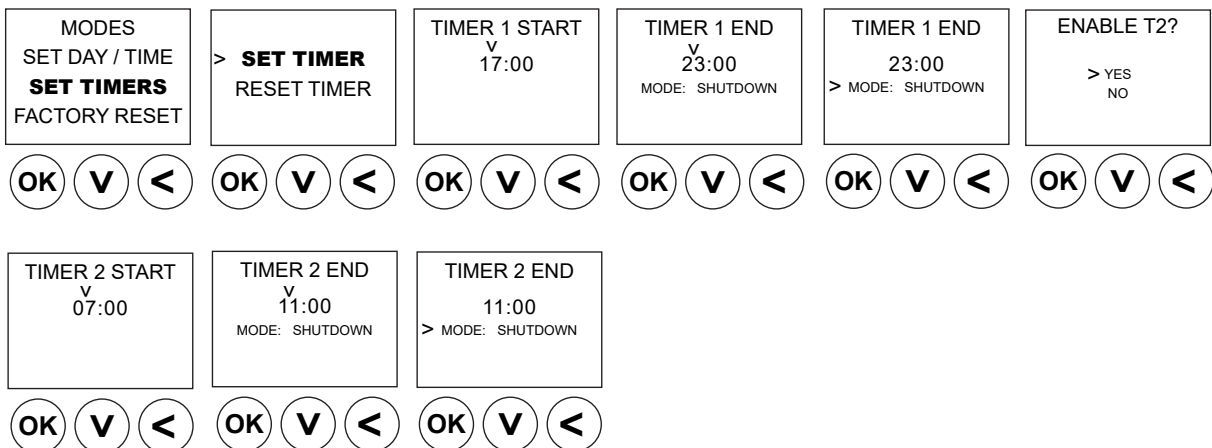

---

## Reset timer(s)

1. Select 'SET TIMERS', and press OK.
2. Use the down button to select 'RESET TIMER', and press OK.
3. Confirm 'YES', and press OK. This will reset ALL timers.

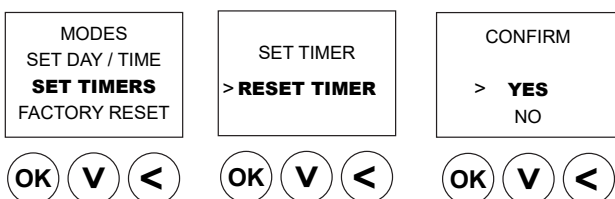

## Factory reset

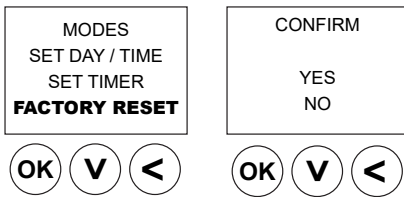

A factory reset clears the date, time, and any set timers, retaining only the default STANDARD mode setting. After a factory reset, you will need to reconfigure the date and time for the timer functionality to work properly.

---

## Locking / Unlocking the screen

To lock the screen press and hold both the OK and Back buttons for more than five seconds. The screen will display 'Locked' and then return to the current operation mode after a short delay. To unlock and access the main menu, press and hold the same two buttons again.

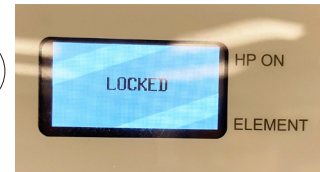
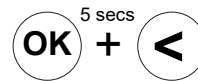

# Appendix: Commercial concept sketches



This high level sketch is for illustrative purposes only and does not show all components required for a complete system. For ring main installations please contact our **commercial team** for a detailed plumbing schematic.

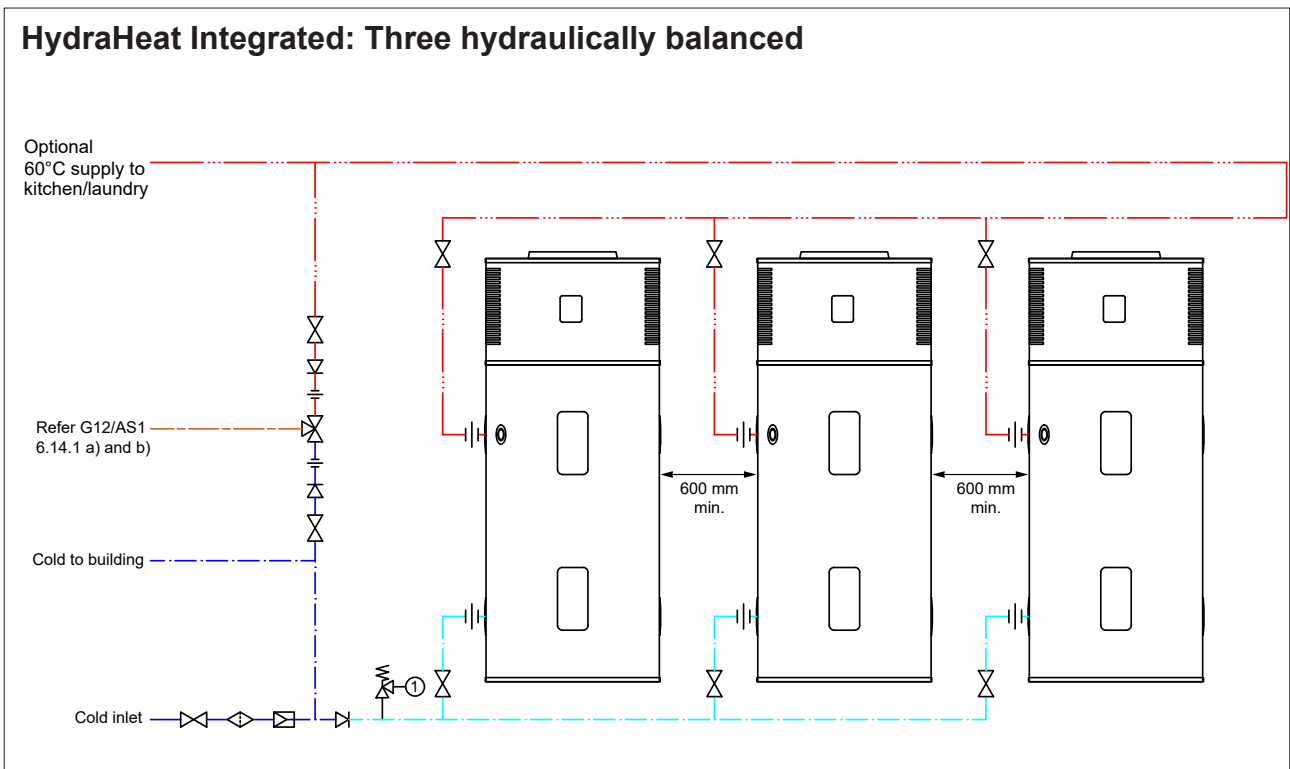
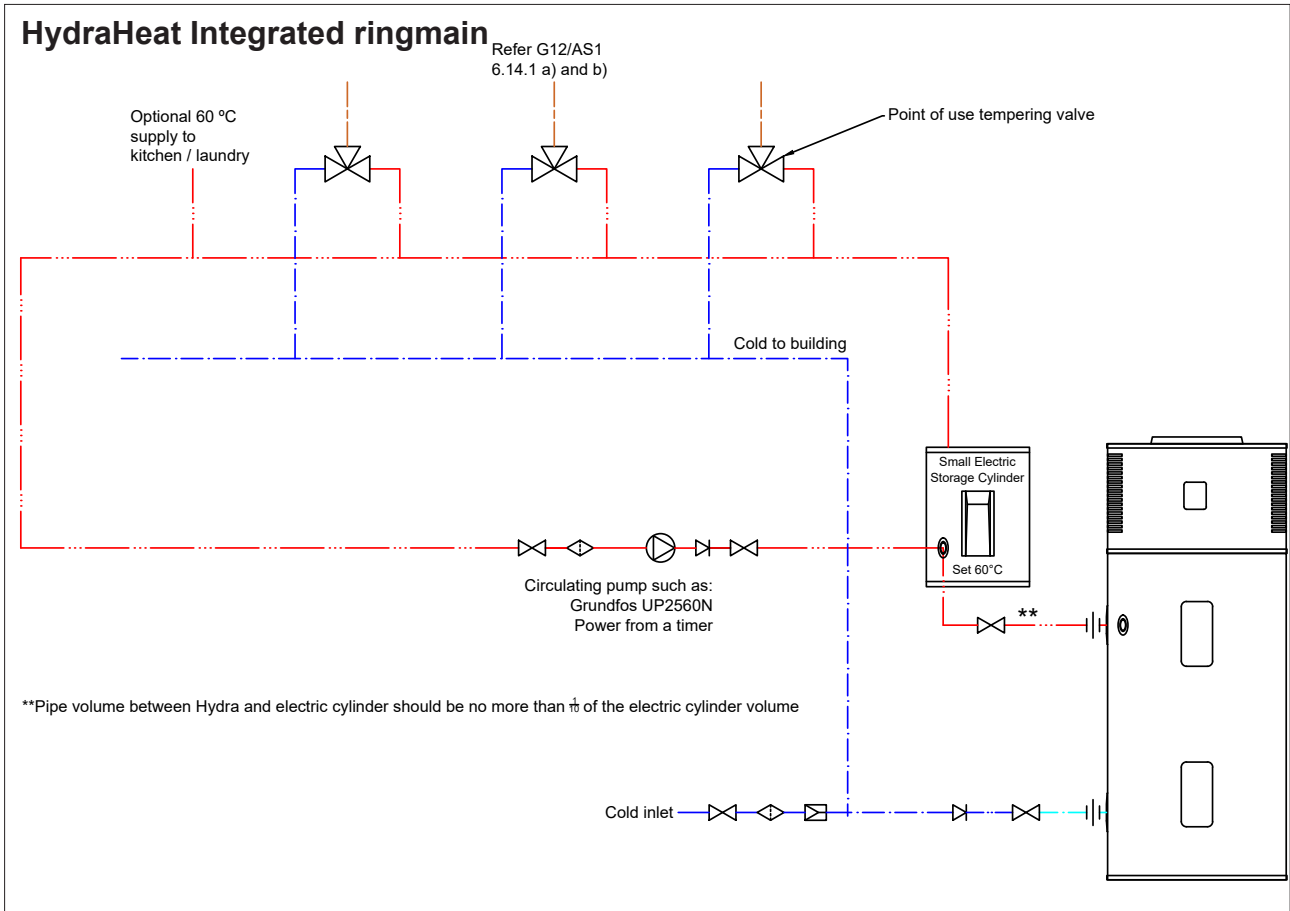



**Rinnai.co.nz**

Tel: 0800 746 624

<http://www.youtube.com/rinnainz>

<http://facebook.com/rinnainz>

Rinnai HydraHeat Integrated installation guide 31114-M