

Models: RHFE0800, RHFE1000, RHFE1500

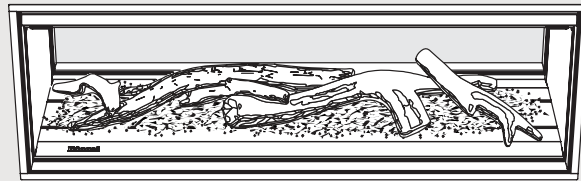
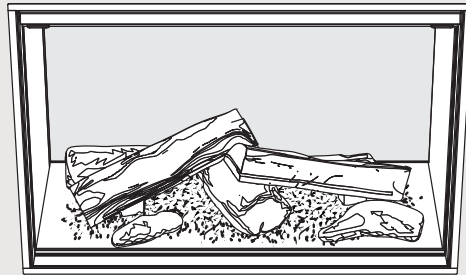

Linear collection gas fireplaces

Installation guide

Rinnai

Important

Appliance must be installed with a Rinnai approved flue system.

This appliance shall be installed in accordance with:

- Manufacturer's installation instructions

Current:

- AS/NZS 5601 Gas Installations
- AS/NZS 5263 Gas Appliances General Requirements
- AS/NZS 3000 Electrical Standards
- AS/NZS 3500 Plumbing and Drainage Standards

Appliance must be installed, commissioned, serviced, and removed by an authorised person, being in New Zealand a licensed gasfitter.

Warning

Improper installation, adjustment, alteration, service or maintenance can cause property damage, personal injury or loss of life.

For more information about buying, using, and servicing of Rinnai appliances call: 0800 RINNAI (0800 746 624).

Rinnai New Zealand Limited
105 Pavilion Drive, Mangere, Auckland
PO Box 53177, Auckland Airport, Auckland 2150

Phone: (09) 257 3800
Email: info@rinnai.co.nz
Web: rinnai.co.nz
[youtube.com/rinnainz](https://www.youtube.com/rinnainz)
[facebook.com/rinnainz](https://www.facebook.com/rinnainz)

Installer please note



When completing the installation it is ideal to have the homeowner present to test the Wi-Fi connectivity and correct operation of the fire.

Contents

Before you start	4
Specification	5
Unit dimensions	6
Clearances from combustibles	7
Hearths	8
TV installation	9
Installation overview	10
Cavity ventilation for the room temperature sensor	11
Framing dimensions	12
Gas supply.....	16
Room temperature sensor.....	16
Electrical supply.....	17
Flue terminal position	17
Installing the Linear into the cavity	18
Removing the glass front.....	19
Commissioning	20
Wiring diagram	24
Burn media installation	25
Test operation and lighting sequence	26
Check Wi-Fi connection.....	27
Installing the wall lining.....	28

Use in conjunction with
'Installing the wall lining' on p.28

Wall linings and clearances to combustibles

There are some aspects of the wall lining installation that are critical to the safe operation of the appliance. One aspect is the free flow of air around the unit. As there are a myriad of wall lining options a supplementary ['Additional guide to installing wall linings'](#) is available on the Rinnai website.

Before you start

Unpack the appliance and components and check for damage. DO NOT install any damaged items. Check all components have been supplied, refer table below, and that **you have the correct gas type**.



Read these instructions to get an overview of the steps required before starting the installation. Failure to follow these instructions could cause a malfunction of the appliance. This could result in serious injury and/or property damage. There are also some sections in this guide that are critical to a successful installation, for example:

- Preline instructions regarding combustible and non-combustible materials pages 7, 8, 28-35
- Cavity ventilation for the room temperature sensor page 11
- Framing dimensions pages 12-15

Linear boxed dimensions

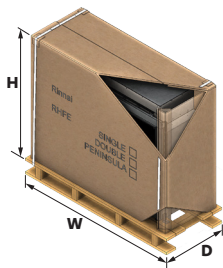

	Linear 800	Linear 1000	Linear 1500
Height	1156 mm	931 mm	931 mm
Width	1350 mm	1550 mm	2050 mm
Depth	530 mm	530 mm	530 mm
Weight	120 kg	125 kg	140 kg

With the Linear engine comes the:

- Glass front with a burn media installation sheet attached
- Remote control (batteries included)
- Flue lock bracket and truss screws
- Operation, installation, burn media, and flue installation guides
- Commissioning sheet (in a plastic pouch inside the unit)
- Reducing flare
- 800/1000 FlameTech log set inside the engine if a Linear 800/1000 is ordered



The burn media for the Linear 1000 (designer log set and crushed glass) and 1500 models will come packaged separately in one large box.



Flue components and accessory items are ordered separately.

Installer please note

The Linear carton has a unit protection cutout that can be fixed to the appliance to protect the fire from damage, debris, and dust, until final commissioning can be completed.

Specification

Inbuilt power flued convection fan fire operated by a simple infra-red remote, or by the Rinnai Wi-Fi app that allows full thermostatic control as well as other features such as timers. Different burn media options available.

Specification summary

	Input (MJ/h)	Output* (kW)	Heating area** (m ²)
800FT 1000FT	15-35	3.5-7.7	71-123
1000	14-34	3.6-7.4	69-118
1500	14-40	3.3-8.5	79-135

* Will vary according to gas type and flue configuration

** Will vary depending on geographical location in NZ

Efficiency = > 75% (all models on high)
Gas type = NG or ULPG

Suitability

Ideal for living rooms and open plan areas. Versatile power flue system makes for easy installation in almost any living space, including bedrooms.

The Linear is ideal for a new build installation.

Installation considerations

Room size—smaller rooms will heat up quickly, and due to the efficiency of the appliance, if in thermostatic mode, will reduce to a low flame profile.

Installation of the Linear higher up the wall, in some room configurations, can create draughts due the convection air being pushed out from the top of the appliance.

Convection fan

2-speed fan. Heat is distributed from the top of the appliance.

Data plate - 1500

Base of the combustion chamber towards the LHS, between the gas control and convection fan access panel.

Data plate - 800/1000

Base of the combustion chamber, LHS, on the convection fan access panel.

Gas connection

½ " BSP, the gas supply terminates inside the unit—lower left hand side of the appliance.

Ignition: Continuous spark electronic ignition.

Noise level: 37-45 dB(A)

Power flue

Inner 50 mm, outer 70~80 mm. Appliance must be installed with a Rinnai flue system.

Power consumption/electrical supply

High = 50 W

Standby = <8 W

The Linear has a 1.5 m power cord with a three pin plug supplied. The power cord passes through a slot in the right hand side of the appliance.

Safety devices

Flame failure sensing system, pressure relief, overheat safety switch, air temperature sensor, thermal fuse, overcurrent fuse, and spark detection.

Temperature control

The Linear can be operated using the basic infra-red remote, or for more features, such as timers and thermostatic control, using Rinnai's Wi-Fi fireplace controller app.

Weights

	Unit	Packaged
800	100 kg	120 kg
1000	100 kg	125 kg
1500	110 kg	140 kg

Unit dimensions

- These are the unit dimensions only, not the framing dimensions
- The centre of the glass is NOT the centre of the appliance
- The viewable glass dimension is the glass INSIDE the lips

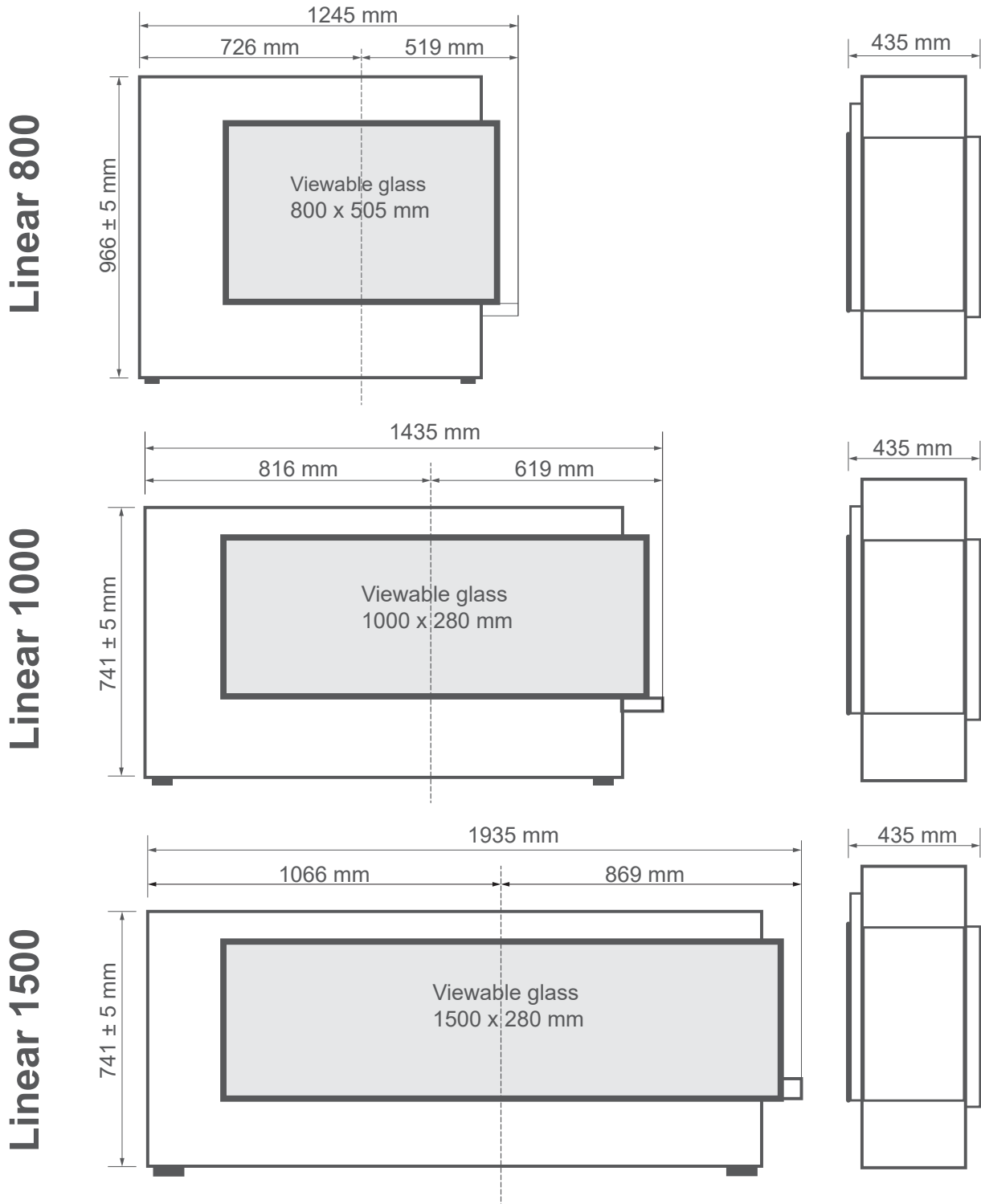

Clearances from combustibles

The clearances listed below, measured from the edge of the glass, are minimum clearances unless otherwise stated.

While the fire is operating

The appliance must not be installed where curtains or other combustible materials could come into contact with the fire. The 400 mm side clearance includes side walls. The 1000 mm clearance is in front of the fire.

Floor protection

Heat emanating from this fire may over time affect the appearance of some materials used for flooring, such as, carpet, vinyl, cork or timber. This may be amplified if the air contains cooking vapours or cigarette smoke. To avoid this occurring, it is recommended that a mat be placed in front of the appliance.

Mantels and surrounds

Combustible mantels and surrounds require clearance from the unit to minimise the risk of fire.

Mantels and surrounds, made of combustible material such as wood are allowed providing they are outside the minimum clearances detailed below.

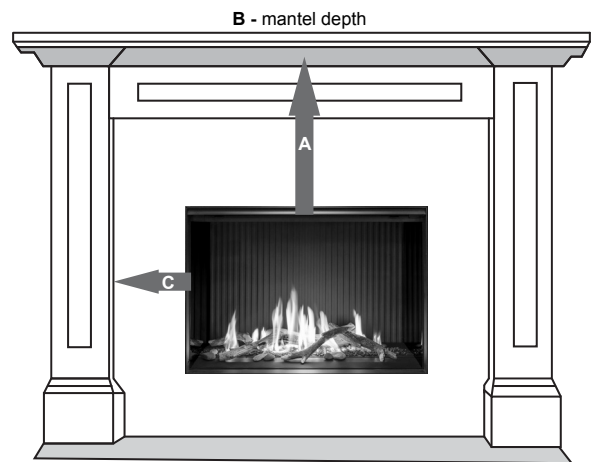
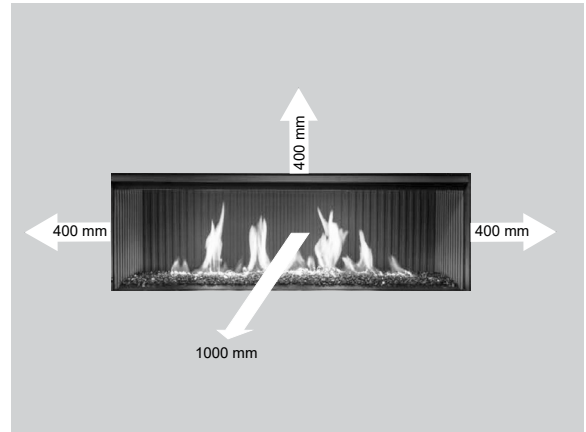

A	Mantel needs to be a minimum of 400 mm away from the edge of the glass
B	Maximum mantel depth at 400 mm (A) is 250 mm maximum
C	Surround needs to be a minimum of 400 mm away from the edge of the glass

For every 50 mm of added mantel depth there must be an additional 100 mm of clearance from the edge of the glass. For example:

Mantel depth A: clearance required

300 mm	500 mm
350 mm	600 mm
400 mm	700 mm

Hearths

Any hearth that is installed in the shaded area (shown below) must be capable of withstanding temperatures up to 100 °C. Some laminated materials may buckle or delaminate when exposed to high levels of heat.



1. A 3 mm air gap between the hearth and lower fire lip is critical. This allows for air flow to critical components and for correct operation of the IR receiver.
2. The lower support rail is only required if the side rails are used, side rails are required for combustible wall linings.
3. The finishing trim latches are not needed if a hearth is installed, they can be snapped off if they are in the way.

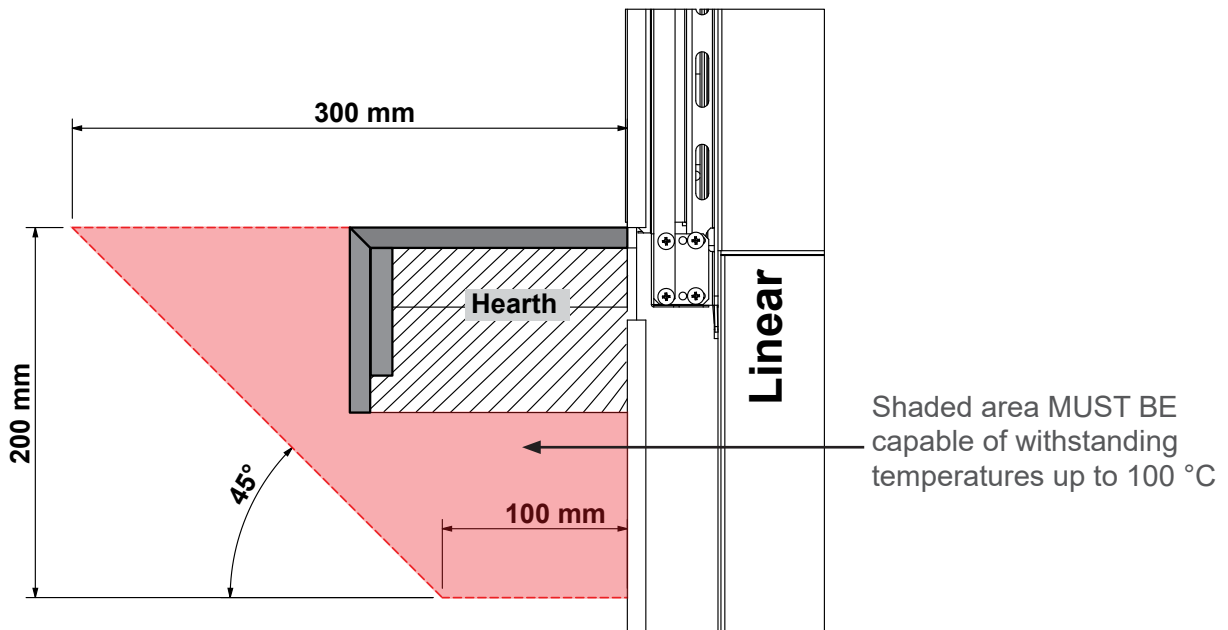

TV installation

The Linear has a fan that distributes warm air from the top of the appliance out into the room. As warm air is dispersed outwards and not directly upwards, installation of a TV may be an option.

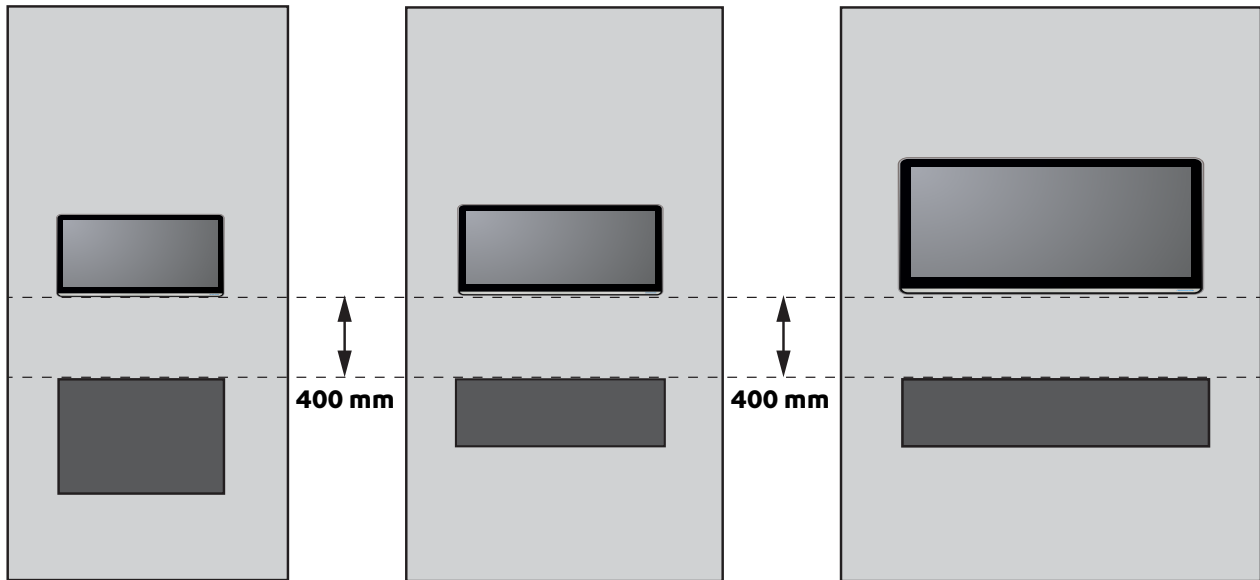

The diagram shows recommended clearances when installing a TV directly above the Linear, or into a recess. All dimensions are in millimetres.

Always check with the TV manufacturer

It is up to the owner to check the TV installation with the TV manufacturer—some have warranty conditions that state a TV is not to be installed above a fireplace.

Rinnai does not accept any responsibility for damage to a TV resulting from the use of this information.

Installation overview

1 Complete framing and base panel, p.12-15.

2 Prepare gas and electrical connections, and cavity ventilation for the room temp. sensor.

3 Fit the Linear

Move the Linear into the cavity. Tip forward slightly to get the two back feet in first. To reduce the weight you can remove the glass first (p.19). The Linear has adjustable feet on all corners. Use these feet to level the fire. This is critical so the wall lining can be installed flush to the lips of the fire. Once level, secure the Linear to the base of the enclosure using the four brackets, which also act as seismic restraints (p.18).

4 Complete the gas connection

To access the gas connection and gas control, remove the screws holding the Wi-Fi panel in place (refer image on p.28 for Wi-Fi assembly position). At this stage also check the flue configuration to see if a dip switch change is required. Check for gas leaks.

5 Fit the flue, refer separate flue installation guide.

6 Commission with the glass off

Follow the commissioning instructions, p. 20-24.

7 Install the burn media

Placement of the burn media is critical to the performance and safe operation of the appliance. Refer p.25 for more information.

8 Install the glass front

Reinstall the glass front, check operation of the fire, check the remote and Wi-Fi module is working (p.27).

9 Complete final framing and install the wall lining

Complete the final framing once you are satisfied the fire is working correctly—there will be limited access to the unit once final framing is completed.

Install the wall lining as one piece (so it doesn't crack), with a cutout for the glass, **up to** the lips of the unit. DO NOT go over the lips. There is an air gap of at least 3 mm around the lips of the fire, which is CRITICAL to safe operation, to ensure air flow in and around the unit.

Fix the wall lining in place. We recommend gluing as screws will transfer heat, and during installation there is the potential to damage some controls of the fire if screws are used, refer p. 28-35 for more information.

N.B: For new builds the final stage could be completed prior to commissioning.

Helpful tips

To level the unit and not affect where the feet go, the seismic brackets need to be elevated once the unit is off the pallet.

We STRONGLY recommend the gas is on to check the inlet pressure as access to controls after the wall lining is on is more difficult.

New build

Cavity ventilation for the room temperature sensor

Ventilation of an area of at least 2000 mm² is recommended in the cavity, ideally below the base of the fire. This is to provide room air to the temperature sensor located in the base of the fire, which senses the room temperature—refer image on p.16. Ventilation can be via a vent or an open toe kick at the base of the cavity.

Alternatively, provide a way of moving the room temperature sensor into the room, for example under the hearth—ensure it can be accessed/removed for service.

Cavity ventilation design ideas

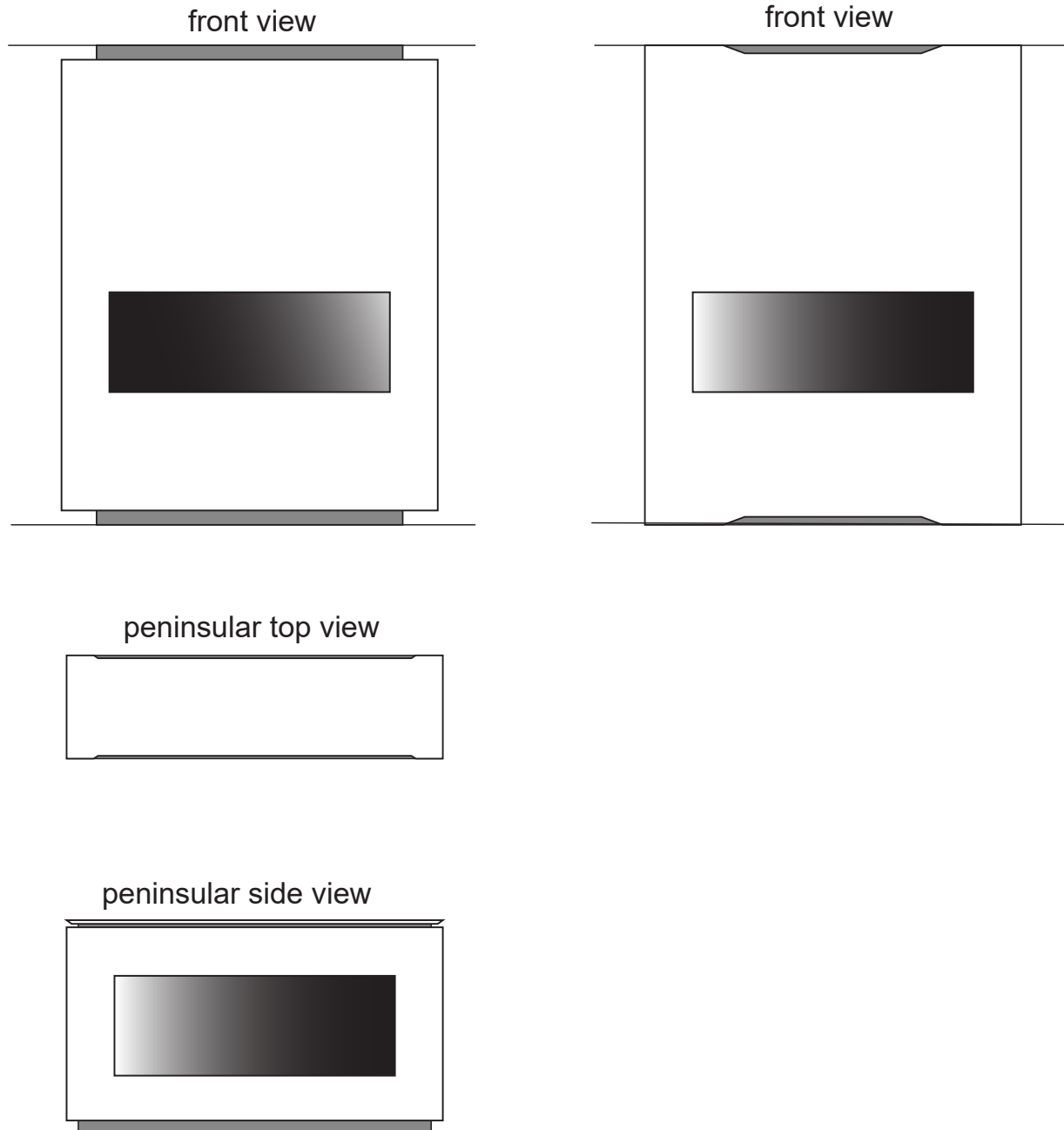

Framing dimensions



The framing dimensions have the studs offset. This is because the cavity needs to be framed based on the centreline of the Linear glass, **NOT** the opening size.

Where there is a requirement for a symmetrical installation, the cavity size will need to increase, refer following pages

Base board and connection cutouts

To ensure everything lines up and fits properly it's recommended that on the base the following dimensions are pencilled; glass centreline, unit depth centreline, feet position, gas and room thermistor cutouts.

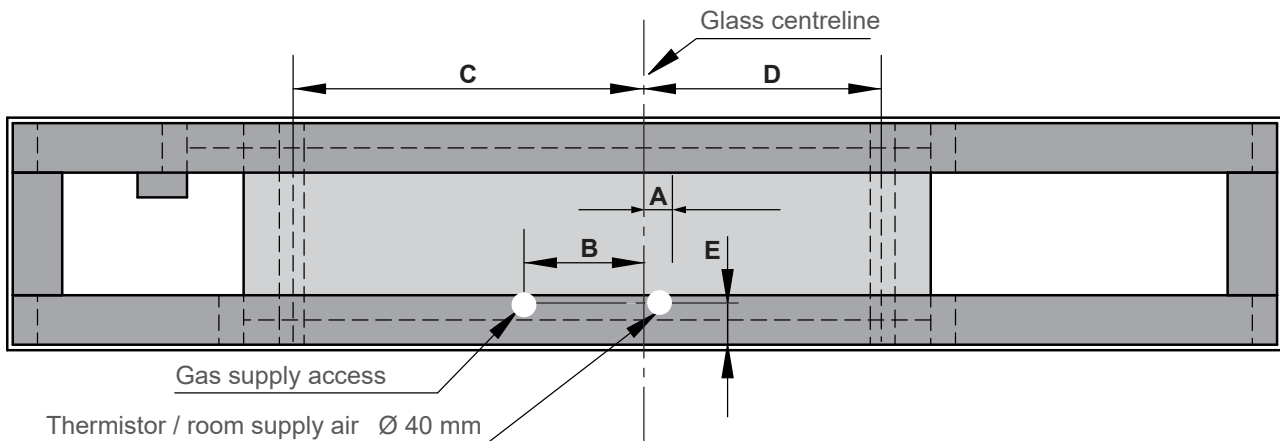
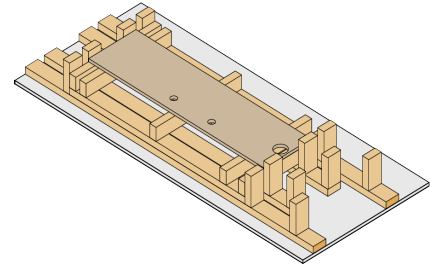

	Linear 800	Linear 1000	Linear 1500
A (room supply air)	50 mm	50 mm	255 mm
B (gas supply)	220 mm	220 mm	220 mm
C (support feet centres)	640 mm	740 mm	990 mm
D (support feet centres)	360 mm	460 mm	710 mm
E* (from front of cavity)	87 mm	87 mm	87 mm

* E assumes 10 mm wall board

Additional framing notes

- Wallboard is set 1 mm back from the front edge of the lips to allow for a slim edge plaster finish.
- To ensure the appliance performs correctly, without rattling, the Linear **MUST BE** installed on a flat level support base. The joists must be capable of supporting a minimum of 1.5 times the weight of the appliance—base panel is also designed to take the weight of the wallboard.

Important

Issues caused by rattling fires not installed on a flat level base, as detailed in this guide, will not be covered by warranty.

Linear 800 minimum framing dimensions (mm)



The framing dimensions have the studs offset. This is because the cavity needs to be **framed based on the centreline of the Linear glass, NOT the opening size**. Where there is a requirement for a symmetrical installation, the cavity size will need to increase, refer diagram below.

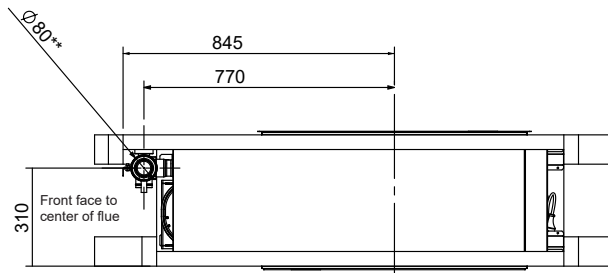

49 assumes 10 mm wallboard

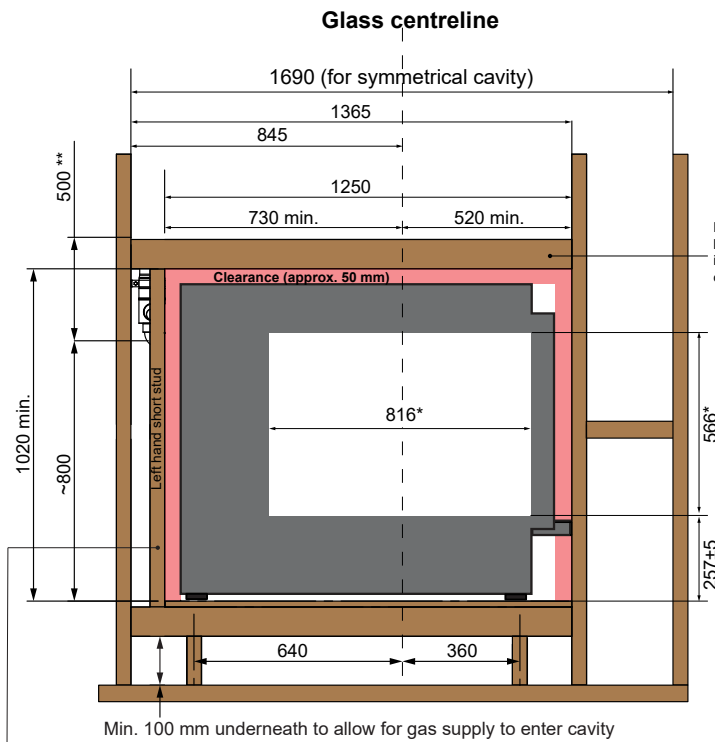
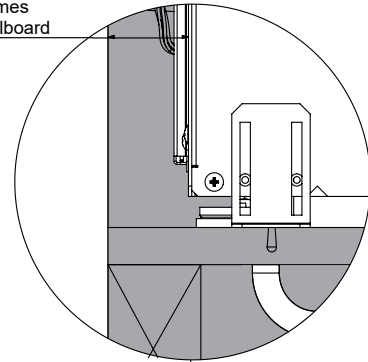

Recommend that the lintel is left until the fire is installed so clearances can be maintained

Shaded area is the required clearance area around the fire of approx. 50 mm. On the RHS this is automatically achieved with the carry bar.

IMPORTANT: Maintain the 50 mm clearance around the unit, even for non-combustible material. The RHS of the fire gets very hot and can transfer heat. Real-life example, a section of steel framing butted up to the RHS transferred heat to a plaster wall causing it to crack.

To give extra room the left hand short stud can be left out until the Linear is installed.

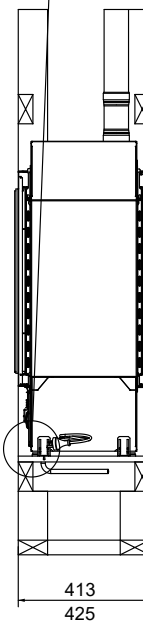

413 mm assumes a 10 mm wallboard on both sides of a double-sided unit.

425 mm is the min. for a single-sided unit with 10 mm wallboard to maintain 50 mm clearance to the back of the fire.

* Minimum wallboard cutout if using the outer finishing trim, refer table on p.28

** Maintain 25 mm clearance to combustibles for the first 500 mm of flue

- All dimensions are assuming a 10 mm wallboard
- Studs and joists are required directly below the support feet of the fire
- Framing shown is 90 x 45 mm
- Fire platform shown is 18 mm plywood

Linear 1000 minimum framing dimensions (mm)



The framing dimensions have the studs offset. This is because the cavity needs to be **framed based on the centreline of the Linear glass, NOT the opening size**. Where there is a requirement for a symmetrical installation, the cavity size will need to increase, refer diagram below.

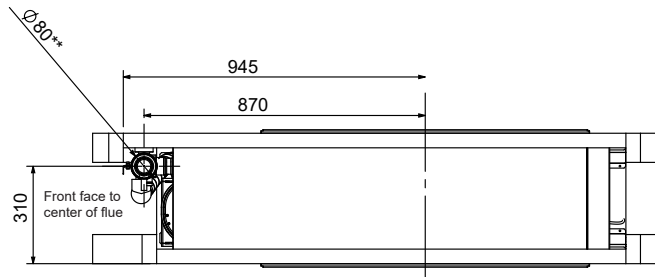

49 assumes 10 mm wallboard

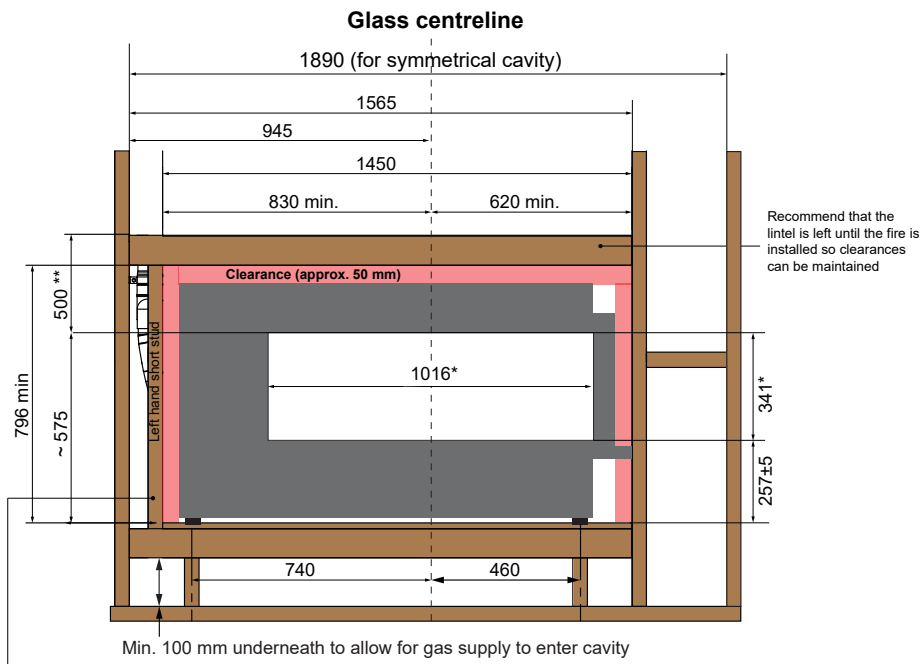
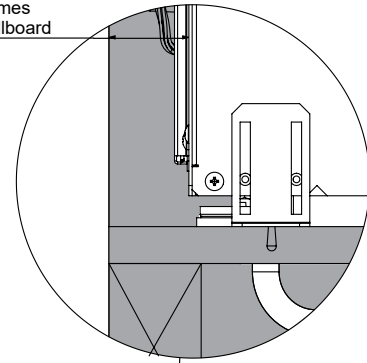

Shaded area is the required clearance area around the fire of approx. 50 mm. On the RHS this is automatically achieved with the carry bar.

IMPORTANT: Maintain the 50 mm clearance around the unit, even for non-combustible material. The RHS of the fire gets very hot and can transfer heat. Real-life example, a section of steel framing butted up to the RHS transferred heat to a plaster wall causing it to crack.

To give extra room the left hand short stud can be left out until the Linear is installed.

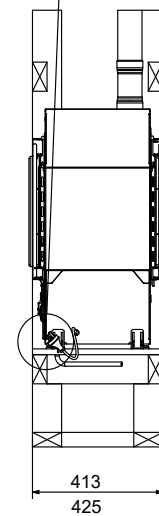

413 mm assumes a 10 mm wallboard on both sides of a double-sided unit.

425 mm is the min. for a single-sided unit with 10 mm wallboard to maintain 50 mm clearance to the back of the fire.

* Minimum wallboard cutout if using the outer finishing trim, refer table on p.28

** Maintain 25 mm clearance to combustibles for the first 500 mm of flue

- All dimensions are assuming a 10 mm wallboard
- Studs and joists are required directly below the support feet of the fire
- Framing shown is 90 x 45 mm
- Fire platform shown is 18 mm plywood

Linear 1500 minimum framing dimensions (mm)



The framing dimensions have the studs offset. This is because the cavity needs to be framed based on the **centreline of the Linear glass, NOT the opening size**. Where there is a requirement for a symmetrical installation, the cavity size will need to increase, refer diagram below.

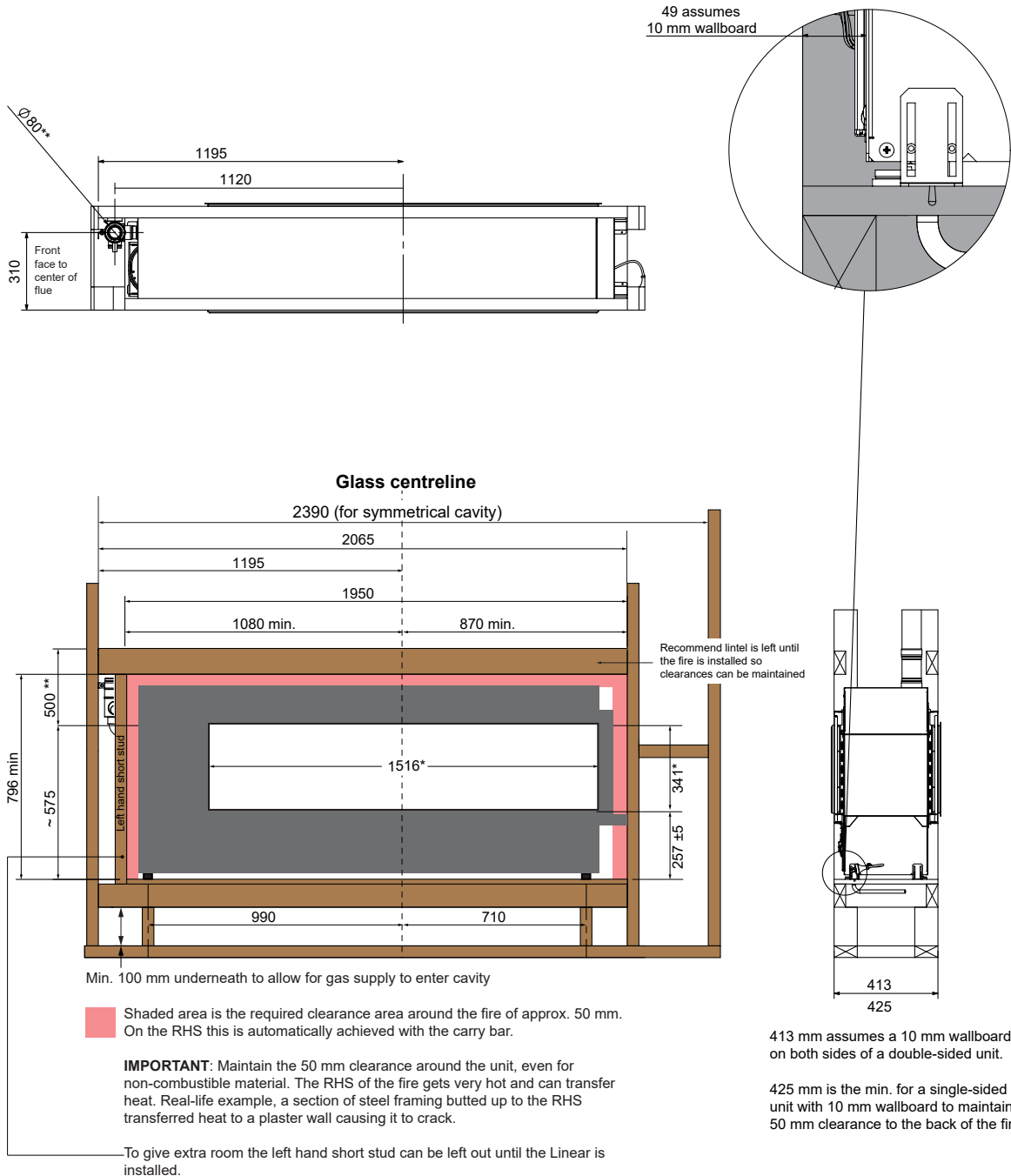

* Minimum wallboard cutout if using the outer finishing trim, refer table on p.28

** Maintain 25 mm clearance to combustibles for the first 500 mm of flue

- All dimensions are assuming a 10 mm wallboard
- Studs and joists are required directly below the support feet of the fire
- Framing shown is 90 x 45 mm
- Fire platform shown is 18 mm plywood

Gas supply

Gas pipe sizing must consider the gas input to this appliance, as well as other gas appliances in the building. The gas supply termination is inside the heater, and enters from the lower left hand side of the appliance.

Once the gas connection is completed and checked for gas leaks lock the sliding plate in place to stop the connection rattling, refer image below.

Purging the gas supply

Foreign materials and debris such as swarf, filings etc. must be purged from the gas supply. Failure to do so may cause damage to the control valve causing it to malfunction.

The use of rubber hose for any gas connection to a fixed appliance is NOT authorised by the manufacturer.

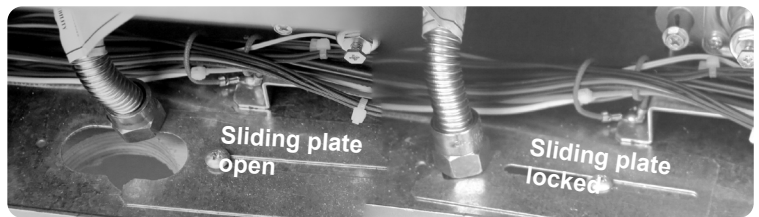
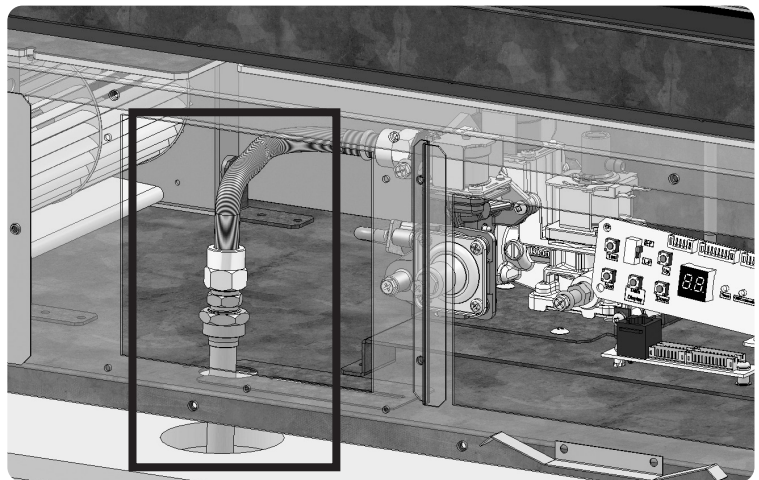

Room temperature sensor

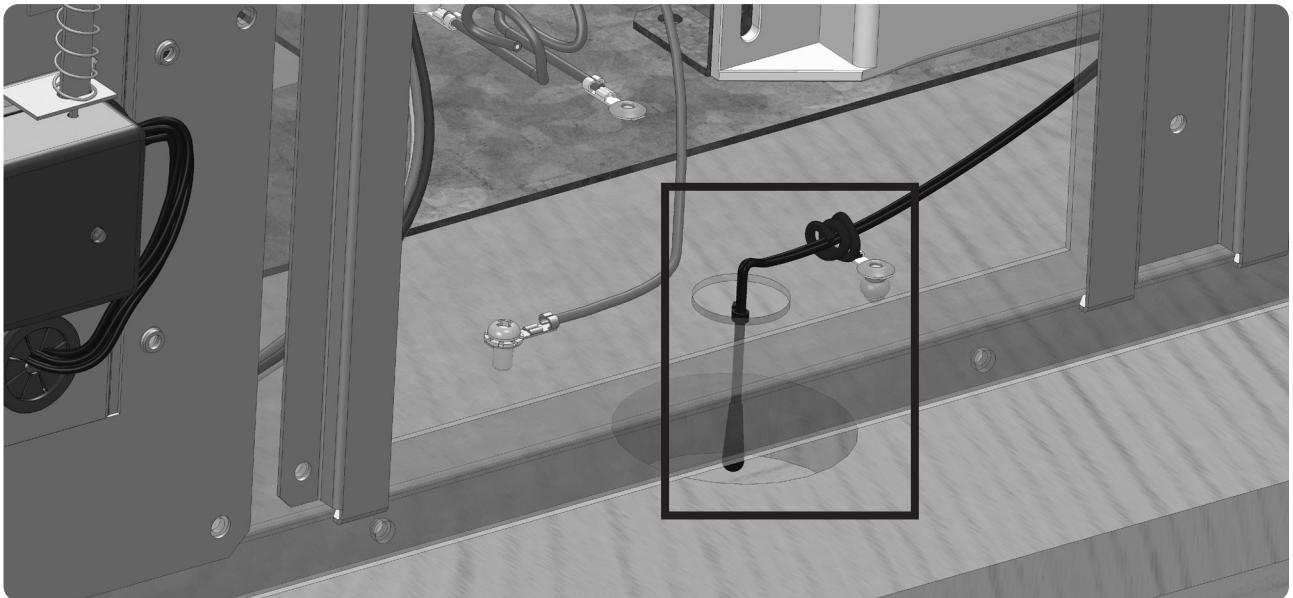

Once installed the room temperature sensor (supplied on a 1 m cable) should be set so the bulb on the end is outside of the fire box and in an area where room air will be drawn over it, refer image above. Make sure it will still be accessible for service when the wall linings have been installed.

Electrical supply

This fire has a 1.5 m power cord with a three pin plug supplied. The power cord passes through a slot in the front right hand side of the appliance, approximately 150 mm from the front of the unit.

The fire needs be plugged into a 230 V, 10 A earthed power point. The power point must not be above the fire. Alternatively the appliance can be direct wired if the power supply is to be concealed. Consult a qualified electrician if direct wiring is required as it must comply with AS/NZS 5601.1 and AS/NZS 3000.

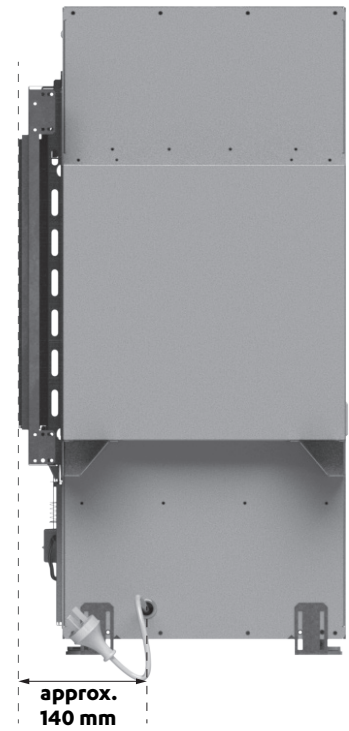

Flue terminal position

The below diagram highlights the position of the flue terminal in relation to the glass centreline.

	Linear 800	Linear 1000	Linear 1500
A	655 mm	755 mm	1005 mm
B	800 mm	575 mm	575 mm

Installing the Linear into the cavity

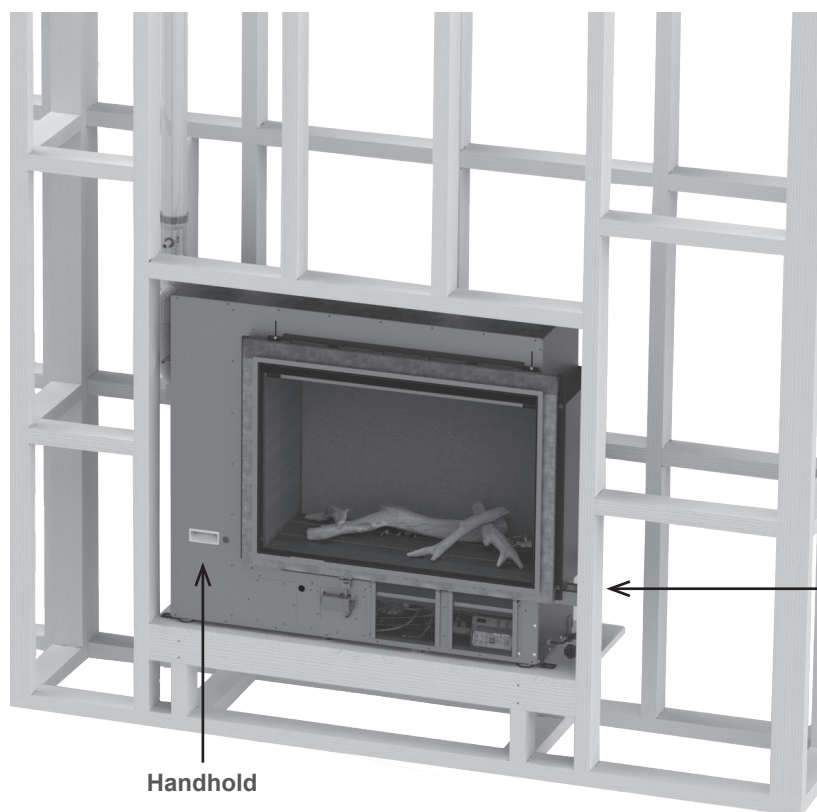

Important

Remove the two white handholds as they can vibrate and cause rattling issues. There are stickers on the side of the appliance that state 'Discard handle after installation'.

Using the handholds (white slots LHS and carry bars RHS), carefully lift and slide the Linear into the enclosure and position in place.

Adjustable feet and seismic brackets

Use the feet on all corners of the unit to adjust the fire so that it is level. The feet are adjustable. Having the unit level is critical to the installation, so the wall lining can be installed flush with the lips of the appliance.

Once level secure the Linear to the bottom of the cavity using the four seismic brackets¹.

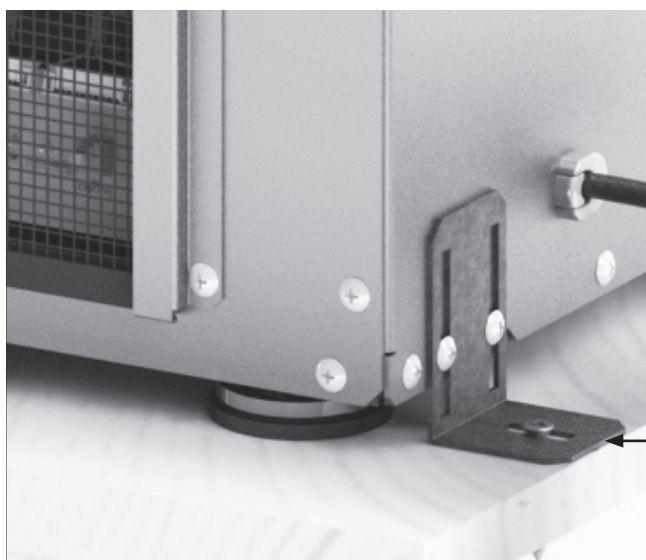

To level the unit and not affect where the feet go, the seismic brackets need to be elevated before the unit is installed into the cavity

¹ The Linear 800, due to its height, also has two top support seismic brackets. Fitting of the brackets is done once the framing has been installed with the correct wall lining offset. Refer separate 'Top support bracket installation' instructions (13375).

Removing the glass front

The glass front sits in a narrow channel at the bottom of the fire and is held in place by glass retainer latches positioned at the top and either side of the unit. The 1500 model has an extra glass retainer latch in the center.

To remove the glass:

1. The louvre, as shown below, holds the glass in place. To remove tilt and rotate the bottom edge out, and remove—put the louvre to one side.
2. Push the top glass retainer latches up and slightly to one side to release the top section of the glass.
3. Using the frame tabs at the top of the glass front, lift up and gently slide to the right. Rotate the glass until the left section comes free, then move the glass front to the left to remove the right section.



Will stay in the upright position if moved slightly to one side

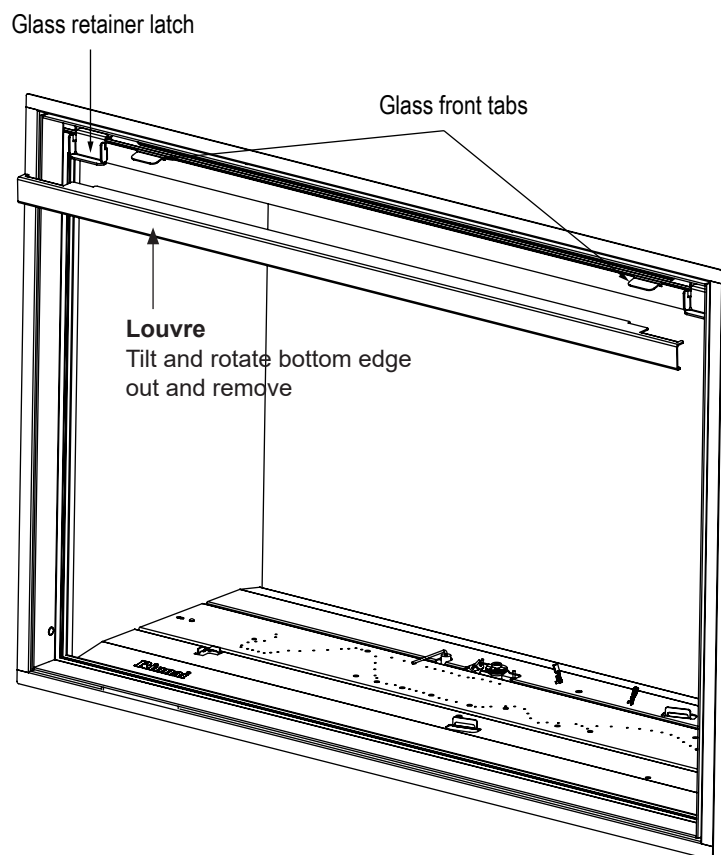
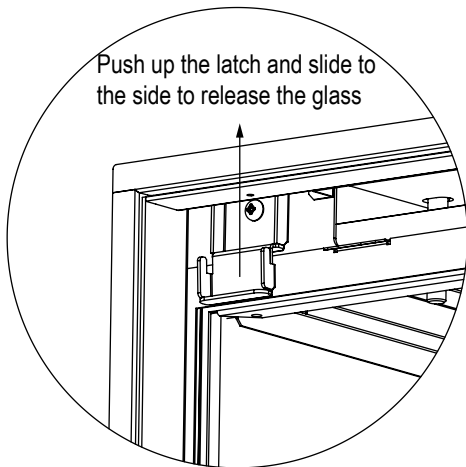

Commissioning

Accessing the commissioning instructions, installed in the bottom of the unit, will not normally occur during installation, which is why the instructions are detailed in this guide.

For servicing and maintenance the commissioning sheet is installed in a pouch inside the base panel of the appliance:

- 1500 right hand side of the gas control
- 800/1000 tucked in behind the Wi-Fi

The Linear comes with the high and low operating pressures factory preset. Under normal circumstances the operating pressures do not require adjustment during installation. Make adjustments **ONLY** if the unit is not operating correctly and all other possible causes for incorrect operation have been eliminated.

In all instances the inlet supply pressure to the appliance **MUST BE** checked and set within the operating parameters of the appliance. If the appliance cannot be adjusted to perform correctly call 0800 746 624.



240 V, risk of electrical shock

Before attempting to remove any panels ensure the fire is isolated from the mains supply. **DO NOT** leave the appliance unattended when the power is connected and the panels are removed.

Commissioning requires the plastic buttons on the PCB are pushed. We do not recommend using a screwdriver as breakage can occur, a blunt item or finger is best.

The gas pressures of the Linear are factory set for **long flue (L-F)** installations. All other installations, less than 3 m in length, as pictured below, are short flue (S-F) installations and will require a dip switch change.

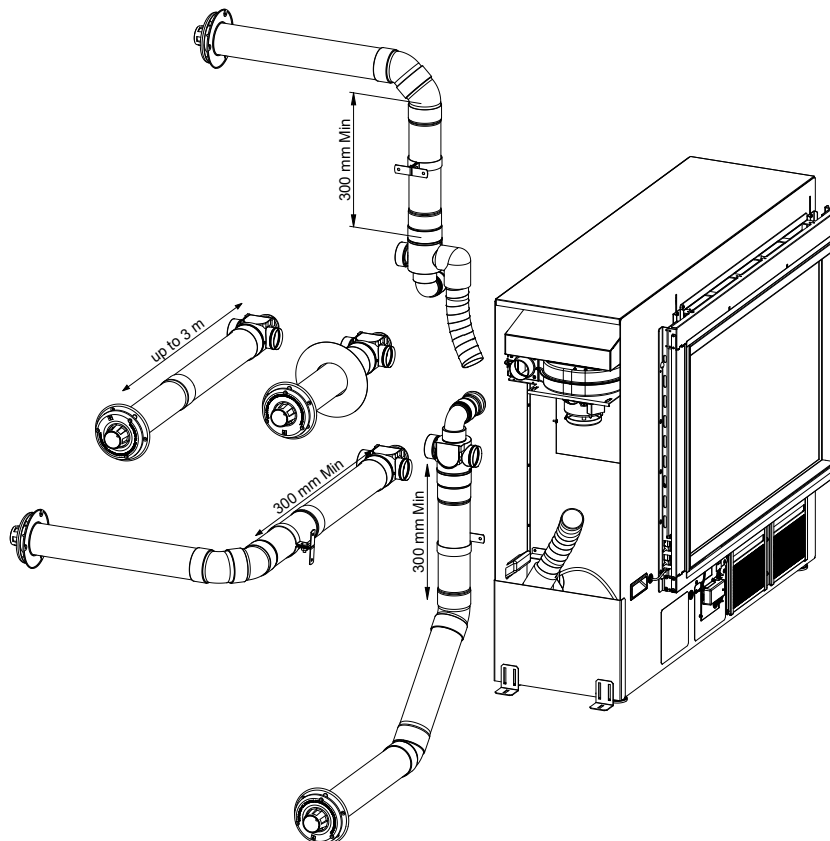



Commissioning and setting the gas pressures for the Linear is done with the glass off and before the burn media is added. The exception is the 800/1000 FlameTech. The burners and the two FlameTech logs need to be temporarily positioned on the aeration sleeves for commissioning.

The pressures can be checked by operating the buttons on the control panel PCB through the front access panels on the Linear before the wall lining has been installed, or by pulling out the control panel PCB and accessing the buttons through the opening from the front of the appliance (as shown).

Check the pressures against those printed on the data plate of the appliance. If the data plate is not easily accessible the pressures are also detailed on the next page. If no adjustment is required during some stages of the gas pressure setting process, the 'SET' button will still need to be pushed to go to the next setting.

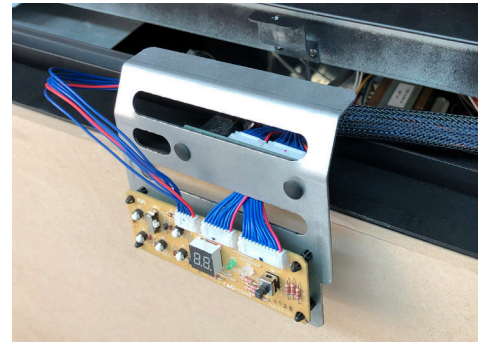

Commissioning the PCB

Steps required to commission the PCB—ONLY done if the PCB is being replaced or after a gas conversion

1. Turn on the gas and power supply.
2. Press the 'Test' button, the display will show the gas code. Press the 'Up' and 'Down' buttons to obtain the gas code for the unit, and press 'Set' to lock in the code.
A1 = NG
L1 = LPG

The gas pressures can now be checked.

Room thermistor offset

The Linear PCB has an additional LED display, a room thermistor offset. This will display after the gas code and will be factory preset to 0 (range 0 ± 5)¹. It will only need adjustment if there is significant variation in the thermistor reading and the actual temperature reading of the room.

Linear control panel PCB with the dip switch set to L-F (long flue)

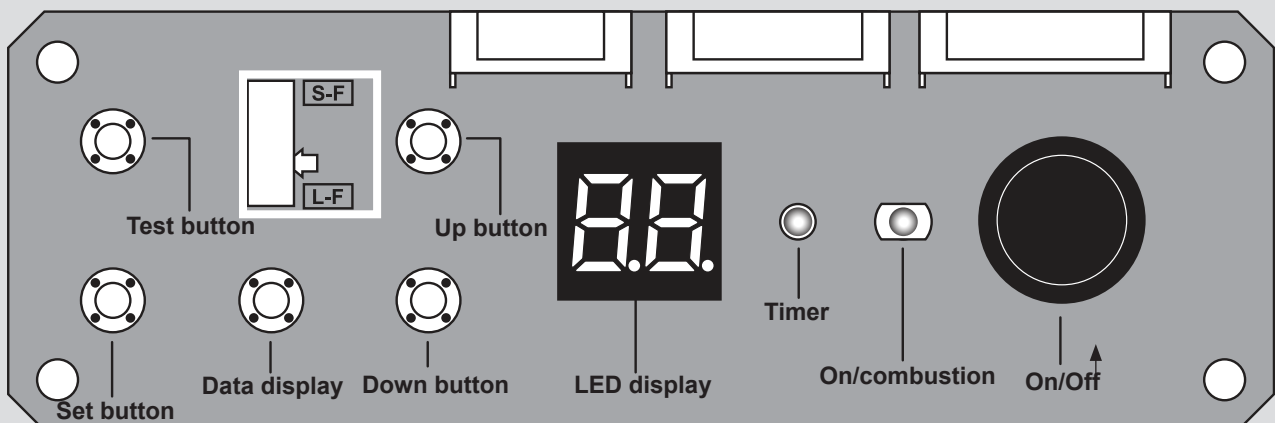

Note: When working the ON/OFF button needs to be OFF otherwise the On/Off button on the appliance won't work.

¹ 0 ± 5 °C in 15 stages, each stage (up/down button press) represents a third of a degree change, e.g. six 'Up' presses (stages) equates to a 2° offset.

Linear 800 and 1000 gas control

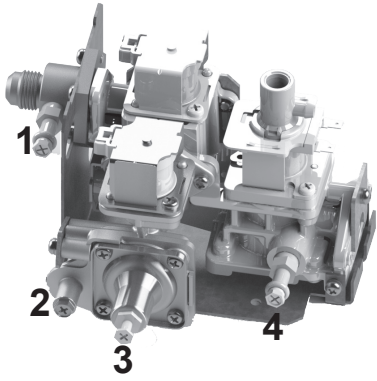

Linear 1500 gas control (with the extra solenoid)

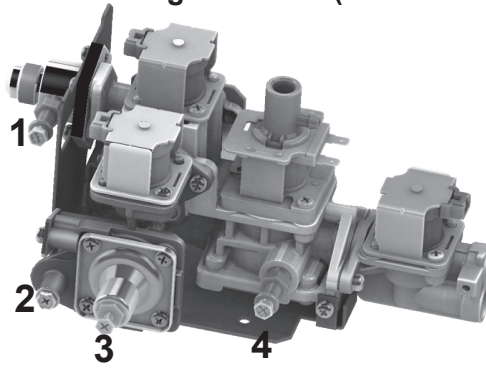

1	Inlet pressure test point screw
2	Pilot pressure test point screw
3	Pilot pressure adjustment screw (manometer position)
4	Main burner pressure test point screw

Check the pressures against those printed on the data plate. If the data plate is not easily accessible use the figures in the tables below.

RHFE800SF RHFE800DF RHFE1000SF RHFE1000DF	NG		ULPG	
	Gas rate Hi SF/LF MJ/hr	35	32	31
Gas rate Lo MJ/hr	15		14	
LH RH injector Ø mm	2.0		1.20	
Aeration sleeve LH RH mm	4.5 x 1		9 x 2	
Pilot kPa	0.98		2.0	
PL kPa	0.20		0.35	
PH SF/LF kPa	0.95	0.79	1.95	1.65

RHFE1500S RHFE1500D	NG		ULPG	
	Gas rate Hi SF/LF MJ/hr	40	37	37
Gas rate Lo MJ/hr	14		14	
Main injector Ø mm	2.3		1.4	
LH RH injector Ø mm	1.6		0.95	
Aeration sleeve centre mm	22.5		N/A	
Aeration sleeve LH RH mm	21		17	
Pilot kPa	0.98		2.0	
PL kPa	0.3		0.74	
PF kPa	0.87		1.90	
PA kPa	0.59		0.95	
PH SF/LF kPa	0.80	0.67	1.70	1.38

RHFE1000S RHFE1000D	NG		ULPG	
	Gas rate Hi SF/LF MJ/hr	34	31	32
Gas rate Lo MJ/hr	15		14	
Main injector Ø mm	2.8		1.70	
Aeration sleeve centre mm	22		N/A	
Pilot kPa	0.98		2.0	
PL kPa	0.19		0.40	
PH SF/LF kPa	0.80	0.65	1.85	1.57

Gas pressure setting

PL	= main burner on low
PF	= main burner on high
PA	= all burners on low
PH	= all burners on high

Sequence will vary slightly depending on the model:

Linear 800, 1000: PL > PH

Linear 1500: PL > PF > PA > PH

Checking the supply pressure

1. Remove the inlet test point screw and connect the manometer hose.
2. Press the heater On/Off button to start the ignition sequence, ensuring the correct inlet pressure is available with all other gas appliances operating on high.
3. Press the heater On/Off button to stop the heater operation.
4. Disconnect the manometer hose and replace the inlet test point screw.

Before commencing with the setting of the burner pressures the correct flue length must be set. The appliance is factory set for long flue installations (refer image on p.20), with the dip switch set to L-F (long flue). For a short flue installation, set the dip switch to S-F (short flue).

Setting the pilot pressure

1. Remove the pilot test point screw and connect the manometer hose.
2. Press the heater On/Off button to start the ignition sequence, ensuring the correct inlet pressure is available with all other gas appliances operating on high.
3. Press the test button twice, the heater will light to main burner on its lowest setting (stage 1) and the display will show PL.
4. Adjust the pilot pressure as required by manually adjusting the pilot pressure adjustment screw. Press the On/Off button to stop the heater operation.
5. Disconnect the manometer hose and replace the pilot test point screw.

Setting the operating pressure

1. Remove the main burner test point screw and connect the positive manometer hose.
2. Press the heater On/Off button to start the heater.
3. Press the test button twice, the heater will light to the main burner on its lowest setting (stage 1) and the digital display will show PL.
4. Press the up or down buttons to set the pressure for the appropriate gas type. Press the set button once to save the setting.

1500 only

5. The display will now show PF (main burner stage 3). Press the up or down buttons to set the pressure for the appropriate gas type. Press the set button once to save the setting.
6. The display will show PA (main burner stage 4). Press the up and down buttons to set the pressure for the appropriate gas type. Press the set button once to save the setting. It can take several seconds for the solenoid to open and the pressure to stabilise.
7. The display will show PH (main burner stage 7). Press the up or down buttons to set the differential for the appropriate gas type. Press the set button once to save the setting.
8. The display will show 7 and two dashes (800, 1000) or 7 and six dashes (1500), if not, then there is a commissioning error—repeat steps.
9. Press the on/off button to stop the unit.



Remove the manometer hose and replace the gas control test point screw. Commissioning is now complete.

Please note: After the gas code is displayed the LED will show \square . This is the room thermistor offset that is preset to \square (range $0\pm 5\text{ }^{\circ}\text{C}$)¹. This is typically only adjusted in troubleshooting scenarios, and is not part of commissioning.

¹ $0\pm 5\text{ }^{\circ}\text{C}$ in 15 stages, each stage (up/down button press) represents a third of a degree change, e.g. six 'Up' presses (stages) equates to a 2° offset.

Linear collection wiring diagram

Mark	Part
B	Burner
BL	Combustion Fan Motor
ER	Electrode
F	Fuse Electrical
FM	Convection Fan Motor
FR1-2	Flame Rod 1-2
L	LED Panel
LC	LED Controller
OH.TH 1-2	Over Heat Thermistor 1-2
PB	Pilot Burner
POV	Modulated Solenoid Valve
R.TH	Room Thermistor
RCR	Remote Control Circuit
SC	Speed control
SP	Sparker
SV1-4	Main Solenoid Valve 1-4
TF	Thermal Fuse
TR	Transformer

Mark	Colour
bk	black
bl	blue
gr/y	yellow-Green stripe
gy	grey
or	orange
pl	purple
r	red
w	white
y	yellow
p	pink
br	brown

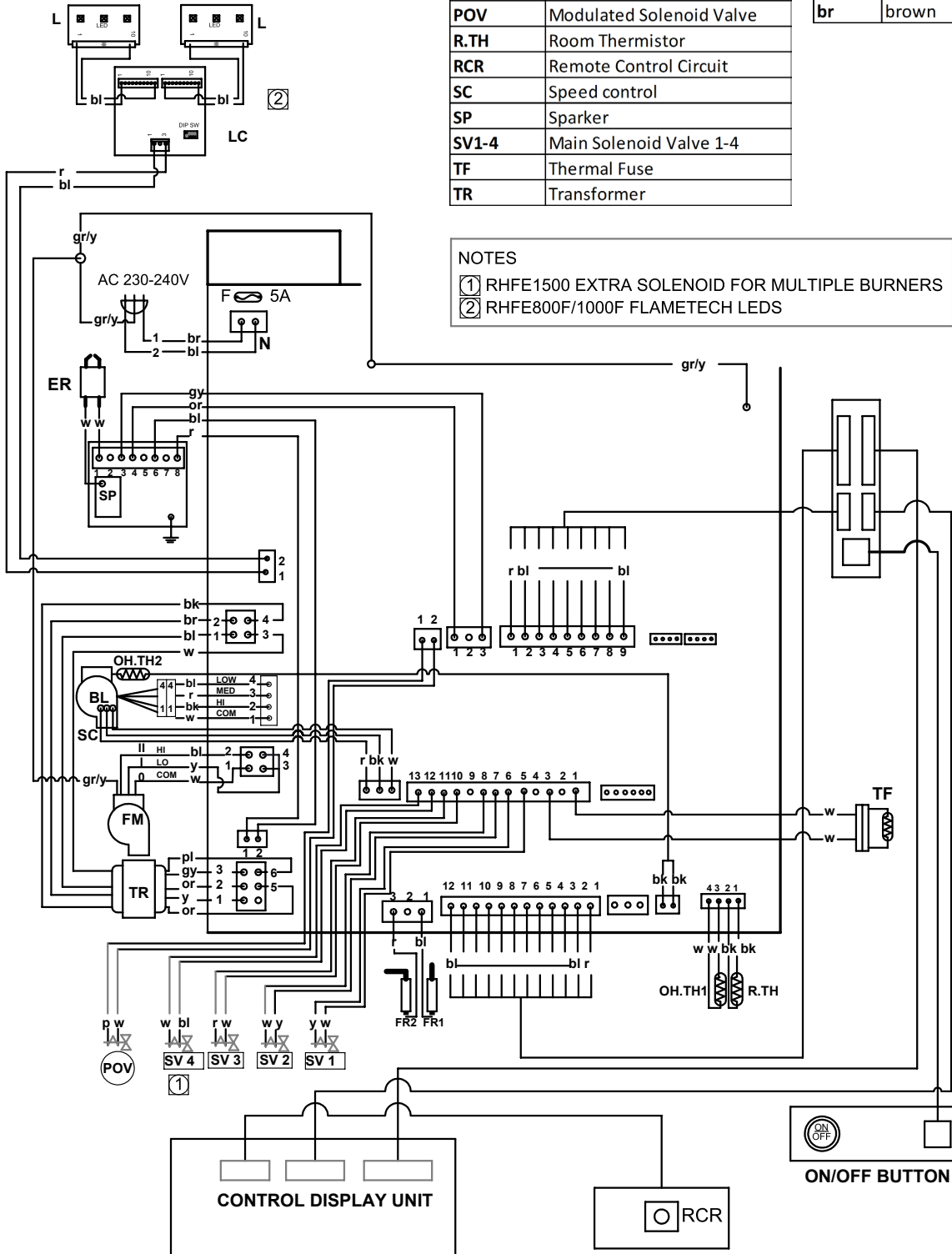

Burn media installation

Experience has shown that the majority of performance problems are caused by burn media being installed incorrectly. Please take the time to read and follow the instructions as malfunctioning due to incorrect burn media placement is not covered by warranty.

We also have 4-7 minute burn media installation videos on the Rinnai NZ YouTube channel, refer links in the below table.

- The Linear MUST NEVER be used with other burn media or burn media that is damaged.
- The Linear burn media sets are different and cannot be interchanged, please ensure you have ordered the correct set before installation

Model	YouTube link
Linear 800 FlameTech log set	https://www.youtube.com/watch?v=hGaMsnQSnlw&t=6s
Linear 1000 FlameTech log set	https://www.youtube.com/watch?v=gKCvMvA7XF4
Linear 1000 traditional log set	https://www.youtube.com/watch?v=Q8L9dD5STd4&t=3s
Linear 1000/1500 crushed glass	https://www.youtube.com/watch?v=E70qe9nt4rl&t=2s
Linear 1500 traditional log set	https://www.youtube.com/watch?v=T69_iP0Q1lc&t=7s

Separate burn media installation instructions

For the safe operation of the fire, placement of the burn media is a critical step in the installation process. Due to the number of steps involved, separate instructions (too many pages to incorporate into this guide) have been developed. There is also a colour burn media placement sheet attached to the glass frame. Make sure you have these before starting.

Correct placement

It is important to place the burn media in the correct position. Incorrect placement can create carbon build-up and affect performance. Malfunctioning due to improper placement is not covered by warranty.

Test operation and lighting sequence

It may take approximately two hours of operation for the burn media to achieve their full flame pattern and glow. During the initial burning-in period, some smoke and smell may be experienced. The appliance should run on a high setting in a well ventilated room until these dissipate. It is important to check the flame pattern during this time.

Abnormal flame pattern

Abnormal flame performance and/or pattern can indicate a problem with the fire, such as blocked gas injectors, flame rod obstruction, or that the burn media has shifted. Some warning signs that could indicate a problem:

- Unusual smell from the fire
- Continued difficulty or delay in establishing a flame
- Flame appears very short or very long
- Flame only burns part way across the burner
- Severe soot building up on the inside of the glass door

Linear 1000 Flametech log set

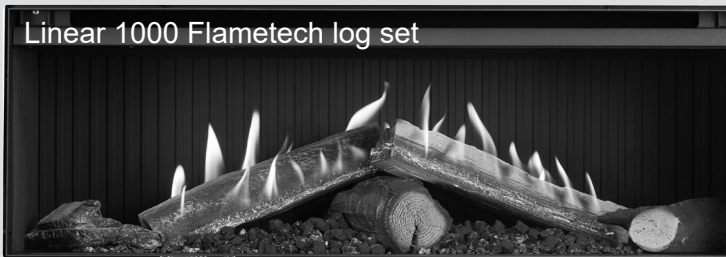

Linear 800 Flametech log set



Linear 1000 log set



Linear 1000 modern media (glass)

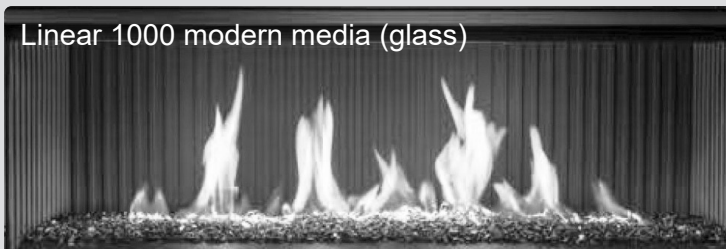

Linear 1500 log set



Important

It is the responsibility of the installer to check that under normal conditions of the appliance, all flue gases are exhausted to the outside atmosphere, and that there is no spillage of combustion gases into the room.

If the appliance cannot be made to perform correctly please contact Rinnai.

Linear 1500 crushed glass is not shown, the flame pattern will be the same as the 1000 model shown.

Check the Wi-Fi connection

When the power is on the Wi-Fi LED should flash and then turn a solid red to indicate everything is ready for setup via a smart device. Go through the app sequence with the homeowner, if they are available, as part of the installation process is testing the Wi-Fi connectivity and correct operation of the fire with the homeowner. The Wi-Fi app is available on:

- Google Play > search Rinnai fire app
- Apple app store > search Rinnai fire app

Summary of how the app works

1. Wi-Fi module in the fire, once installed and has power connected, is on.
2. Homeowner downloads the Rinnai Wi-Fi app on their smart device.
3. Through the app, the Wi-Fi in the fire links (pairs) to the homeowners smart device.
4. Homeowner, through the app setup process, then links the Wi-Fi in the fire to the Wi-Fi router in the home—this essentially makes the smart device the fireplace controller.

If unable to connect, the Wi-Fi board must be reset by pressing down on the metal tab above the Wi-Fi assembly on the unit. The image below highlights where the Wi-Fi assembly is positioned. If this doesn't work switch the power off and then back on again to reset the fire—try a couple of times if it doesn't work the first time.

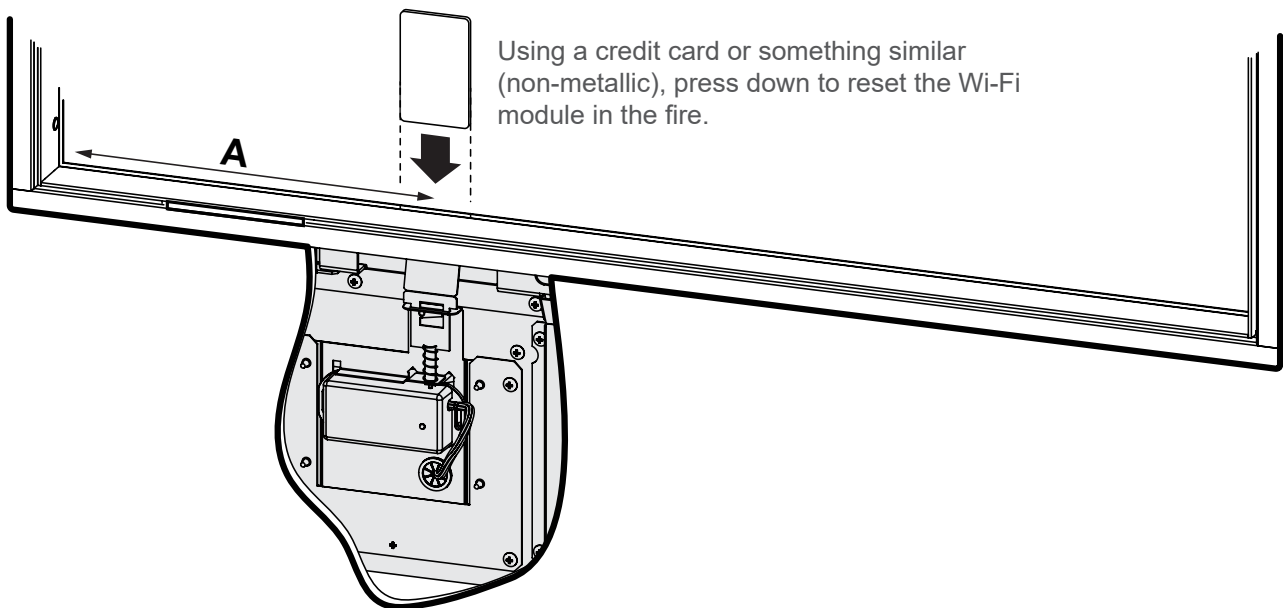

Approximate position of the Wi-Fi module from the left hand side of the fire—where the On/Off button is.

Wi-Fi reset position - A	
800	265 mm
1000	350 mm
1500	650 mm

Installing the wall lining



An air gap of at least 3 mm around the fire is critical to the safe operation of the Linear to ensure air flow in and around the unit.

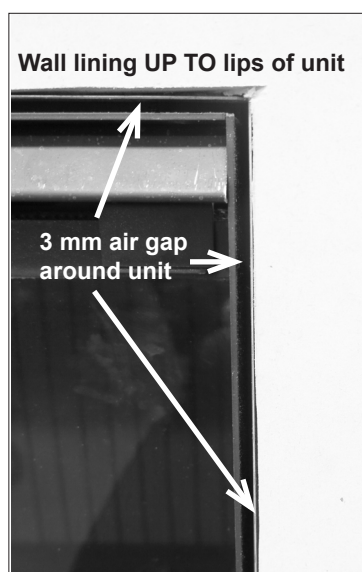
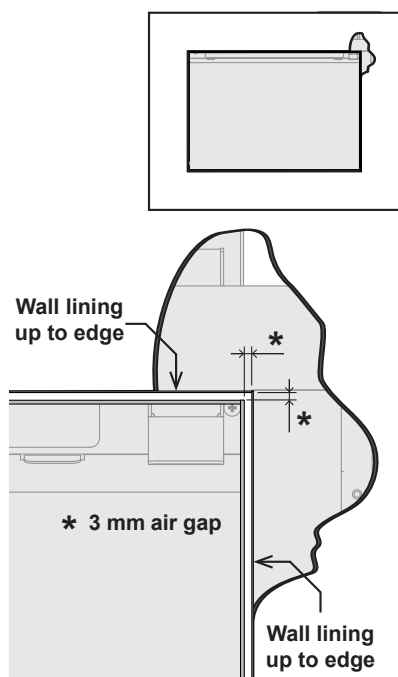

Important

Avoid getting plaster in the air gap around the fire lips

Additional notes

While the fire is safe when installed with combustible wall linings in accordance with these instructions, please be aware that the wall will go through hot and cold cycles and can reach temperatures of up to 80 °C. This could impact the durability of timber or wallpaper finishes.

The wallboard support rails are used as a fixing point for the wall lining, it is recommended that screws are not used as a permanent fixing along the top edge of the fire—use a suitable adhesive instead.



If screws are used (maximum length 25 mm) around the edge, ensure they do not interfere with the working parts of the fire (latches, IR receiver, On/Off button).

Cutout reference		800	1000	1500
A	Minimum	816 x 566	1016 x 341	1516 x 341
	Maximum	830 x 580	1030 x 355	1530 x 355
B		816 x 566	1016 x 341	1516 x 341
C		810 x 560	1010 x 335	1510 x 335

Please note: A, B, and C relate to the drawings on pages 31-35.

IR receiver lens

Do not be tempted to paint over the clear plastic IR receiver lens that peeps through in the bottom left of the fire. This will severely restrict the distance at which the simple remote will operate.

There have been instances where marble slabs, corten steel, and other structures have been installed in front of the fire blocking the ability to operate the fire with the remote or app. If the design cannot be altered a nano device needs to be considered.

Below is an image to highlight the position and names of the different linear framing components. Adapt as necessary, depending on the wall lining being installed.

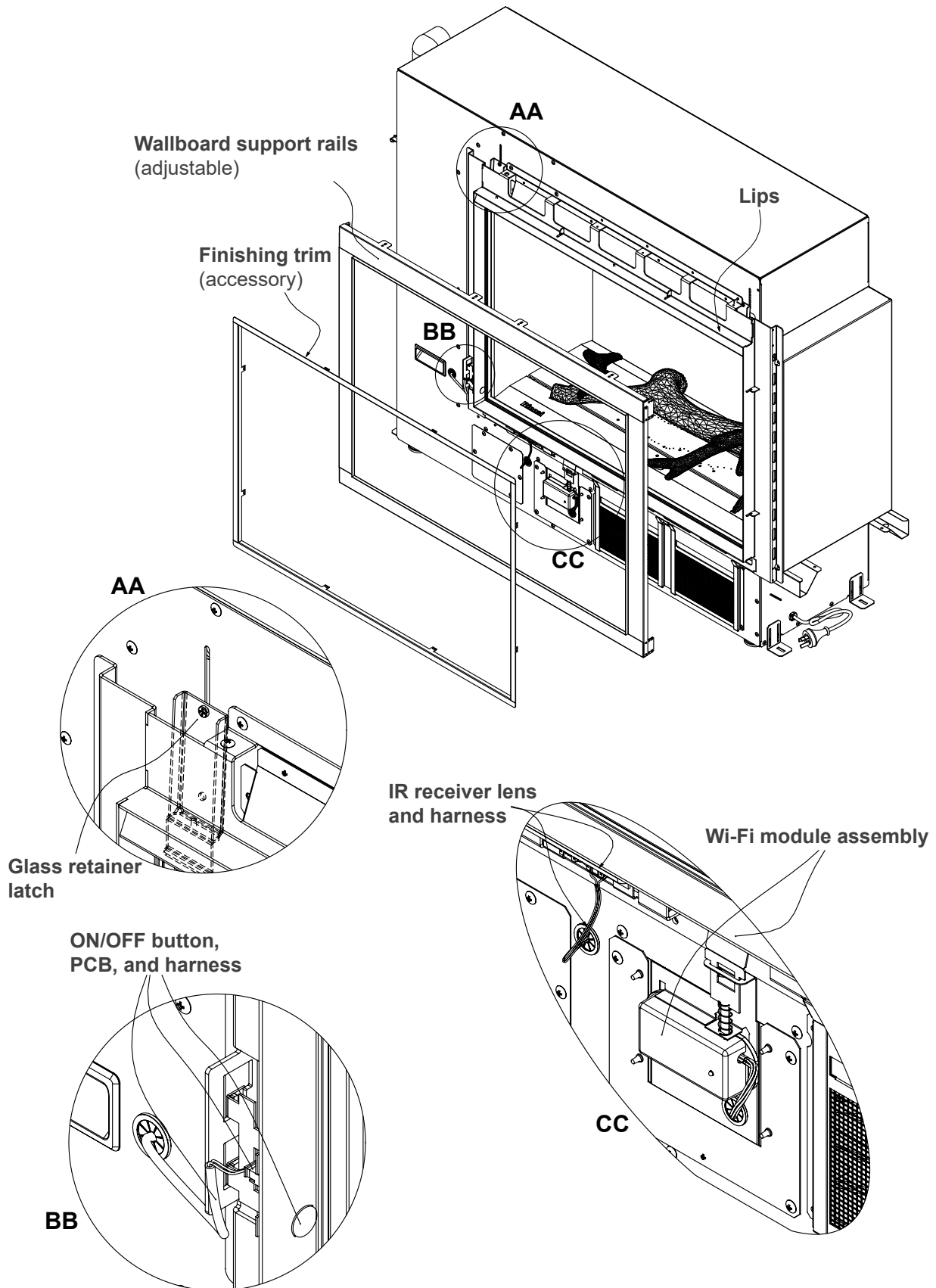

End view detail showing non-combustible zones (any wall set forward of the fire)

Adapt as necessary depending on whether a single or double-sided model. Diagram below shows a double-sided model.

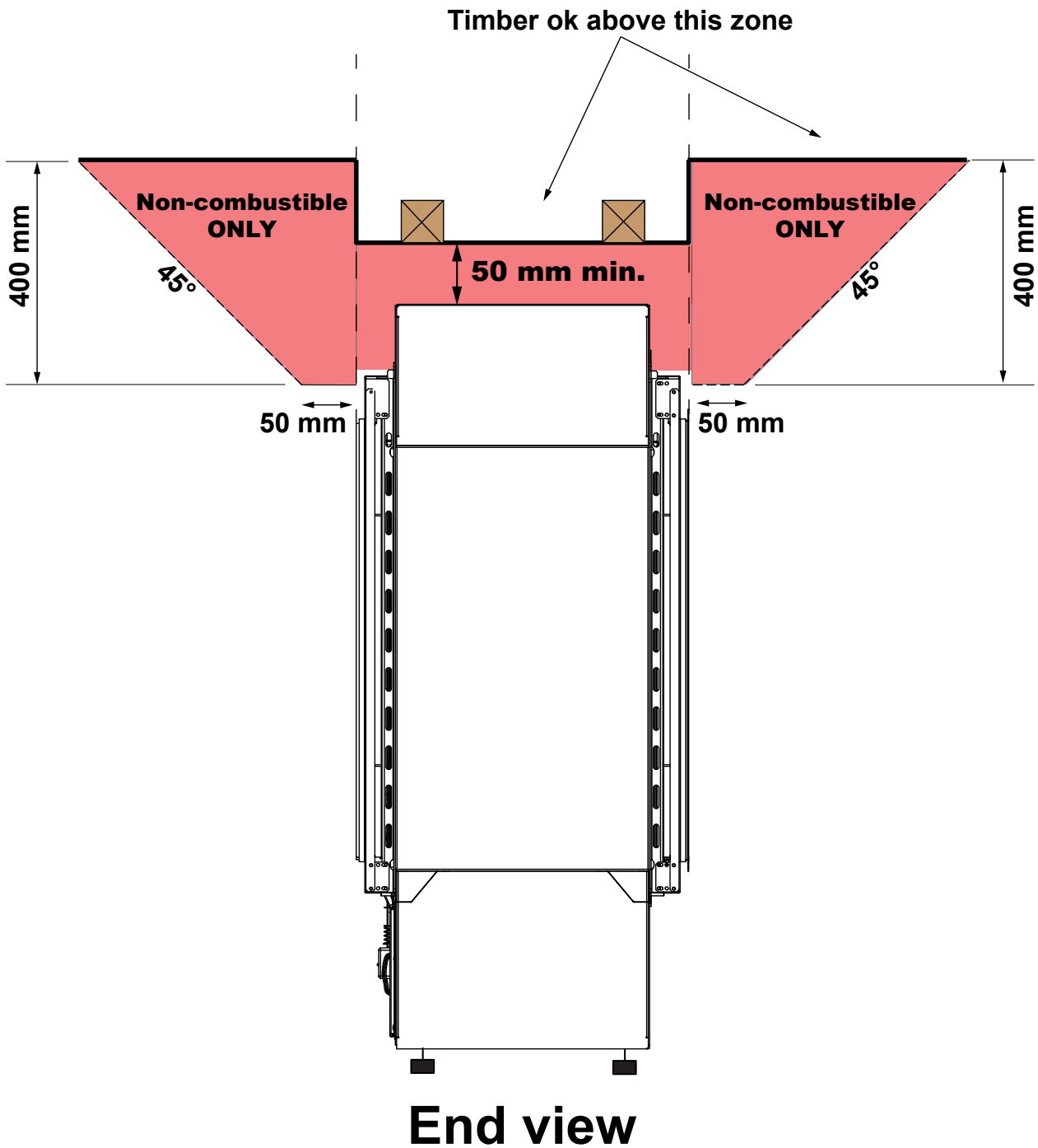

Plasterboard wall with plastered finish (wall flush with front of fire only)

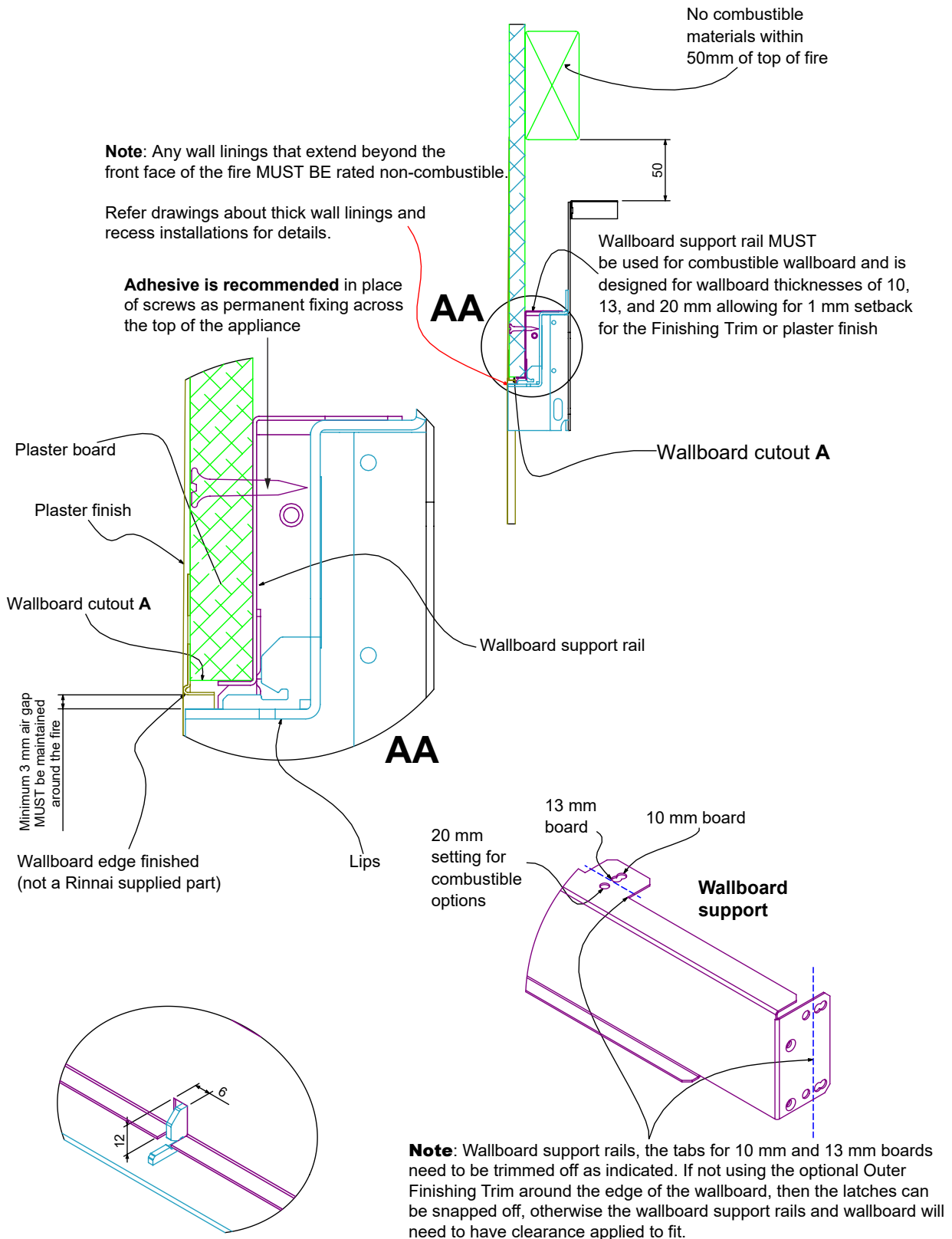

Edge finishing options

(applicable to any installation method)

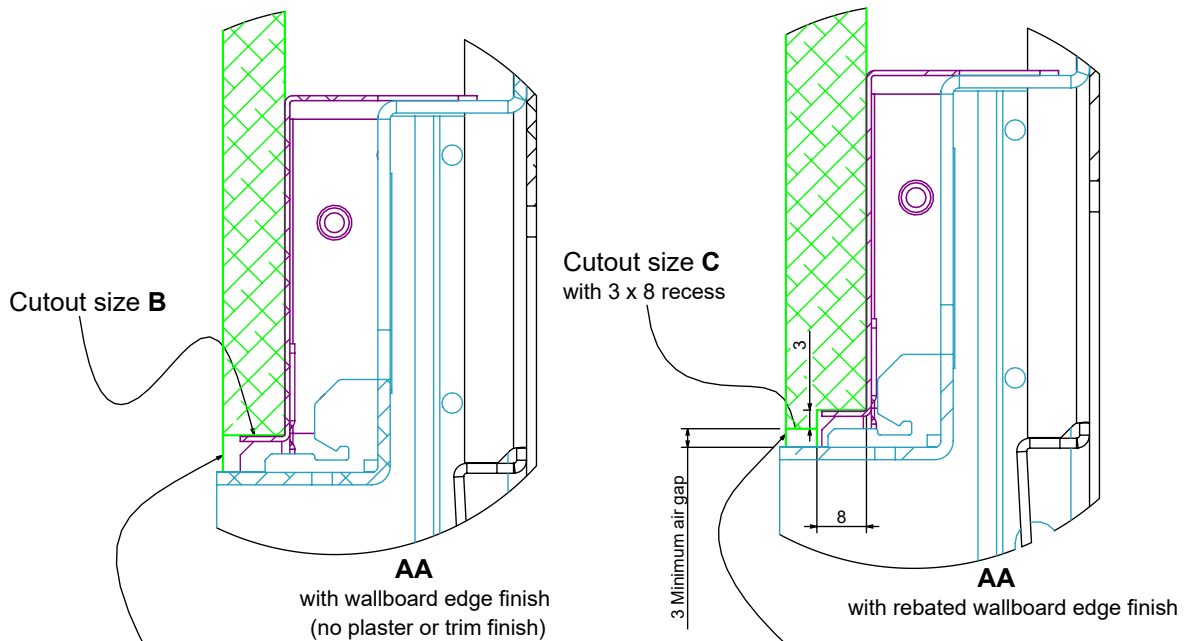
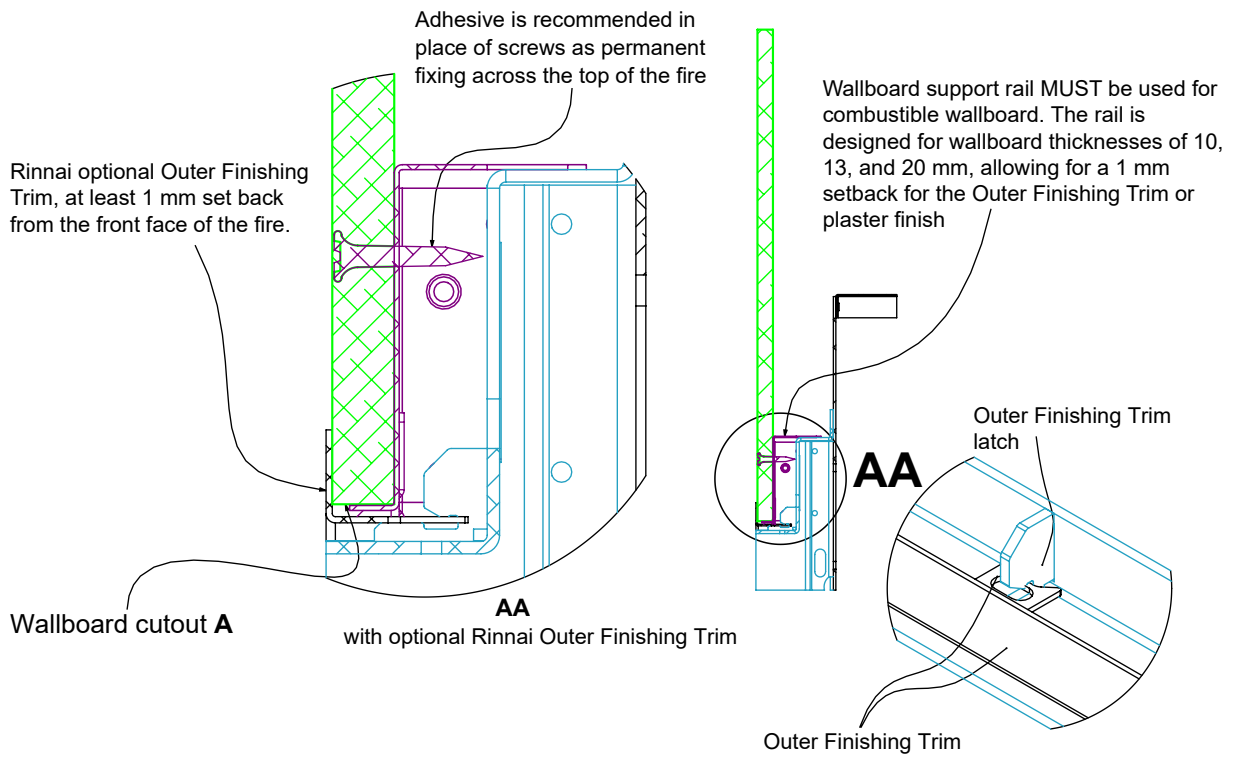

With this bigger gap there is a risk that the wallboard support panel and the Outer Finishing Trim clips will be visible. Consider this before using this method.

This method will produce a closer fit to the fire but does make the front edge vulnerable to damage

Tiled or second skin wall linings (combustible and non-combustible options)

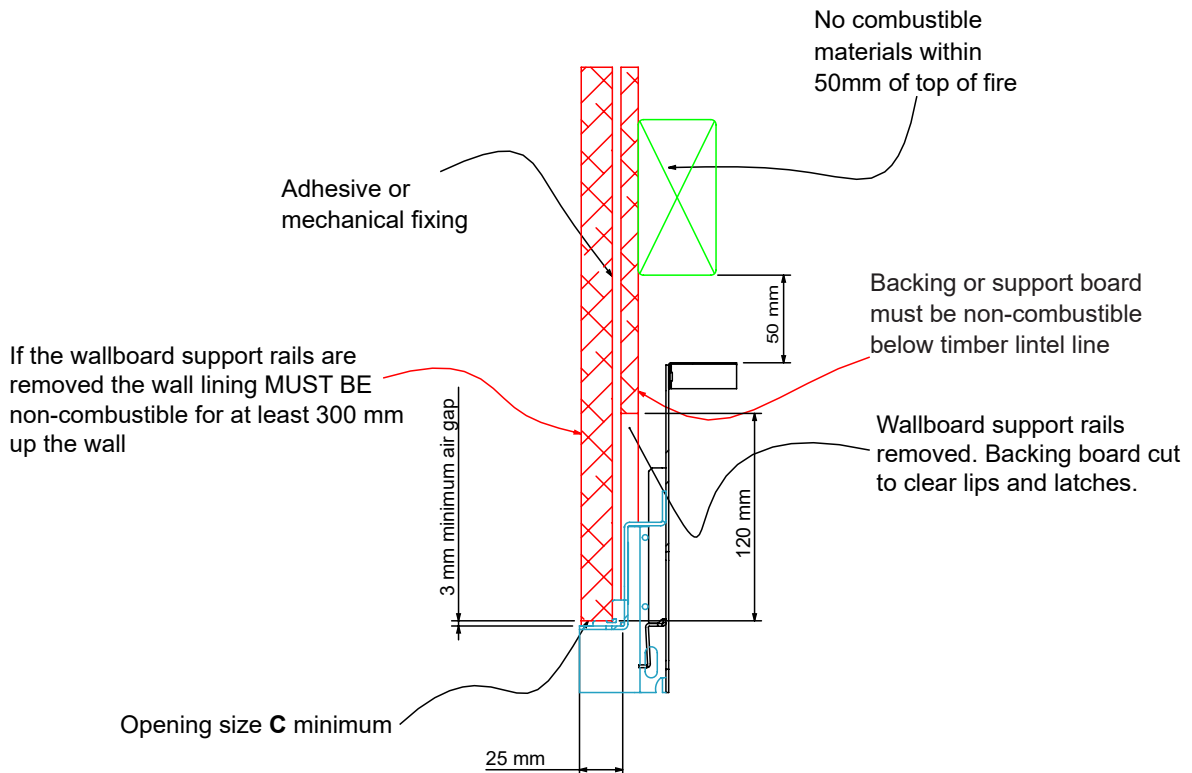
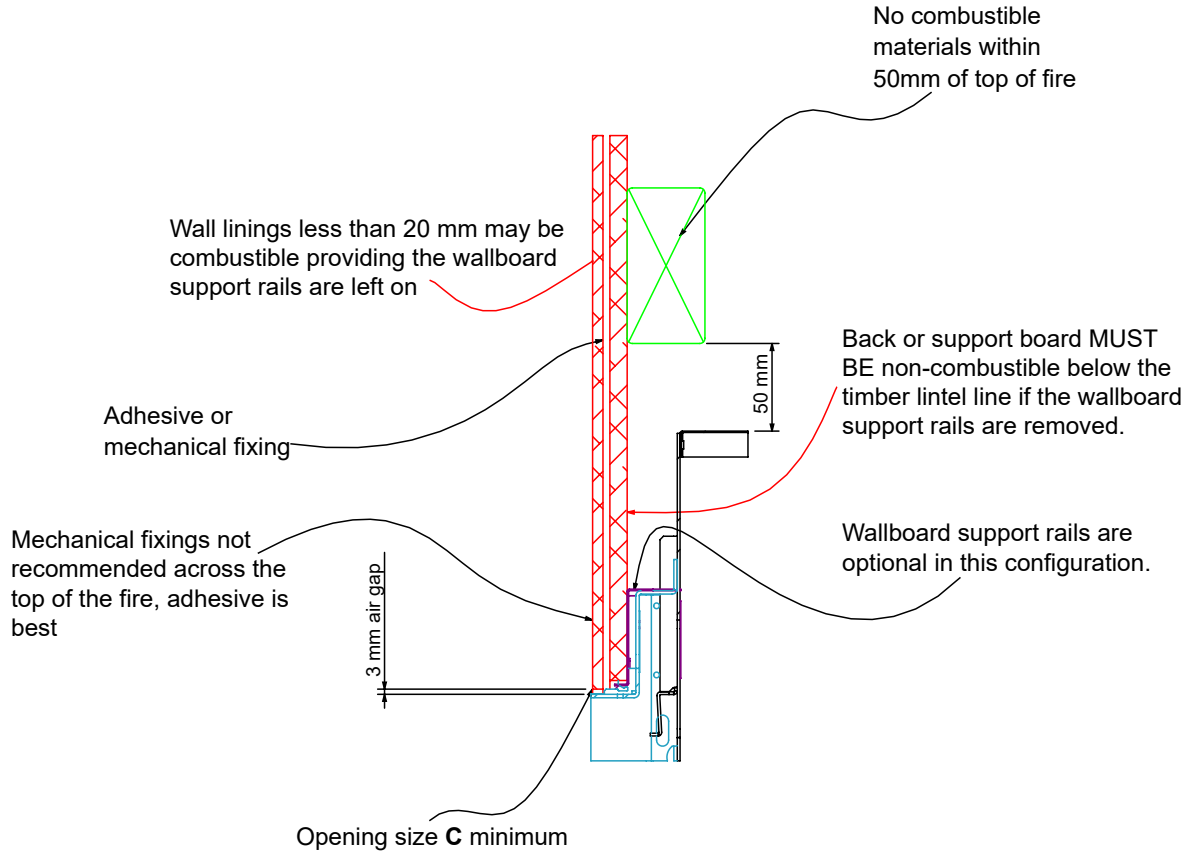

Non-combustible thick wall linings

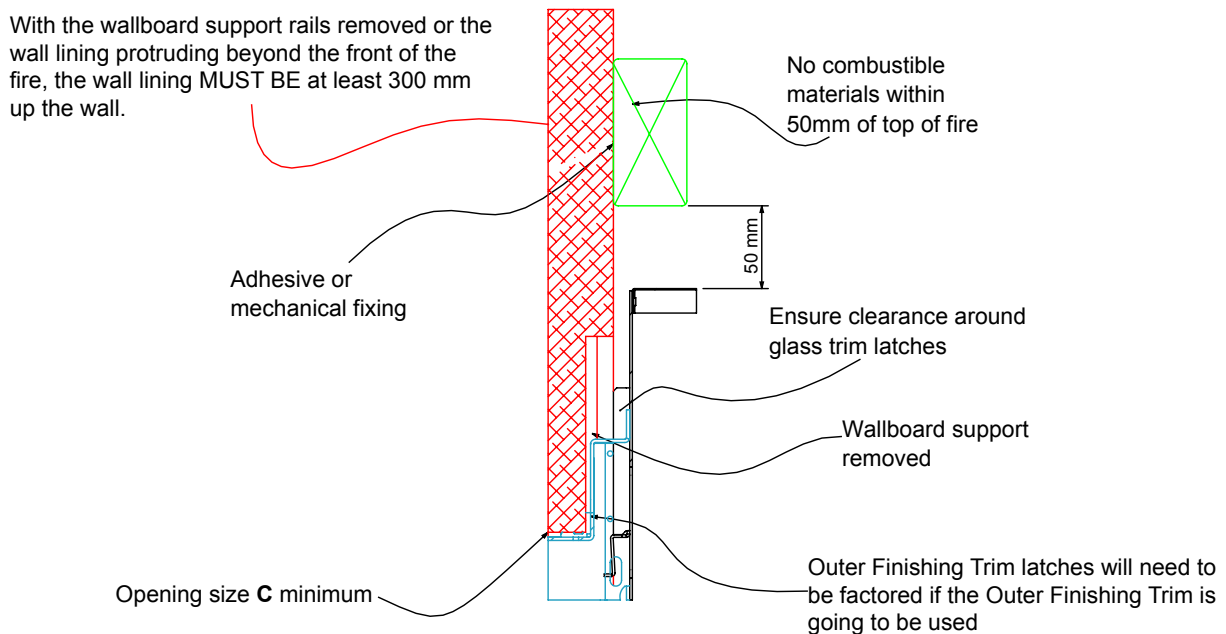
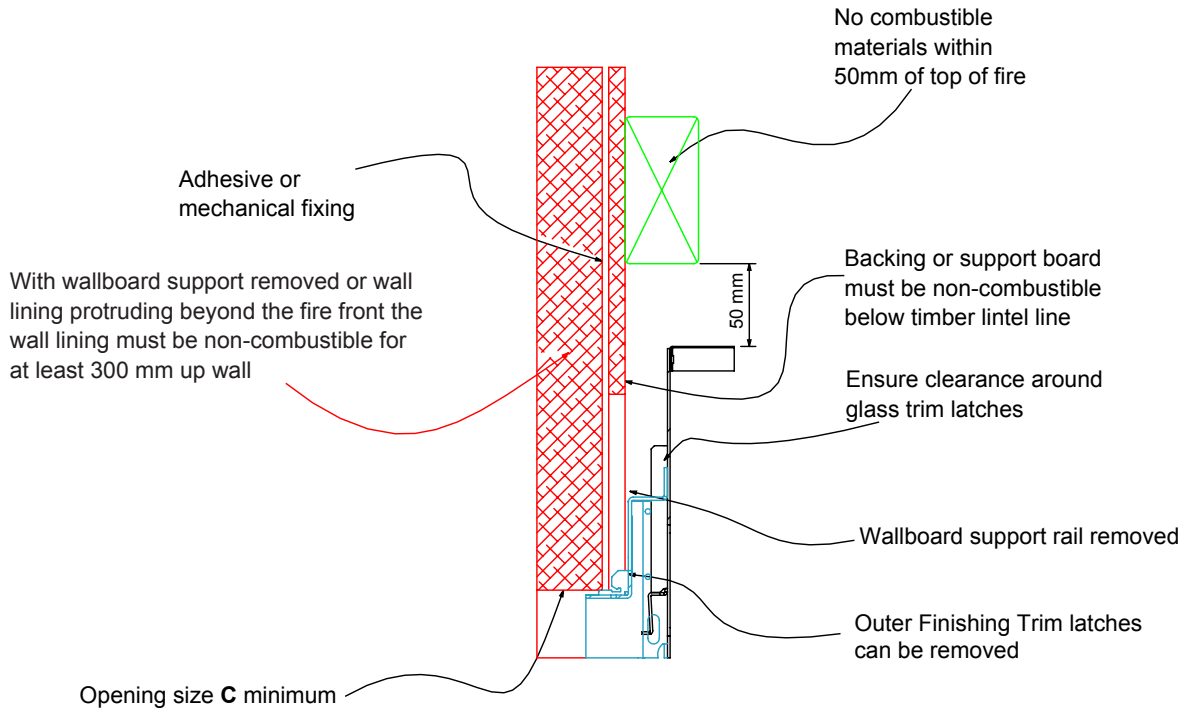

Non-combustible recess installations

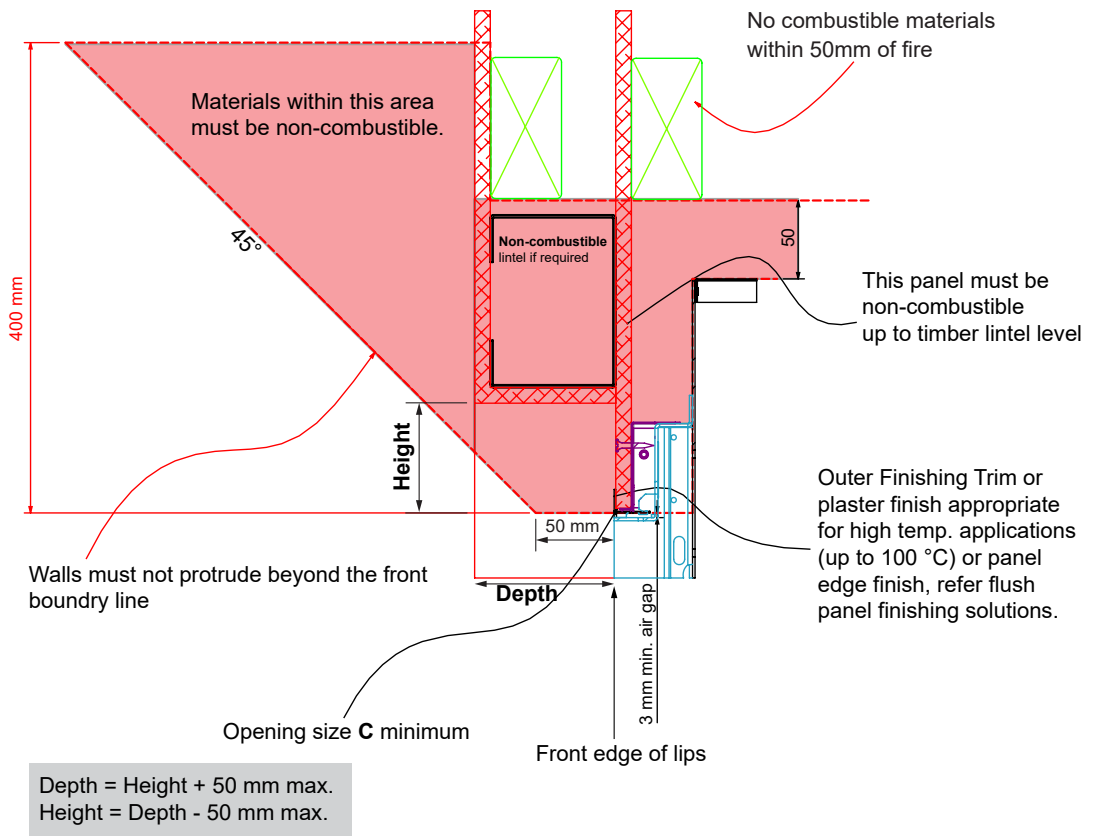
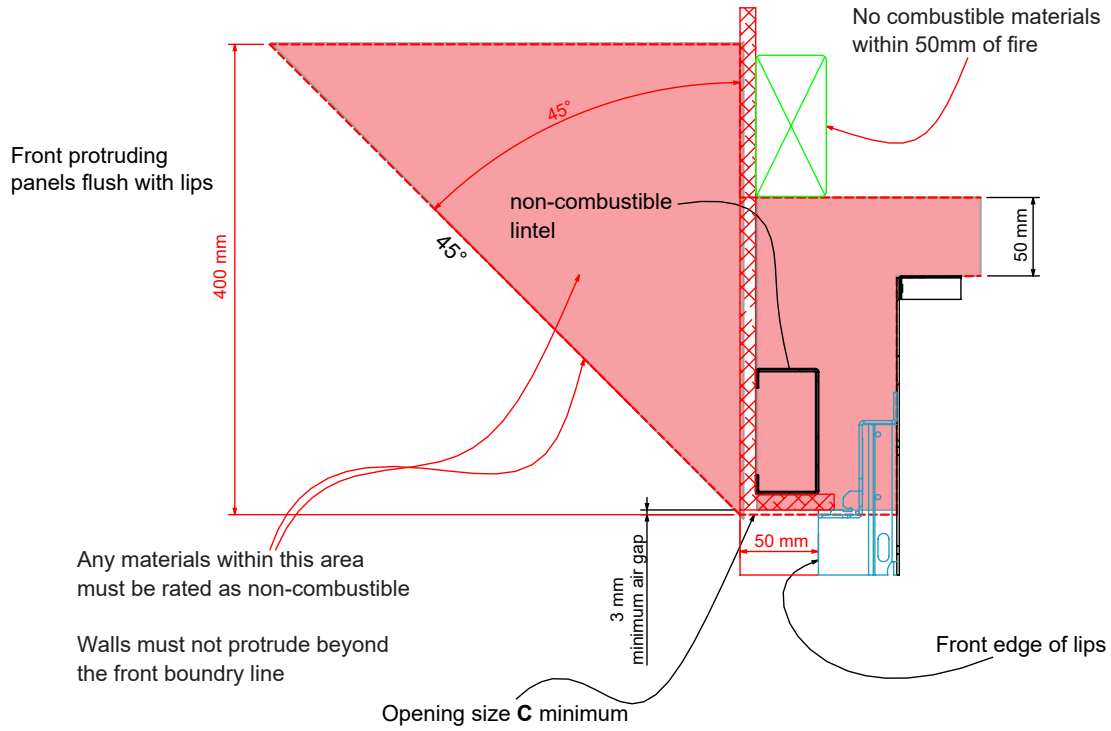

Rinnai.co.nz

Tel: 0800 746 624
<http://www.youtube.com/rinnainz>
<http://facebook.com/rinnainz>

Linear installation guide 13563-U