

Pro Series Ducted 13 kW indoor unit (DINLR13B1)

This diagram is provided to assist you to identify parts if replacement is necessary. Contact your place of purchase or the manufacturer to enquire about parts, availability and/or service.

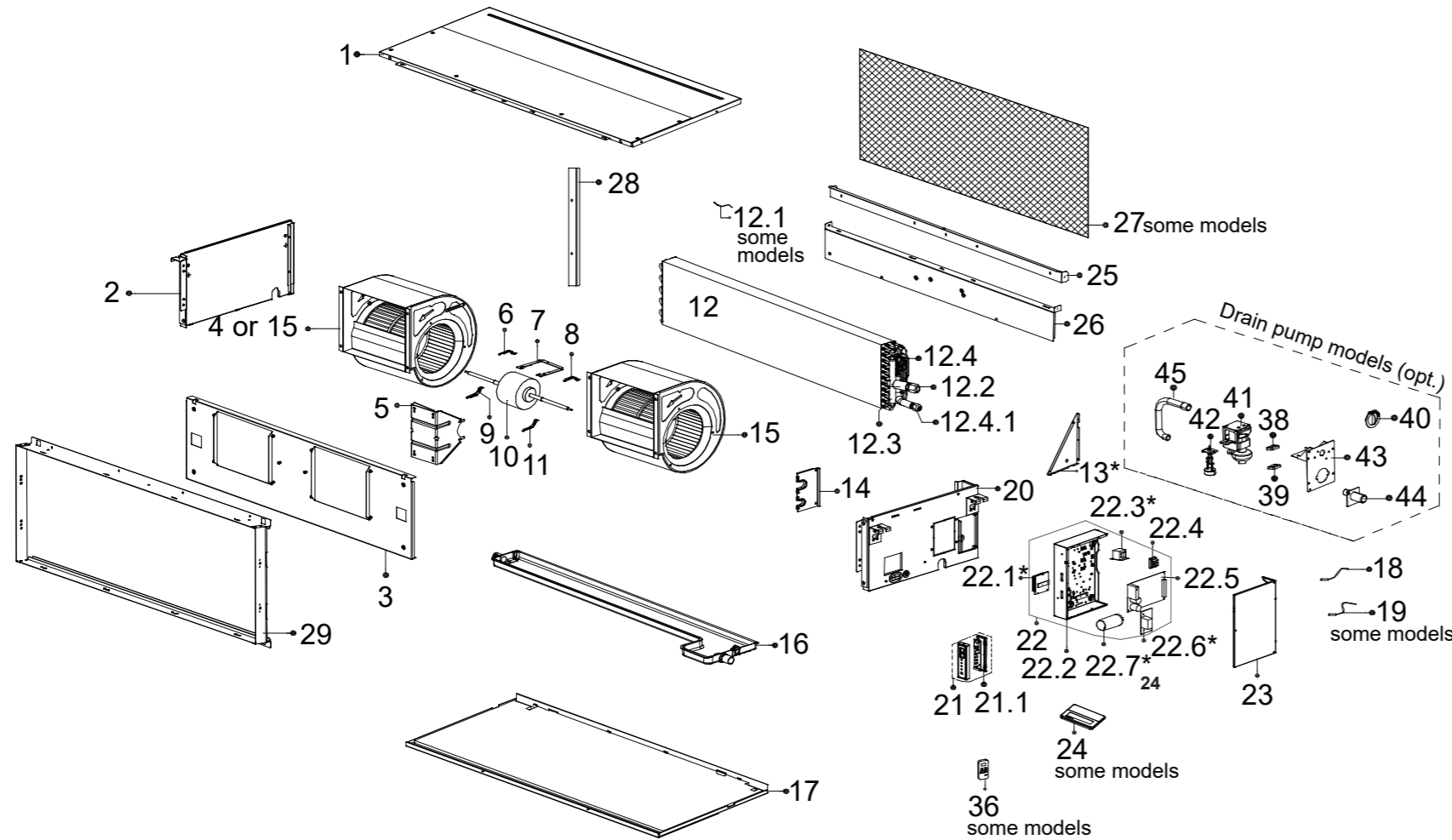

Ref.	Description (ID)	Part No.	
16	Water collector assembly	1212300000009	
17	Air duct bottom assembly	12223000A02180	
18	Room temperature sensor	11201007003426	14202
20	Right clapboard assembly	12223000A02849	
21	Duct display board sub-assembly	17223000000003	84000085
21.1	Duct display board sub-assembly	17123000002712	
22	Duct electronic control box sub-assy	17223000A07241	
22.2	Electronic control box	12223000008007	
22.3	Reactor	17400306000055	
22.4	Terminal	17400401000023	
22.5	Duct main control board sub-assy (indoor PCB)	17123000A03555	14229
22.6	Inverter module sub-assembly	17122000053868	
23	Cover of electronic control box	12223000008009	
24	Wired controller		
25	Flange board	12223000000474	
26	Flange sub-assembly	12223000000461	
28	Flange board	12223000000470	
29	Flange sub-assembly	12223000000460	
30	Flare nut	15500406000010	
31	Flare nut	15500406000003	
38	Drain pump rubber washer	12622500000004	
39	Drain pump rubber washer	12622500000003	
40	Cover of water testing hole	12123000000043	
41	Induction pump	11001010000063	
42	Water level sensor	11201005000006	
43	Exhaust pump sub-assembly	12223000A02732	
44	Drain hose	12100510000021	
46	Accessory kit	12011600A00310	

Ref.	Description (ID)	Part No.
1	Top cover assembly	12223000A02171
2	Left side plate assy. of cabinet	12223000A02174
3	Front clapboard assembly	12223000000139
5	Fan motor support	122230000000560
6	Fan motor cover	122230000000532
7	Fan motor fixing board	122230000000535
8	Fan motor cover	122230000000531
9	Fan motor cover	122230000000530

Ref.	Description (ID)	Part No.	
10	Brushless DC motor	11002015003861	14199
11	Fan motor cover	122230000000529	
12	Evaporator assembly	158230000006223	
12.1	Pipe temperature sensor	11201007003437	14201
12.3	Evaporator outlet pipe sub-assy	151230000000304	
12.4	Evaporator inlet pipe sub-assy	15123000011188	
14	Pipe clamp board sub-assy	12223000A02175	
15	Fan assembly	12200101000005	

This diagram is provided to assist you to identify parts if replacement is necessary. Contact your place of purchase or the manufacturer to enquire about parts, availability and/or service.

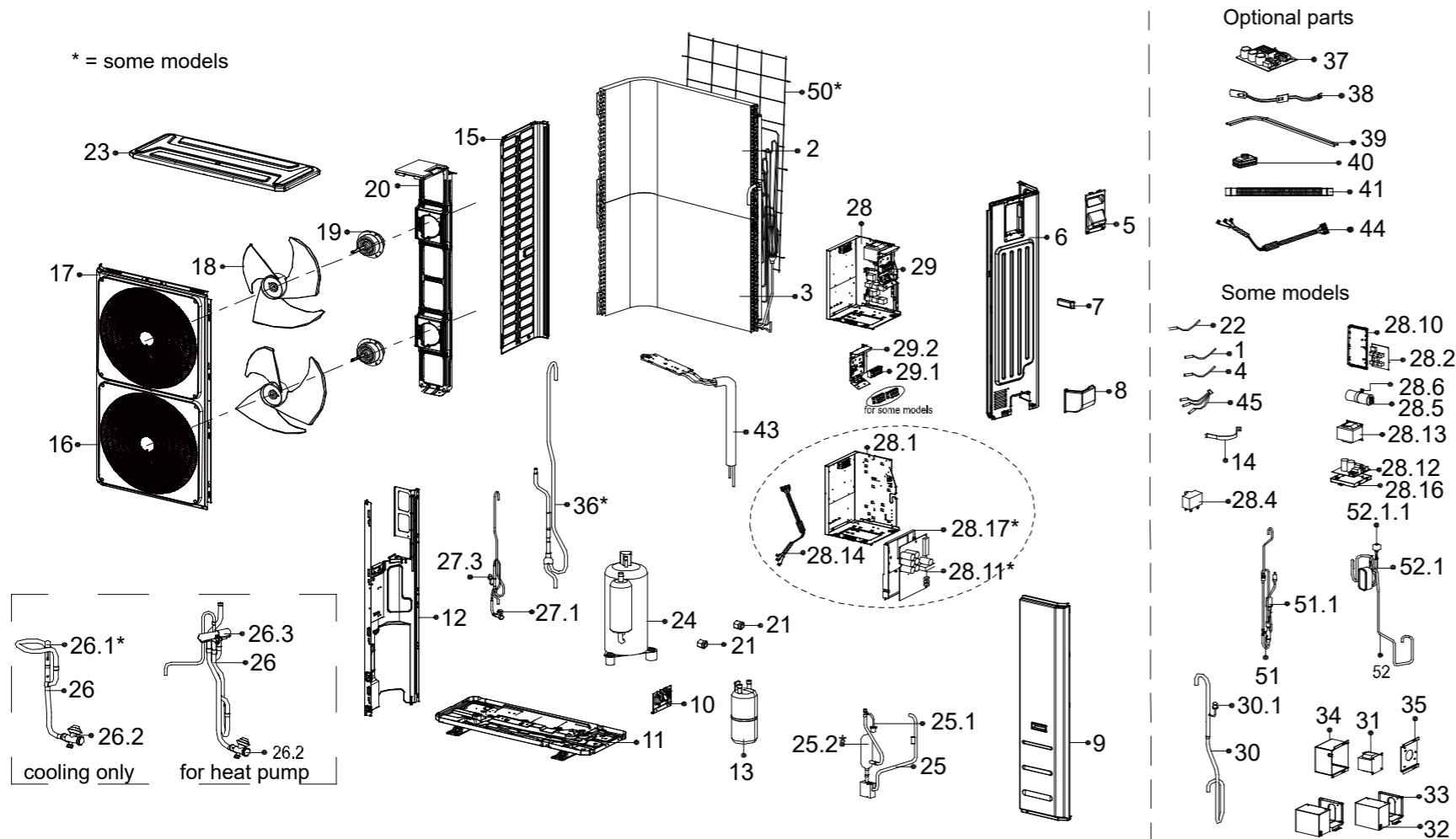

Ref.	Description (ID)	Part No.
1	Room temperature sensor	11201007003448 14164
2	Condenser assembly	15822000008539
3	Condenser assembly	15822000014448
4	Pipe temperature sensor	11201007003441 14203
5	Big handle assembly	12222000013365
6	Rear right clapboard assy	12222000016245
6.1	Handle	12100702000038
8	Water collector	12122000014023
9	Front right clapboard assy	12222000006287
10	Valve plate	12222000002361

Ref.	Description (ID)	Part No.
11	Chassis assembly	12222000006290
12	Partition board assembly	12222000005733
13	Liquid storage tank	15500508000009
15	Left side plate assy of cabinet	12222200002363
16	Air outlet grille	12122000020244
17	Front panel	12222000006291
18	Axial flow fan	12100105000022
19	Brushless DC motor	11002015009825 14204
20	Fan motor support sub-assy	12222000006288
21	Flare nut	15500406000003

Ref.	Description (ID)	Part No.
21	Flare nut	15500406000010
22	Discharge temperature sensor	11201007003124 14159
23	Top cover assembly	12222000002359
24	DC inverter rotary assembly	11103020002859
25	Discharge pipe assembly	15122000027660
25.1	Pressure switch	17400516000851 14183
26	4-way valve assembly	15422000019174
26.2	Gas valve	15500204000061
26.3	4-way valve	15500216000681
27	Liquid valve assembly (not shown)	15422000017113
27.1	Liquid valve	15500208000286
27.3	Electronic expansion valve	15500213002290
28	Electronic control box sub-assembly	17222000038806 14208
28.1	Installation plate of electric parts sub-assy	12222000012372
28.2	Inverter module sub-assembly	17122000062261
28.10	Electronic installing box	12122000020943
28.11	Outdoor main control board sub-assy	17122000057050
28.14	Compressor wires sub-assembly	17401203000936
28.17	Electronic installing box	12122000014342
28.21	Air duct	12122000020942
29	Terminal board sub-assembly	17222000038786 14209
29.1	Wire joint A	17400401000085
29.1	Terminal block	17400401000073
29.2	Terminal installation sub-assembly	12222000016246
29.4	Key board sub-assembly	17122000057048
29.5	DR module box sub-assembly	17222000038787
30	Suction pipe assembly	15122000026165
30.1	Pressure switch	17400516000008 14182
36	Throttle valve sub-assembly	15422000021855
43	Radiator sub-assembly	15122000024994
50	Rear net	12222000007944