

## Models

Outdoor	Indoor Pro Series High Wall	Indoor Slim Ducted	Indoor Cassette
MON3H07B	HINRP26MB	DINSD26MB	CIN026RMB
MON4H09B	HINRP35MB	DINSD35MB	CIN035RMB
MON5H11B	HINRP50MB	DINSD50MB	CIN050RMB
MON5H13B	HINRP60MB HINRP70MB	DINSD70MB	CINFASM (front panel)

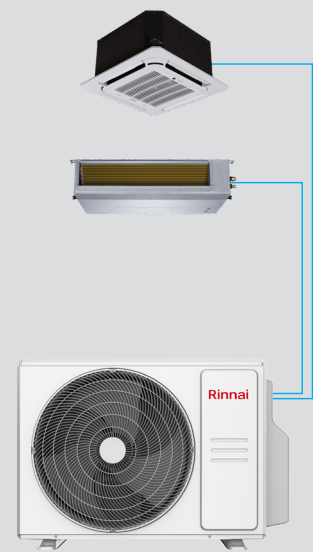
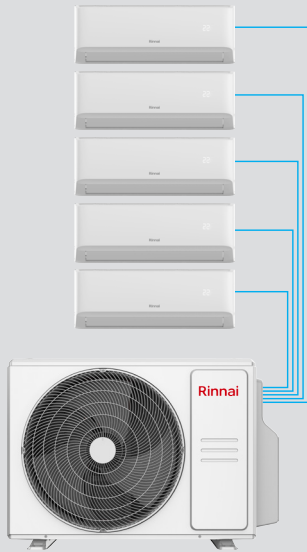

# Pro Series Multi Split System

## Installation guide

# Rinnai

---

# Important

---

This appliance must be installed in accordance with:

- Manufacturer's installation instructions
- Current AS/NZS 3000, AS/NZS 5141, AS/NZS 5419, AS/NZS 1677, AS/NZS 60335.2.40, and G12/AS1

Appliance must be installed, commissioned, serviced, and removed by an authorised person.

## **Warning**

Improper installation, adjustment, alteration, service and maintenance can cause property damage, personal injury or loss of life.

For more information about buying, using, and servicing of Rinnai appliances call: 0800 RINNAI (0800 746 624).

Rinnai New Zealand Limited  
105 Pavilion Drive, Mangere, Auckland  
PO Box 53177, Auckland Airport, Auckland 2150

Phone: (09) 257-3800  
Email: [info@rinnai.co.nz](mailto:info@rinnai.co.nz)  
Web: [rinnai.co.nz](http://rinnai.co.nz)  
[youtube.com/rinnainz](https://www.youtube.com/rinnainz)  
[facebook.com/rinnainz](https://www.facebook.com/rinnainz)

---

# Contents

---

Safety messages / important information .....	4
Specification summary .....	6
Installation parameters .....	9
Pro Series Indoor High Wall installation .....	10
Pro Series Indoor Slim ducted installation.....	14
Pro Series Indoor Cassette installation .....	21
Cassette panel installation.....	24
Outdoor unit installation.....	25
Outdoor unit installation - mounting dimensions...	27
Outdoor unit - drain joint and anchoring .....	28
Refrigerant piping connection.....	29
Wiring .....	31
Outdoor unit wiring .....	32
Outdoor unit wiring diagrams.....	33
Air evacuation.....	38
Adding refrigerant.....	39
Safety and leakage test.....	40
Test run.....	41
Automatic connection function.....	42
Commissioning .....	43
Error codes.....	44
Appendix 1: Mounting plate dimensions.....	46



Images in this guide are for illustration purposes. The system purchased may be slightly different in design.

# Safety messages / important information



This appliance is heavy, use two people or a mechanical lifting device. Improper lifting may result in serious injury.

For safety and warranty, appliances that are damaged **MUST NOT** be installed or operated under any circumstances.

## Electrical warnings

**DO NOT** modify the electrical wiring of this appliance. If the control power wiring is damaged or deteriorated then it must be replaced by an authorised person. Failure to do so may result in electric shock, fire, serious injury, or product failure.

All electrical connections **MUST** be made according to the wiring diagrams located on the panels of the indoor and outdoor units.

The PCB is designed with a fuse to provide overcurrent protection. The specifications of the fuse are printed on the PCB. For units using R32 refrigerant, only a blast-proof ceramic fuse can be used.

Power voltage should be within 90-110% of rated voltage. Insufficient power supply can cause a malfunction, electrical shock, or fire.

Only connect the unit to an individual branch circuit outlet. **DO NOT** connect another appliance to that outlet.

## Electrical wires

This is a Class 1 electrical appliance. Make sure the live wire, neutral wire, and earth wire in the power socket are properly connected. Inadequate or incorrect electrical connections may cause fire or electric shock.

The yellow-green wire in the air conditioner is the earthing wire which cannot be used for any other purpose. Improper earthing may cause electric shock. The unit must be earthed in accordance with local regulations.

Every wire must be firmly connected. Loose wiring can cause the terminal to overheat, resulting in a product malfunction and possible fire.

Do not let live wires touch or rest against refrigerant tubing, the compressor, or any moving parts within the unit.

## Circuit breaker

The circuit break must have the functions of magnetic tripping and heat tripping to prevent short circuiting and/or overload. Use a standard circuit breaker and fuse conforming with the rating of the appliance.

## Fixed wiring

If connecting power to fixed wiring<sup>1</sup>:

- A surge protector and mains power switch should be installed.
- A switch or circuit breaker that disconnects all poles and has a contact separation of at least  $\frac{1}{8}$ " (3 mm) must be incorporated in the fixed wiring.

<sup>1</sup> Consult a qualified electrician as it must comply with AS/NZS 5601 and AS/NZS 3000 and other relevant local regulations.

## R32 refrigerant

This system uses R32 (difluoromethane) refrigerant, which is a flammable gas, class 2.2 according to AS/NZS 1677 and must be handled by a qualified person with the appropriate refrigerant handling license.

Make sure to check for and rectify any refrigerant leaks after you install or repair the unit.

Certain levels of refrigerant require minimum room sizes, refer table below. Please ensure that these room sizes are adhered to for standard installations (up to 10 m pipe length). If larger refrigerant charges than standard are used then please consult AS/NZS 60335.2.40 to determine the safe minimum floor area for the installation.

Ensure the workspace is well-ventilated and completely free from any potential ignition sources before working on the refrigerant system.



Never mix refrigerant types.

Amount of refrigerant to be charged (kg)	Installation height (m)	Minimum room area (m <sup>2</sup> )	Amount of refrigerant to be charged (kg)	Installation height (m)	Minimum room area (m <sup>2</sup> )
1.00	0.6/1.8/2.2	9/1/1	1.95	0.6/1.8/2.2	33/4/2.5
1.05	0.6/1.8/2.2	9.5/1.5/1	2.00	0.6/1.8/2.2	34.5/4/3
1.10	0.6/1.8/2.2	10.5/1.5/1	2.05	0.6/1.8/2.2	36/4/3
1.15	0.6/1.8/2.2	11.5/1.5/1	2.10	0.6/1.8/2.2	38/4.5/3
1.20	0.6/1.8/2.2	12.5/1.5/1	2.15	0.6/1.8/2.2	40/4.5/3
1.25	0.6/1.8/2.2	13.5/1.5/1	2.20	0.6/1.8/2.2	41.5/5/3.5
1.30	0.6/1.8/2.2	14.5/2/1.5	2.25	0.6/1.8/2.2	43.5/5/3.5
1.35	0.6/1.8/2.2	16/2/1.5	2.30	0.6/1.8/2.2	45.5/5/3.5
1.40	0.6/1.8/2.2	17/2/1.5	2.35	0.6/1.8/2.2	47.5/5.5/4
1.45	0.6/1.8/2.2	18/2/1.5	2.40	0.6/1.8/2.2	49.5/5.5/4
1.50	0.6/1.8/2.2	19.5/2.5/1.5	2.45	0.6/1.8/2.2	51.5/6/4
1.55	0.6/1.8/2.2	21/2.5/2	2.50	0.6/1.8/2.2	54/6/4
1.60	0.6/1.8/2.2	22/2.5/2	2.55	0.6/1.8/2.2	56/6.5/4.5
1.65	0.6/1.8/2.2	23.5/3/2	2.60	0.6/1.8/2.2	58/6.5/4.5
1.70	0.6/1.8/2.2	25/3/2	2.65	0.6/1.8/2.2	60.5/7/4.5
1.75	0.6/1.8/2.2	26.5/3/2	2.70	0.6/1.8/2.2	63/7/5
1.80	0.6/1.8/2.2	28/3.5/2.5	2.75	0.6/1.8/2.2	65/7.5/5
1.85	0.6/1.8/2.2	29.5/3.5/2.5	2.80	0.6/1.8/2.2	67.5/7.5/5
1.90	0.6/1.8/2.2	31/3.5/2.5	2.85	0.6/1.8/2.2	70/8/5.5

- Mechanical connectors used indoors shall comply with ISO 14903
- When mechanical connectors are reused, sealing parts shall be renewed
- When flared joints are reused, the flare part shall be re-fabricated

# Specification summary



Outdoor unit		MON3H07B	MON4H09B	MON5H11B	MON5H13B
Number of indoor units		3	4	5	5
Power supply to outdoor unit		220-240 V 1 Ph 50 Hz			
Cooling	Rated capacity (kW)	7.5 (1.7-9.8)	9.15 (1.7-11.5)	12.0 (1.7-12.3)	13.0 (2.6-14.6)
	Rated input power (kW)	1.98	2.38	3.42	3.80
	Rated input current (A)	8.90	10.89	15.65	16.87
	AEER W/W	3.79	3.84	3.51	3.40
Heating	Rated capacity (kW)	7.4 (1.8-9.6)	9.6 (1.8-12.0)	12.5 (1.8-12.9)	13.5 (2.6-15.2)
	Rated input power (kW)	1.59	2.25	3.10	3.22
	Rated input current (A)	7.28	10.30	14.19	14.31
	ACOP W/W	3.80	3.86	3.43	4.20
Maximum input current		17.5 A	19.0 A	19.0 A	30.0 A
Compressor type		Inverter twin rotary			
Sound pressure level <sup>1</sup>		60 dB(A)	60 dB(A)	63 dB(A)	63 dB(A)
Sound power level <sup>1</sup>		65 dB(A)	68 dB(A)	72 dB(A)	72 dB(A)
Dimensions	Net (WxDxH) (mm)	890 x 342 x 673	946 x 410 x 810	946 x 410 x 810	980 x 451 x 975
	Gross (WxDxH) (mm)	1030 x 438 x 750	1090 x 500 x 885	1090 x 500 x 885	1145 x 500 x 1080
	Net / gross weight (kg)	48 / 51	66 / 72	76 / 82	91 / 106.4
Refrigerant type		R32			
Refrigerant piping	Connection size: Liquid line	3 x Ø6.35 mm	4 x Ø6.35 mm	5 x Ø6.35 mm	5 x Ø6.35 mm
	Connection size: Gas	3 x Ø9.52 mm	3 x Ø9.52 + 1 x Ø12.7 mm	4 x Ø9.52 + 1 x Ø12.7 mm	3 x Ø9.52 + 2 x Ø12.7 mm
	Maximum total system pipe length	60 m	80 m	80 m	80 m
	Pre-charged length	30 m	40 m	50 m	50 m
	Maximum length per indoor unit	30 m	35 m	35 m	35 m
	Maximum vertical separation outdoor unit ABOVE indoor unit	10 m	10 m	10 m	10 m
	Maximum vertical separation outdoor unit BELOW indoor unit	15 m	15 m	15 m	15 m
	Max. height difference between indoor units	10 m	10 m	10 m	10 m
24 °C ambient temp. limits	Cooling	-15-50 °C			
	Heating	-25-30 °C			



## <sup>1</sup>Sound pressure

Is what the listener (our ears hear). It is the pressure disturbance in the atmosphere, measured using predefined conditions, such as the location of the equipment, environmental conditions, and the distance from which the sound is measured. Sound pressure level focuses on how loud the noise is at a specific location, which can vary based on distance and surroundings.

## <sup>1</sup>Sound power

Measure of acoustic energy at the source. It quantifies the overall noise produced. Sound power level is a measure of how much noise the heat pump generates in total, irrespective of the distance from the source to the listener.



Pro Series High Wall Indoor		HINRP26MB	HINRP35MB	HINRP50MB	HINRP60MB	HINRP70MB
Power supply		220-240 V 1 Ph 50 Hz				
Cooling	Rated capacity	2.65 kW	3.5 kW	5.0 kW	6.0 kW	7.15 kW
	Rated input power	120 W	170 W	180 W	180 W	200 W
	Rated input current	2.5 A	3.8 A	5.8 A	8.0 A	10.5 A
Heating	Rated capacity	2.7 kW	3.8 kW	5.4 kW	6.5 kW	7.8 kW
	Rated input power	120 W	170 W	180 W	180 W	200 W
	Rated input current	2.5 A	5 A	6 A	8.2 A	10.8 A
Airflo (turbo, hi, med, lo, min) L/s		175 / 139 / 100 / 85 / 56	183 / 147 / 106 / 86 / 58	264 / 222 / 167 / 139 / 89	264 / 222 / 167 / 139 / 89	382 / 303 / 250 / 229 / 147
Sound power level		55.3 dB(A)	56.4 dB(A)	59.8 dB(A)	59.8 dB(A)	62.2 dB(A)
Dimensions	Net (WxDxH) mm	802 x 200 x 295	802 x 200 x 295	971 x 228 x 321	971 x 228 x 321	1082 x 234 x 337
	Gross (WxDxH) mm	965 x 370 x 282	1010 x 385 x 307	1067 x 385 x 312	1205 x 400 x 317	1082 x 234 x 337
	Net / gross weight	8.5 / 11.1 kg	8.5 / 11.1 kg	11.1 / 14.4 kg	11.1 / 14.4 kg	13.5 / 17.1 kg
	Refrig. pipe size: Liq. / gas (mm)	Ø6.35 / Ø9.52	Ø6.35 / Ø9.52	Ø6.35 / Ø12.7	Ø6.35 / Ø12.7	Ø6.35 / Ø15.9
Controller		Wireless remote controller				
Operating range	Cooling	16~32 °C				
	Heating	0~30 °C				
Wireless compatibility		Standard				



Slim Ducted Indoor		DINSD26MB	DINSD35MB	DINSD50MB	DINSD70MB
Power supply		220-240 V 1 Ph 50 Hz			
Cooling	Rated capacity	2.6 kW	3.5 kW	5.2 kW	7.1 kW
	Rated input power	180 W	185 W	200 W	200 W
	Rated input current	1.1 A	1.1 A	1.3 A	1.3 A
Heating	Rated capacity	2.9 kW	3.8 kW	5.5 kW	7.3 kW
	Rated input power	180 W	185 W	200 W	200 W
	Rated input current	1.1 A	1.1 A	1.3 A	1.3 A
Airflo (hi, med, lo) m³/h		500 / 340 / 230	500 / 340 / 230	600 / 480 / 300	880 / 650 / 350
Max. external static pressure (hi)		60 Pa	60 Pa	100 Pa	160 Pa
Sound pressure (hi, med, lo) @ 1 m dB(A)		40 / 34 / 27	40 / 34 / 27	40 / 34 / 27	41 / 38 / 33
Dimensions	Net (WxDxH) mm	700 x 506 x 200	700 x 506 x 200	880 x 674 x 200	1100 x 774 x 249
	Gross (WxDxH) mm	860 x 540 x 285	860 x 540 x 285	1070 x 725 x 280	1305 x 805 x 315
	Net / gross weight	18 / 22 kg	18 / 22 kg	24 / 29 kg	32 / 39 kg
	Supply air duct connection (WxH) mm	537 x 152	537 x 152	706 x 136	926 x 175
	Return air duct connection (WxH) mm	599 x 186	599 x 186	782 x 190	1001 x 228
	Refrig. pipe size: Liq. / gas (mm)	Ø6.35 / Ø9.52	Ø6.35 / Ø12.7	Ø6.35 / Ø9.52	Ø9.52 / Ø15.9
Condensate drain pump connection		OD Ø25 mm			
Controller		Wired controller			
Operating range	Cooling	17~32 °C			
	Heating	0~30 °C			
Wireless compatibility		Standard			



Compact Cassette Indoor		CIN026RMB	CIN035RMB	CIN050RMB
Power supply		220-240 V 1 Ph 50 Hz		
Cooling	Rated capacity	2.6 kW	3.5 kW	5.3 kW
	Rated input power	145 W	150 W	150 W
	Rated input current	0.14 A	0.18 A	0.18 A
Heating	Rated capacity	2.9 kW	4.10 kW	5.40 kW
	Rated input power	145 W	150 W	150 W
	Rated input current	0.14 A	0.18 A	0.18 A
Airflo (hi, med, lo) m <sup>3</sup> /h		580 / 500 / 450	569 / 485 / 389	680 / 584 / 479
Sound pressure (hi, med, lo) @ 1 m dB(A)		38 / 33 / 29	41 / 37 / 34	44 / 42 / 41
Dimensions	Net body (WxDxH) mm	570 x 570 x 260	570 x 570 x 260	570 x 570 x 260
	Gross body (WxDxH) mm	662 x 663 x 317	662 x 663 x 317	662 x 663 x 317
	Net fascia (WxDxH) mm	650 x 650 x 60	650 x 650 x 60	650 x 650 x 60
	Gross fascia (WxDxH) mm	700 x 700 x 110	700 x 700 x 110	700 x 700 x 110
	Net / gross weight body	14 / 17 kg	16 / 20 kg	16 / 21 kg
	Net / gross weight fascia	2 / 4 kg	2 / 4 kg	2 / 4 kg
	Refrig. pipe size: Liq. / gas (mm)	Ø6.35 / Ø9.52	Ø6.35 / Ø9.52	Ø6.35 / Ø12.7
Condensate drain pump connection		OD Ø25 mm		
Controller		Wireless remote		
Operating range	Cooling	17-32 °C		
	Heating	0-30 °C		
Wireless compatibility		Optional		



# Installation parameters

- Number of units that can be used together 5
- Compressor stop/start frequency 3 minutes or more
- Power voltage fluctuation within  $\pm 10\%$  of rated voltage
- Power voltage drop during start within  $\pm 15\%$  of rated voltage
- Power interval unbalance within  $\pm 3\%$  of rated voltage

When installing multiple indoor units with a single outdoor unit, ensure that the length of the refrigerant pipe and drop height between the indoor and outdoor units meet the requirements shown below.

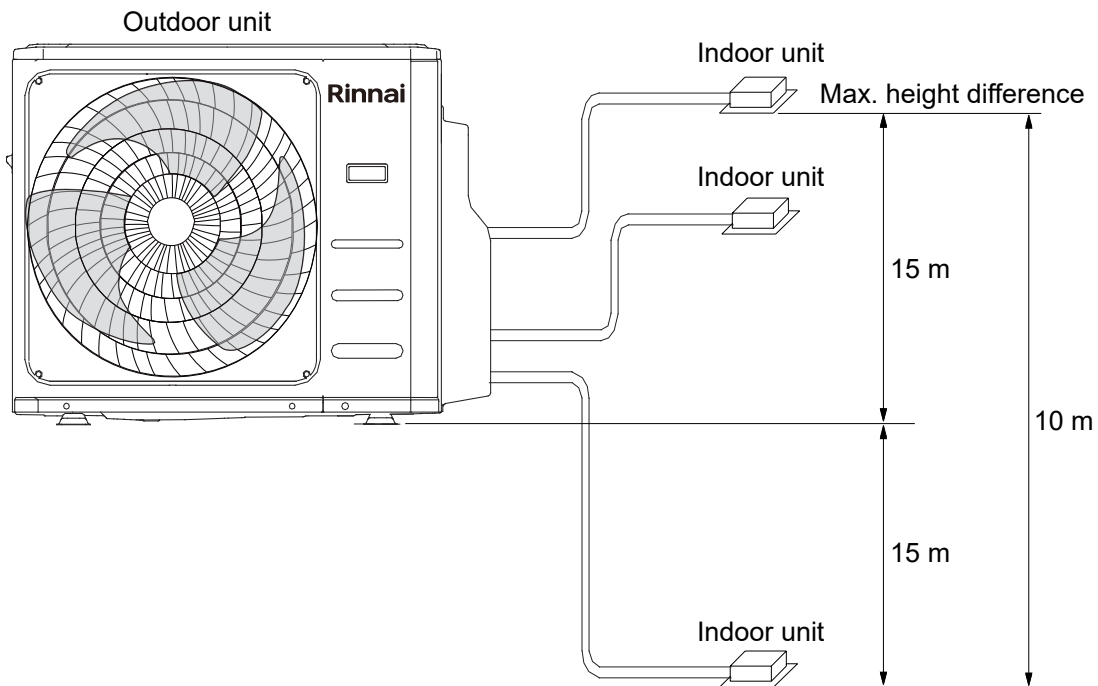

A minimum pipe run of three metres is required to minimise vibration and excessive noise.

# Pro Series Indoor High Wall installation

## Installation overview

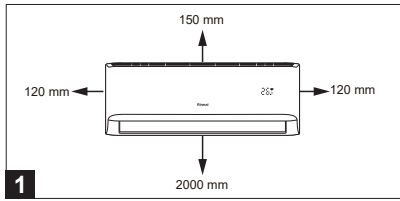

1 Select installation location.

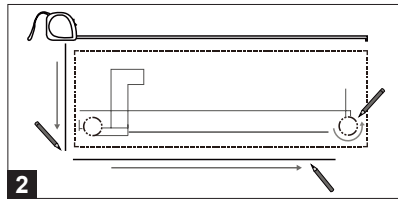

2 Determine wall hole position.

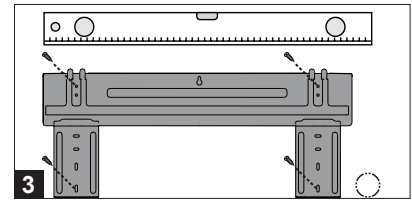

3 Attach mounting plate.

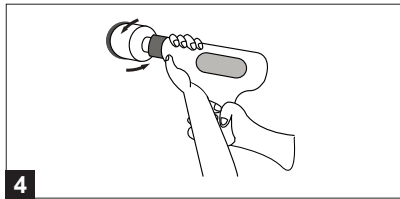

4 Drill hole in wall.

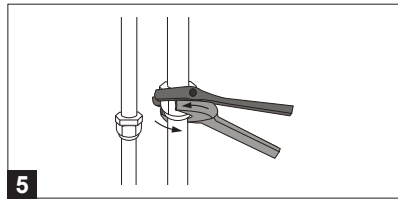

5 Connect piping.

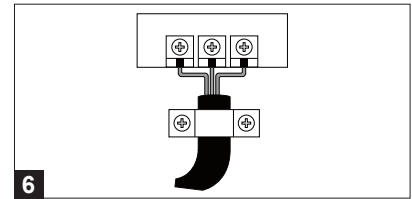

6 Connect wiring.

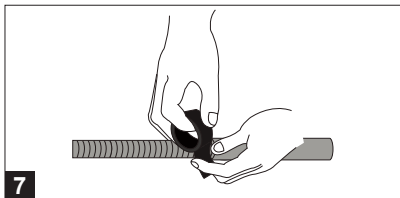

7 Prepare drain hose.

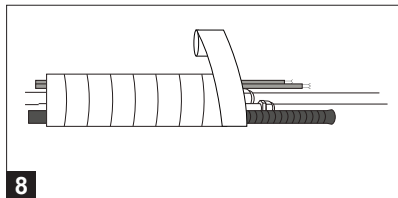

8 Wrap pipe and cable.

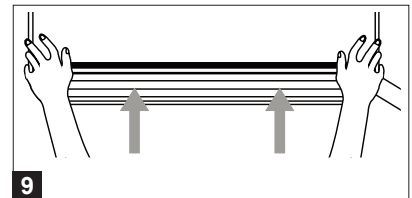

9 Mount indoor unit.

## Positioning and clearances

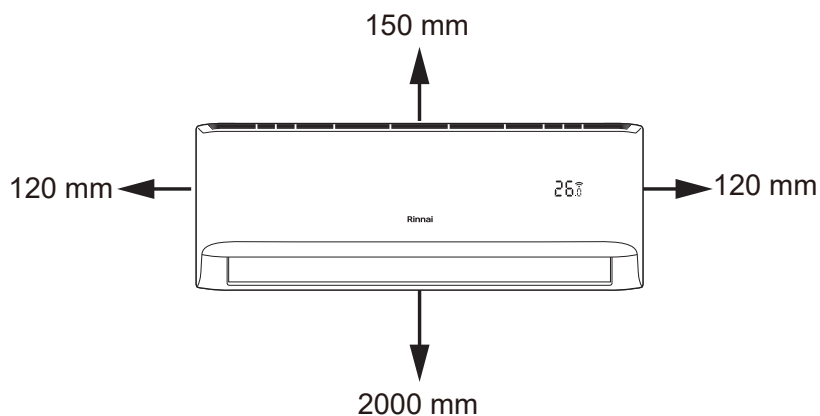

Ensure the following:

- Good air circulation
- Convenient drainage
- Noise from the unit will not disturb others
- Firm and solid—location will not vibrate
- At least 1 m from other electrical devices (e.g. TV, radio, computer)

DO NOT install:

- Near a doorway
- In a location subject to direct sunlight
- Near any source of heat, steam, or combustible gas
- Near combustible items such as curtains or clothing
- Near any obstacle that may block air circulation

Install the unit on a wall that can support the unit's weight. If the chosen location cannot support the unit's weight, or the installation is not done properly, the unit may drop and cause serious injury and damage.

Do not install the unit in a location that may be exposed to combustible gas leaks. If combustible gas accumulates around the unit, it may cause a fire.

For R32 refrigerant models, appliance shall be installed and operated in a room with a floor area larger than 4 m<sup>2</sup>.

When choosing a location be aware that there needs to be ample room for a hole for the signal cable and refrigerant piping that connects the indoor and outdoor units. The default position for all piping is to the right side of the indoor unit. However the unit can accommodate piping to the left and right.

### 1. Select installation location

Refer notes and clearances diagram on previous page.

### 2. Attach mounting plate to wall, refer dimensions on p.42

- Remove the screw that attaches the mounting plate to the back of the indoor unit.
- Secure the mounting plate to the wall with the screws provided. Make sure the mounting plate is flat against the wall.

If the wall is made of brick, concrete, or similar, drill 5 mm diameter holes in the wall and insert sleeve anchors. Secure the mounting plate to the wall by tightening the screws directly to the clip anchors.

### 3. Drill hole in wall for connective piping

Determine the location of the hole in the wall based on the position of the mounting plate.

Using a 65 mm or 75 mm core drill, drill a hole in the wall. When drilling make sure to avoid wires, plumbing, and other sensitive components. Make sure that the hole is drilled at a slight downward angle, so that the outdoor end of the hole is lower than the indoor end by approximately 5-7 mm. This will ensure the water drains properly.

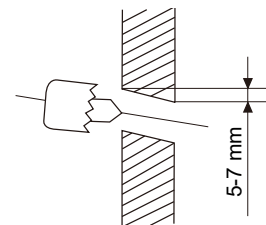

Place the protective wall cuff in the hole. This protects the edges of the hole and will help seal it when the installation is finished.

### 4. Prepare refrigerant piping

The refrigerant piping is inside an insulating sleeve which is attached to the back of the unit. You must prepare the piping before passing it through the hole in the wall.

Based on the position of the hole in the wall relative to the mounting plate, choose the side from which the piping will exit the unit. If the hole is behind the unit, keep the knockout panel in place. If the hole is to the side of the indoor unit, remove the plastic knockout panel from that side of the unit. This will create a slot through which your piping can exit. Use needle nose pliers if the plastic panel is too difficult to remove by hand.

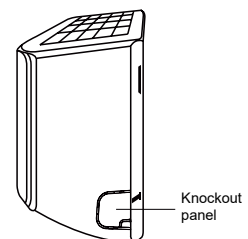

Connect the indoor unit's refrigerant piping to the connective piping that will join the indoor and outdoor unit. Be careful not to dent or damage the piping while bending away from the unit. Any dents in the piping will affect the unit's performance.

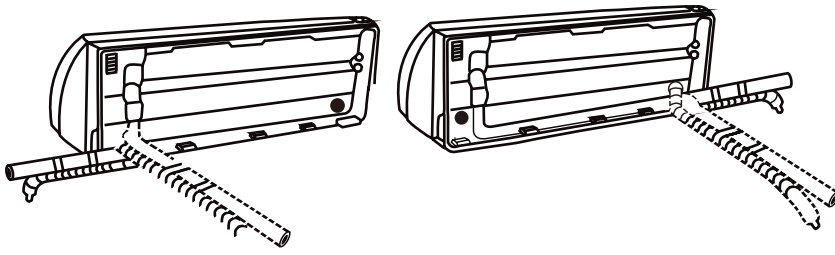

Refrigerant piping can exit the indoor unit from four different angles; left-hand side, right-hand side, left rear, and right rear.

## 5. Connect drain hose

The drain hose is attached to the left-hand side of the unit. However, it can also be attached to the right-hand side. To ensure proper drainage attach the drain hose on the same side that your refrigerant piping exits the unit. Attach the drain hose extension (purchased separately) to the end of the drain hose.

Wrap the connection point firmly with Teflon tape to ensure a good seal to prevent leaks. For the portion of drain hose that will remain indoors, wrap it with foam pipe insulation to prevent condensation.

Remove the air filter and pour a small amount of water into the drain pan to make sure that water flows from the unit correctly. To prevent unwanted leaks plug the unused drain hole with the rubber plug provided.

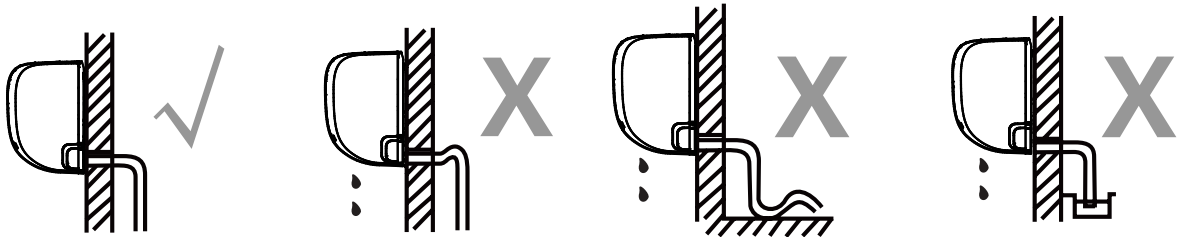
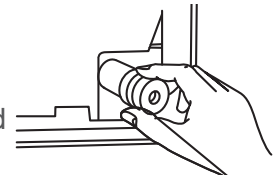

**CORRECT**  
Make sure there are no kinks or dents in the drain hose to ensure proper drainage

**INCORRECT**  
Kinks in the drain hose will create water traps.

**INCORRECT**  
Kinks in the drain hose will create water traps.

**INCORRECT**  
Do not place the end in water or other containers that collect water. This will prevent proper drainage.

## 6. Connect signal and power cables



Before performing any electrical or wiring work, turn off the mains power to the system. All wiring must be performed in accordance with the wiring diagram located on the back of the indoor unit's front panel.

The signal cable enables communication between the indoor and outdoor units. You must choose the right cable size before preparing it for connection. The size of the power supply cable, signal cable, fuse, and switch is determined by the maximum current of the unit. The maximum current is indicated on the data plate located on the side panel of the unit.

1. Open the front panel of the indoor unit.
2. Using a screwdriver, open the wire box cover on the right side of the unit, this will reveal the terminal block.
3. Unscrew the cable clamp below the terminal block and place it to the side.
4. Facing the back of the unit, remove the plastic panel on the bottom left-hand side.

## 6. Connect signal and power cables continued

5. Feed the signal wire through the slot, from the back of the unit to the front.
6. Facing the front of the unit, connect the wires according to the wiring diagram, connect the u-lug and firmly screw each wire to its corresponding terminal.
7. Make sure every connection is secure, use the cable clamp to fasten the signal cable to the unit. Screw the cable clamp down tightly.
8. Replace the wire box cover on the front of the unit, and the plastic panel on the back.

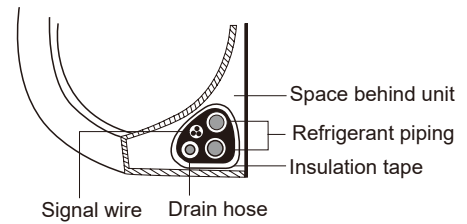

## 7. Wrap piping and cables

Before passing the piping, drain hose, and the signal cable through the wall, bundle them together to save space, protect and insulate them.

Bundle the drain hose, refrigerant pipes, and signal cable as shown above. Make sure the drain hose is at the bottom of the bundle. Putting the drain hose at the top can cause the drain pan to overflow, which can lead to fire or water damage.

While bundling, DO NOT intertwine or cross the signal cable with any other wiring.

Using adhesive vinyl tape, attach the drain hose to the underside of the refrigerant pipes. Using insulation tape, wrap the signal wire, refrigerant pipes, and drain hose tightly together. When wrapping the bundle keep the ends of the piping unwrapped so they can be tested for leaks at the end of the installation process.

## 8. Mount indoor unit

1. Check the ends of the refrigerant pipes are sealed to prevent dirt or foreign materials from entering the pipes.
2. Slowly pass the wrapped bundle of refrigerant pipes, drain hose, and signal wire through the hole in the wall.
3. Hook the top of the indoor unit on the upper hook of the mounting plate. Check that the unit is hooked firmly by applying slight pressure to the left and right-hand sides of the unit. The unit should not move.
4. Using even pressure, push down on the bottom half of the unit. Keep pushing down until the unit snaps onto the hooks along the bottom of the mounting plate. Check that the unit is firmly mounted.

If the refrigerant piping is already embedded in the wall do the following:

1. Hook the top of the indoor unit on the upper hook of the mounting plate.
2. Use a bracket or wedge to prop up the unit, giving you enough room to connect the refrigerant piping, signal cable, and drain hose.
3. Connect drain hose and refrigerant piping, refer previous pages.
4. Keep the pipe connection points exposed to perform the leak test. After the leak test wrap the connection points with insulation tape.
5. Remove the bracket or wedge that is propping up the unit, and using even pressure, push down on the bottom half of the unit. Keep pushing down until the unit snaps onto the hooks along the bottom of the mounting plate.



**Unit is adjustable:** The hooks on the mounting plate are smaller than the holes on the back of the unit. If you find you don't have enough room to connect embedded pipes to the indoor unit, the unit can be adjusted left or right by 30-50 mm, depending on the model.

# Pro Series Indoor Slim Ducted installation

## Positioning and clearances

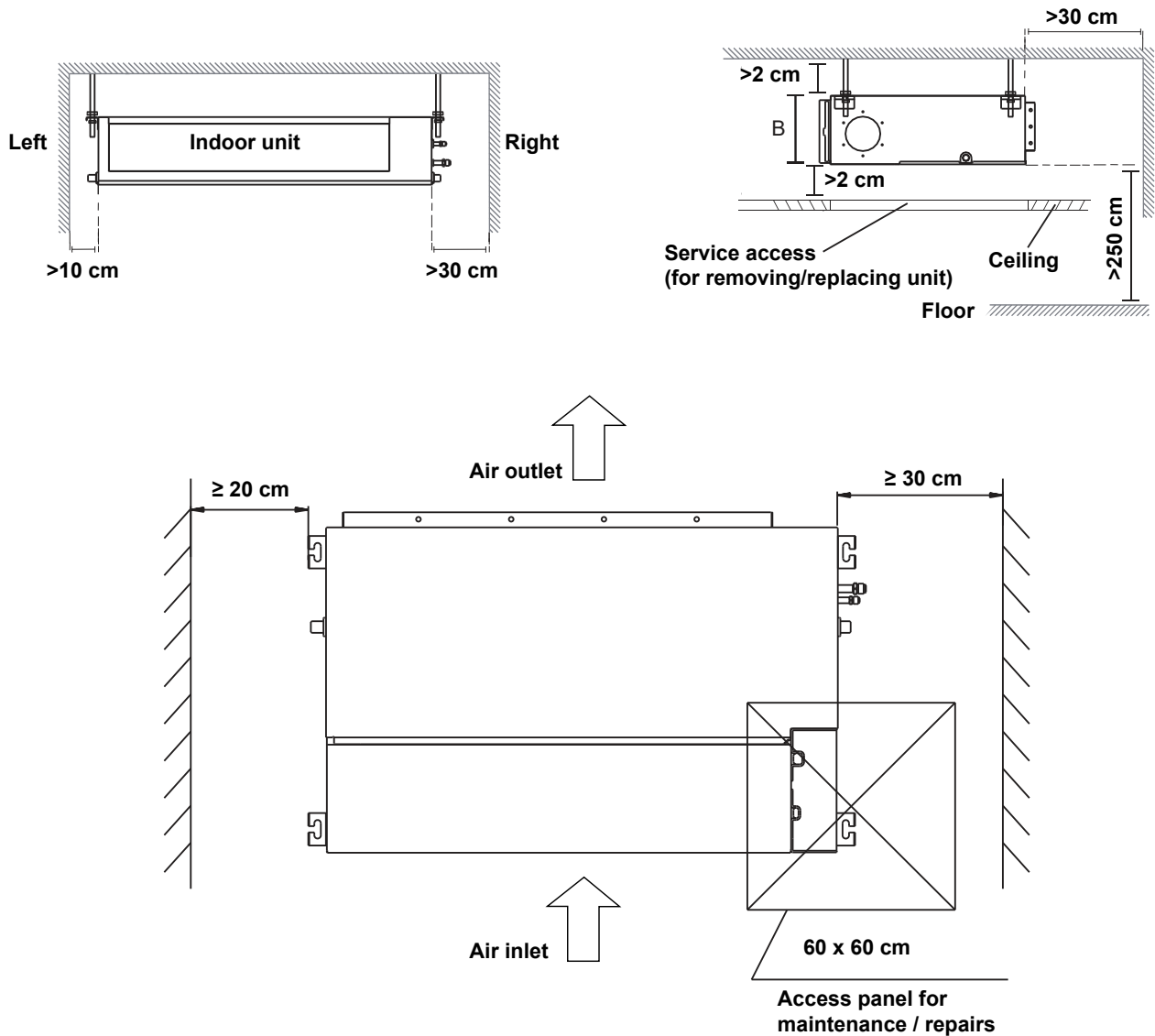

### Ensure the following:

- Good air circulation
- Enough room for installation / maintenance
- Structure can sustain weight of unit
- Convenient drainage
- Air inlet and outlet are not impeded
- Airflow adequate for room size
- No direct radiation from heaters
- Firm and solid—location will not vibrate
- At least 1 m from other electrical devices (e.g. TV) to prevent static interference

### DO NOT install:

- In rooms with high humidity such as bathrooms or laundry rooms
- In enclosed spaces
- Areas that store flammable materials or gas
- Buildings that may experience power fluctuation

## Hang indoor unit

Locate the four positioning screw bolt holes on the ceiling, and mark where the ceiling hook holes will be drilled.

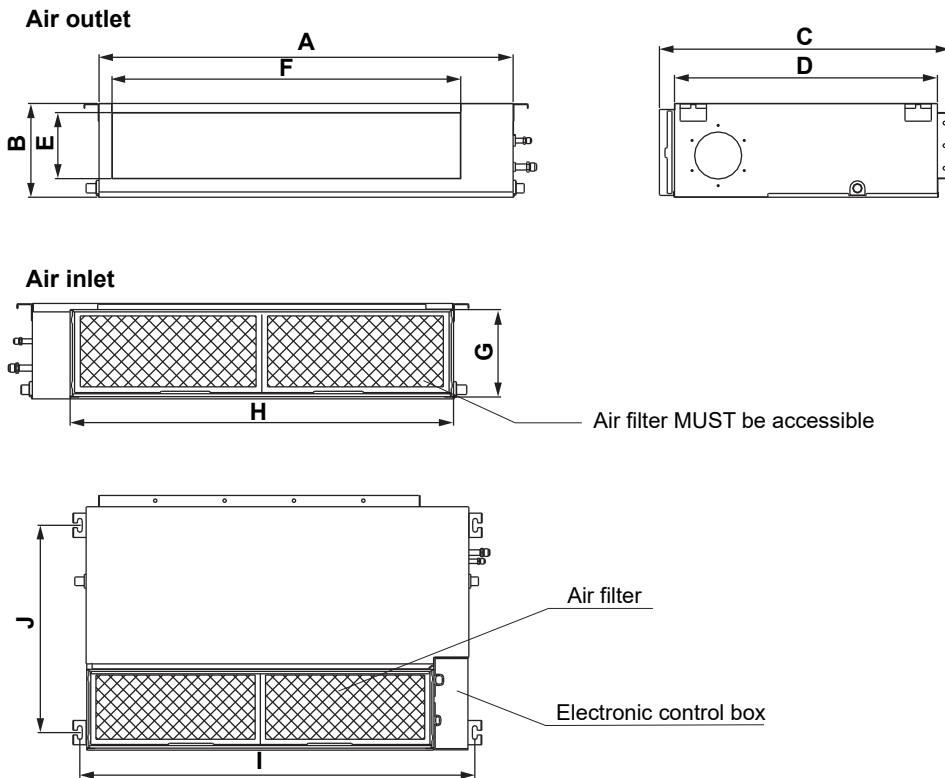

### Dimensions (mm)

Model	Outline dimension				Air outlet opening size		Air return opening size		Size of mounted lug	
	A	B	C	D	E	F	G	H	I	J
DINSD26MB	700	200	506	450	152	537	186	600	741	360
DINSD35MB										
DINSD50MB	880	210	674	600	136	706	190	782	920	508
DINSD70MB	1100	249	774	700	175	926	228	1000	1140	600

### Wood

Place the mounting screws across the roof beam, then install the hanging screw bolts.

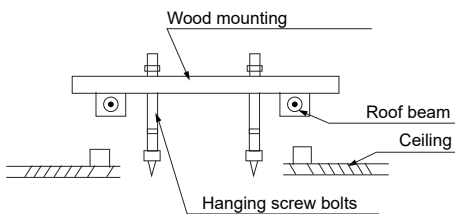

### Original concrete bricks

Use an embedding screw bolt, crock, and stick harness.

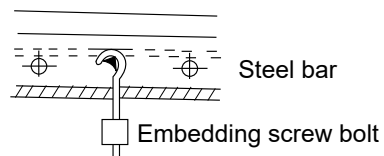

### Steel roof beam structure

Install and use the supporting steel angle.

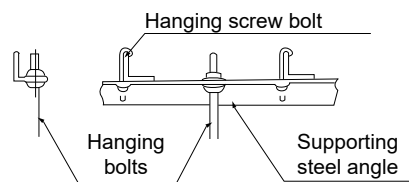

### New concrete bricks

Inlay or embed the screw bolts.



Blade shape insertion

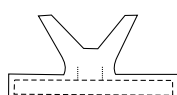

Slide insertion

## Mount indoor unit

Before starting ensure the unit is completely aligned with the mounting holes.

1. Install and fit pipes (and wires). When choosing where to start, determine the direction of the pipes to be drawn out. Align the refrigerant pipes, drain pipes, and indoor and outdoor lines with their connection points before mounting the unit.
2. Install hanging screw bolts. Drill four holes 10 cm deep at the ceiling hook positions in the internal ceiling. Be sure to hold the drill at a 90° angle to the ceiling. Secure the bolts using the washers and nuts provided. Install the four suspension bolts.
3. Mount the indoor unit with at least two people to lift and secure it. Insert suspension bolts into the unit's hanging holes. Fasten them using the washers and nuts provided.
4. Mount the unit onto the hanging screw bolts with a block. Ensure the unit is level. If not level leaks could occur.
5. Install the filter(s), and install the canvas tie-in (non-flammable to prevent vibrating) between the body and the duct. The air inlet and air outlet duct should be far enough apart to avoid an air passage short-circuit. Connect the duct according to diagram below.
  - Do not place the connecting duct weight on the indoor unit.
  - Insulation foam must be wrapped outside the duct to avoid condensate.
6. Change the fan motor static pressure according to external duct static pressure, see page 20.

Model	Static pressure
DINSD26MB	0~60 pa
DINSD35MB	0~60 pa
DINSD50MB	0~100 pa
DINSD70MB	0~160 pa

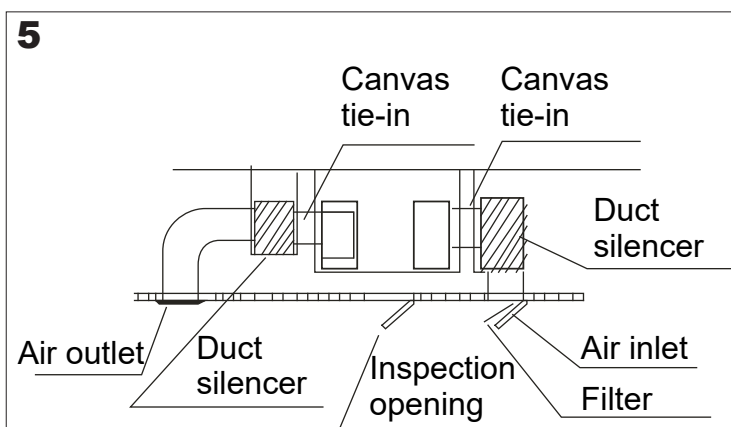
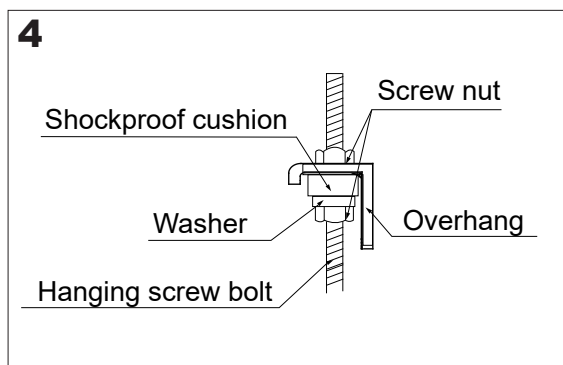
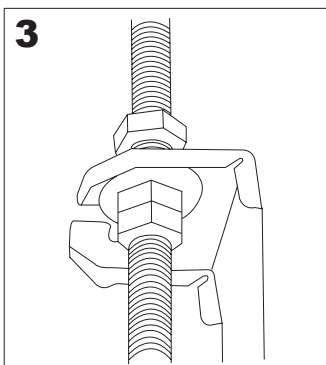



## Adjustments

How to adjust the air inlet direction—takeoff the ventilation panel and flange.

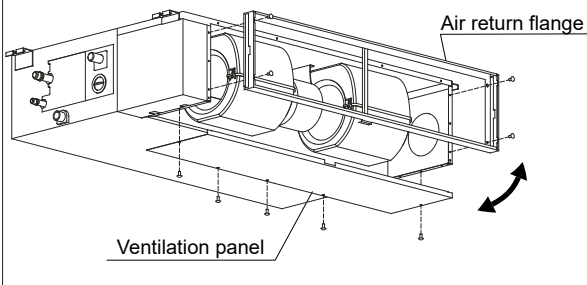

Fresh air duct installation (where fitted).

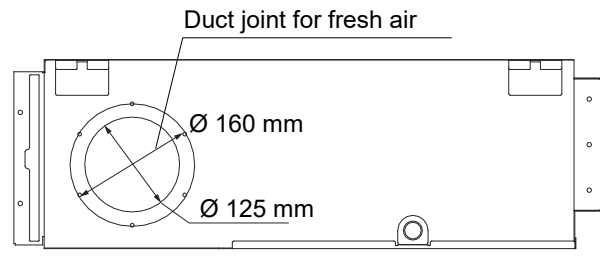

Changing the mounting positions of the ventilation panel and return air flange.

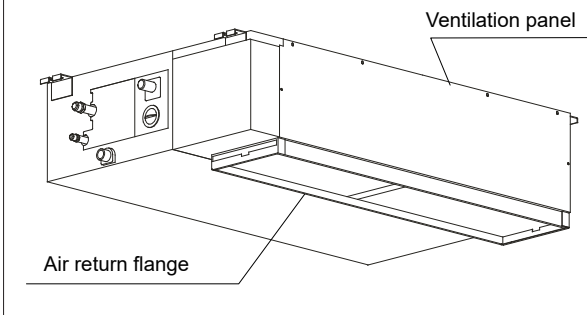

Motor and drain pump maintenance.

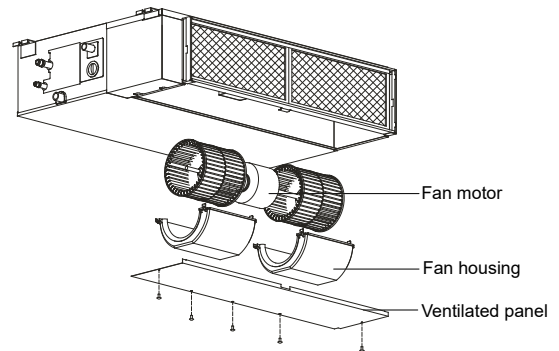

Filter installation.

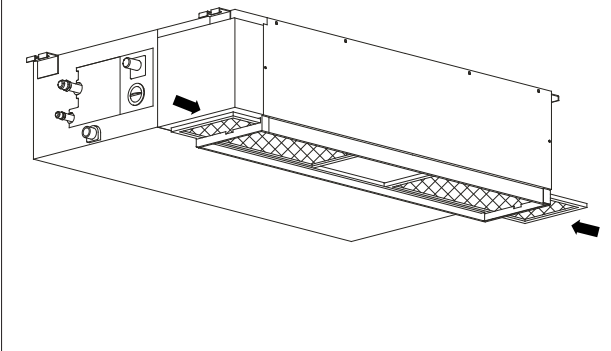

Pump access.

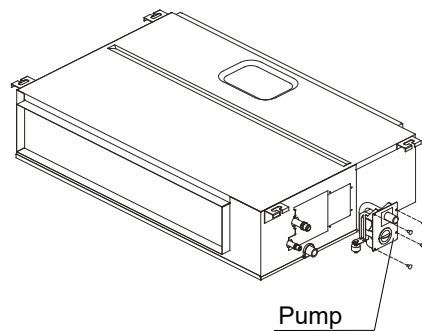

## Drainpipe installation

The drainpipe is used to drain water away from the unit. Improper installation may cause unit and property damage.

- **Insulate all piping to prevent condensation which could lead to water damage.**
- If the pipe is bent or installed correctly water may leak and cause a water level switch error.
- Ensure the drain hose is placed in an appropriate area to avoid water damage and injury if the drain water has frozen.

This installation requires polyethylene tube (outside diameter 3.7-3.9 cm, inside diameter 3.2 cm).

1. Install the drainpipe as shown below.

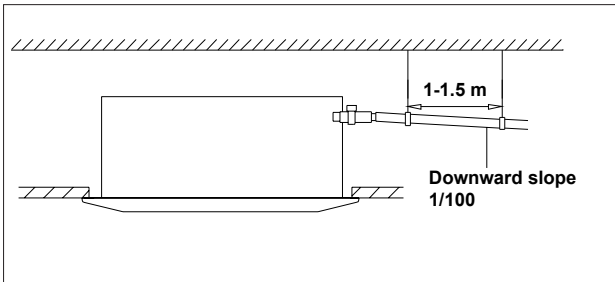

Cover the drainpipe with insulation. Attach the mouth of the drain hose to the unit's outlet pipe. Sheath the mouth of the hose and clip it firmly with a pipe clasp.

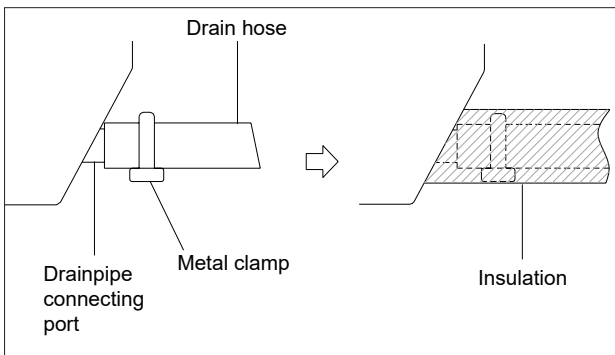

### 2. Extended drainpipe

When using an extended drainpipe, tighten the indoor connection with an additional protection tube to prevent it from pulling loose.

The drainpipe should slope downward at a gradient of at least 1/100 to prevent water from flowing back into the unit. To prevent sagging space hanging wires every 1-1.5 m.

If the outlet of the drainpipe is higher than the body's pump joint, provide a lift pipe for the exhaust outlet of the indoor unit. The lift pipe must be installed no higher than 75 cm from the ceiling board, and the distance between the unit and the lift pipe must be less than 30 cm. Incorrect installation could cause water to flow back into the unit and flood.

To prevent air bubbles, keep the drain hose level or slightly tilted up (<75 mm), refer diagram below.

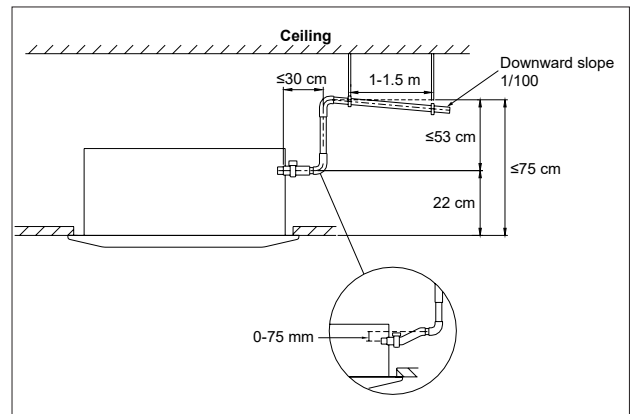

### 3. Multiple drainpipes

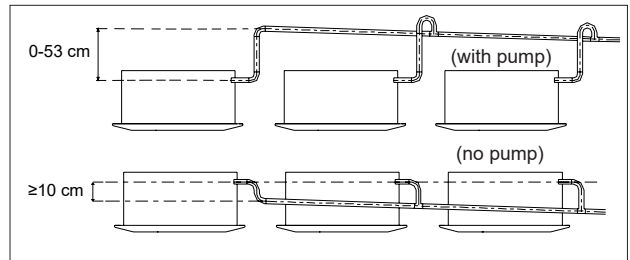

### 4. Installation continued

Using a core drill, drill a hole in the wall. Make sure that the hole is drilled at a slight downward angle, so that the outdoor end of the pipe is lower than the indoor end by approx. 12 mm. This will ensure proper drainage.

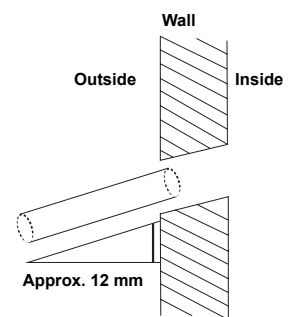

Place the protective wall cuff in the hole. This protects the edges of the hole and will help seal it.

Pass the drain hose through the hole in the wall. Make sure the water drains to a safe location where it not will cause water damage or create a slipping hazard.

The drainpipe outlet should be at least 5 cm above the ground. If it touches the ground, the unit may become blocked and malfunction.

If you discharge the water directly into a sewer, make sure that the drain has a U or S pipe to catch odours that may come back into the house.

## 5. Drainage test

Check that the drainpipe is unhindered. In new builds this test should be done before lining the ceiling.

1. Remove the test cap and pour two litres of water into the condensate pan.
2. Operate the unit in COOLING mode. Confirm the condensate pump turns on and begins to remove the two litres of water. This should take approximately one minute. Check for leaks during this time.
3. Power off the unit and replace the cap.

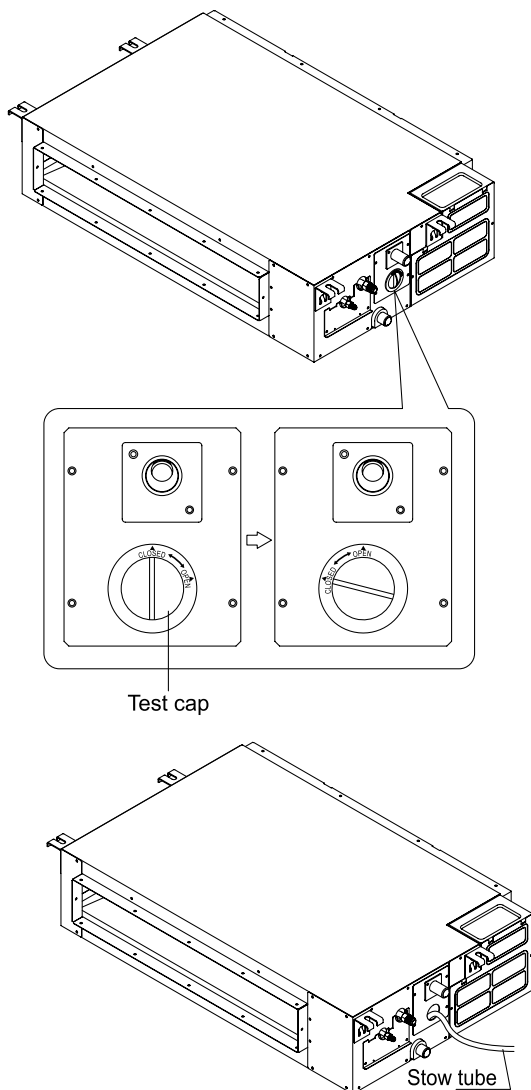

## System settings

### Fan speed settings

Setting the fan speed and / or external static pressure settings can be done automatically or manually, using the wired controller.

### Auto fan setting

The system will automatically adjust the fan setting based on the system static pressure. When the system is off, perform the following steps using the wired controller. Do not adjust the dampers during this time.

1. Press the COPY button and hold for three seconds.
2. Press the + button to select AF.
3. Press the CONFIRM button, the unit will start the fan operation airflow auto adjustment.
4. After three to six minutes the unit will stop and the auto fan setting will be complete.

The ON mark will flash during the fan operation for airflow automatic adjustment.

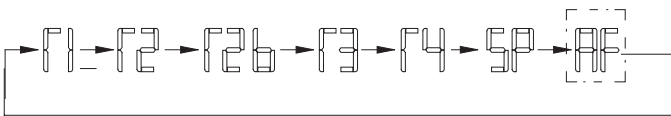

### Manual fan setting

The system can be set manually based on four static pressure settings. Each setting has a low, medium, and high speed range.

SP no.	DINSD26MB	DINSD35MB	DINSD50MB	DINSD70MB
SP0	Reserved - DO NOT USE			
SP1	0-15 Pa	0-15 Pa	0-25 Pa	0-40 Pa
SP2	15-30 Pa	15-30 Pa	25-50 Pa	40-80 Pa
SP3	30-45 Pa	30-45 Pa	50-75 Pa	80-120 Pa
SP4	45-60 Pa	45-60 Pa	75-100 Pa	120-160 Pa

When the system is off, perform the following steps using the wired controller.

1. Press the COPY button and hold for three seconds.
2. Press the + or - buttons to select the required SP option, and CONFIRM.
3. Press CONFIRM repeatedly until the desired SP number is selected.
4. To exit, allow the controller to time out, external static pressure settings is complete.

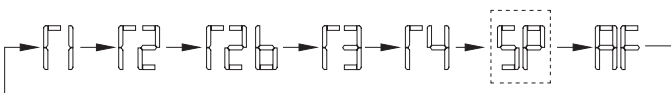

# Pro Series Indoor Cassette installation

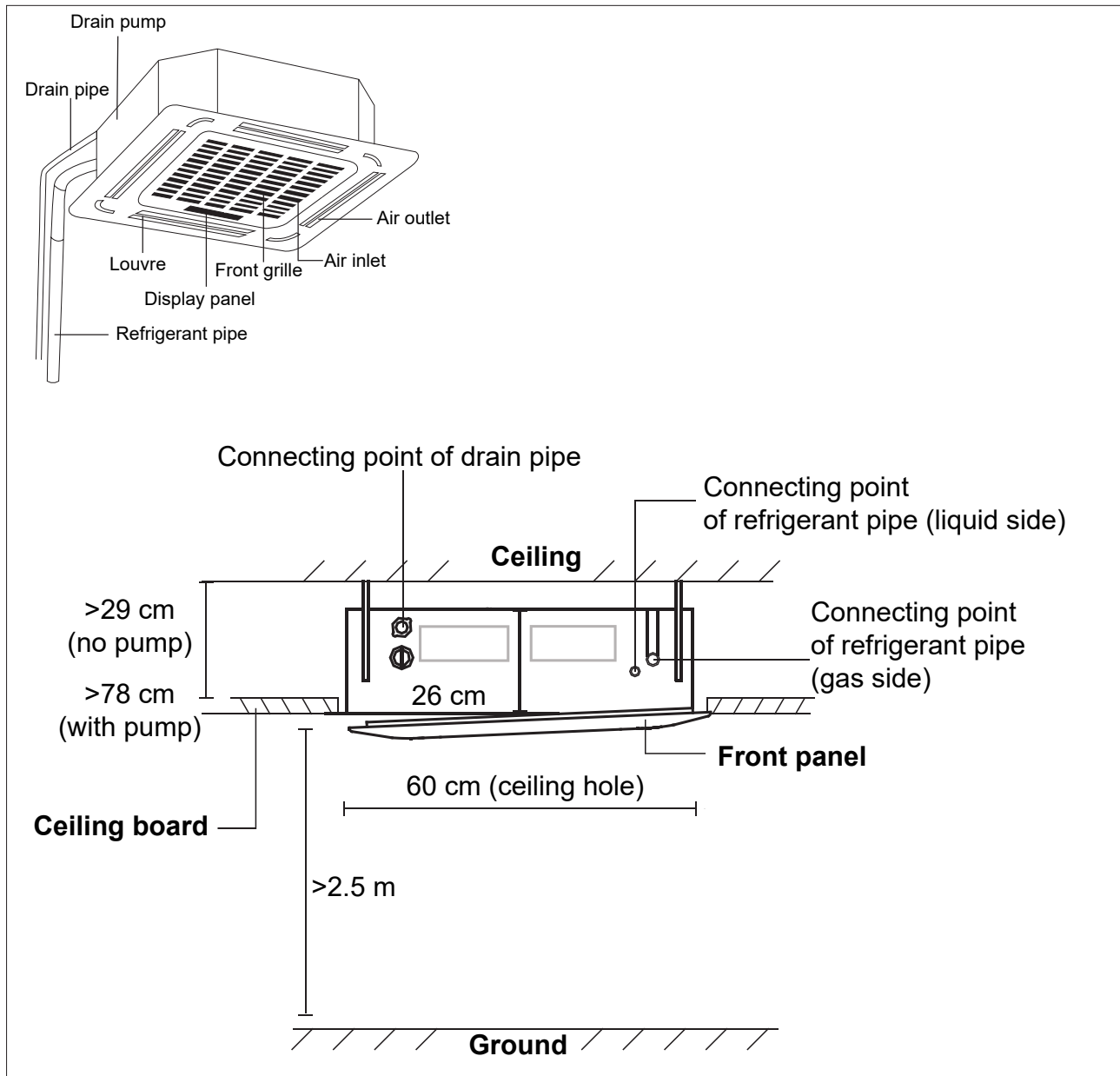

## Ensure the following:

- Good air circulation
- Enough room for installation / maintenance
- Structure can sustain weight of unit
- Convenient drainage
- Air inlet and outlet are not impeded
- Airflow adequate for room size
- No direct radiation from heaters
- Firm and solid—location will not vibrate
- At least 1 m from other electrical devices (e.g. TV) to prevent static interference

## DO NOT install:

- In rooms with high humidity such as bathrooms or laundry rooms
- In enclosed spaces
- Areas that store flammable materials or gas
- Buildings that may experience power fluctuation
- In kitchens using natural gas or LPG

## Cassette installation

### Paper template

Use the included paper template to cut a rectangular hole in the ceiling, leaving at least 1 m on all sides. The hole will be at a diameter of 60 x 60 cm. Mark the areas where the ceiling hook holes will be drilled.

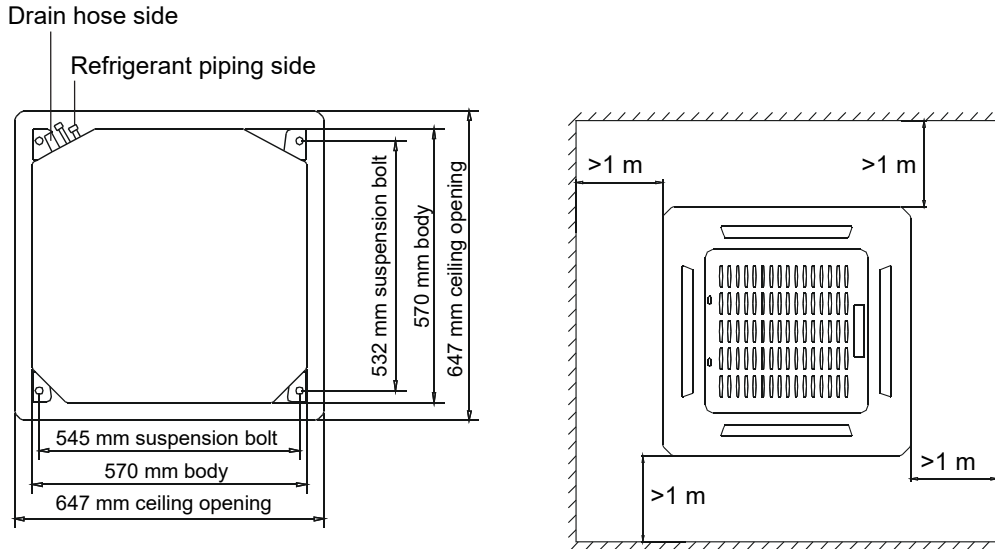

1. Drill four holes 5 cm deep at the ceiling hook positions in the internal ceiling. Hold the drill at a 90° angle to the ceiling. In new-builds the ceiling hooks can be installed in advance.
2. Using a hammer, insert the ceiling hooks into the pre-drilled holes. Secure the bolts using the washers and nuts provided.
3. Mount the indoor unit. You will need two people to lift and secure it. Insert suspension bolts into the hanging holes. Fasten them using the washers and nuts provided.

The bottom of the unit should be 24 mm higher than the ceiling board. The **L** in the diagram below should be half the length of the suspension bolt or long enough to prevent the nuts from coming off.

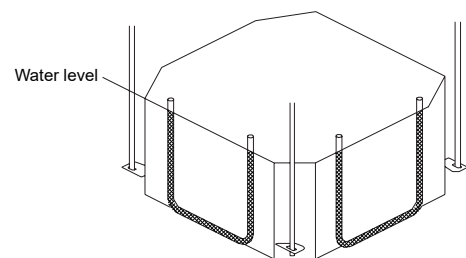
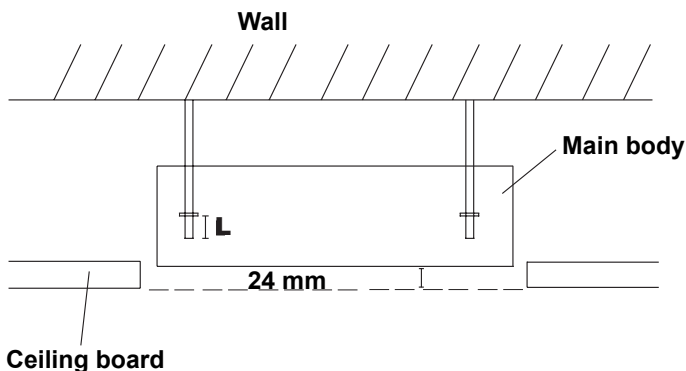
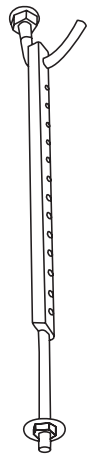

Ensure that the indoor unit is level. The unit has a built-in drain pump and float switch. If the unit is tilted against the direction of the condensate path (e.g. the drainpipe side is raised), the float switch may malfunction and cause water to leak.

## Drainpipe installation

The drainpipe is used to drain water away from the unit. Improper installation may cause unit and property damage.

- **Insulate all piping to prevent condensation which could lead to water damage.**
- If the pipe is bent or installed correctly water may leak and cause a water level switch error.
- Ensure the drain hose is placed in an appropriate area to avoid water damage and injury if the drain water has frozen.

This installation requires polyethylene tube (outside diameter 3.7-3.9 cm, inside diameter 3.2 cm).

The drainpipe information is the same as that for the slim ducted unit, refer pages 18-19.

## Wiring layout

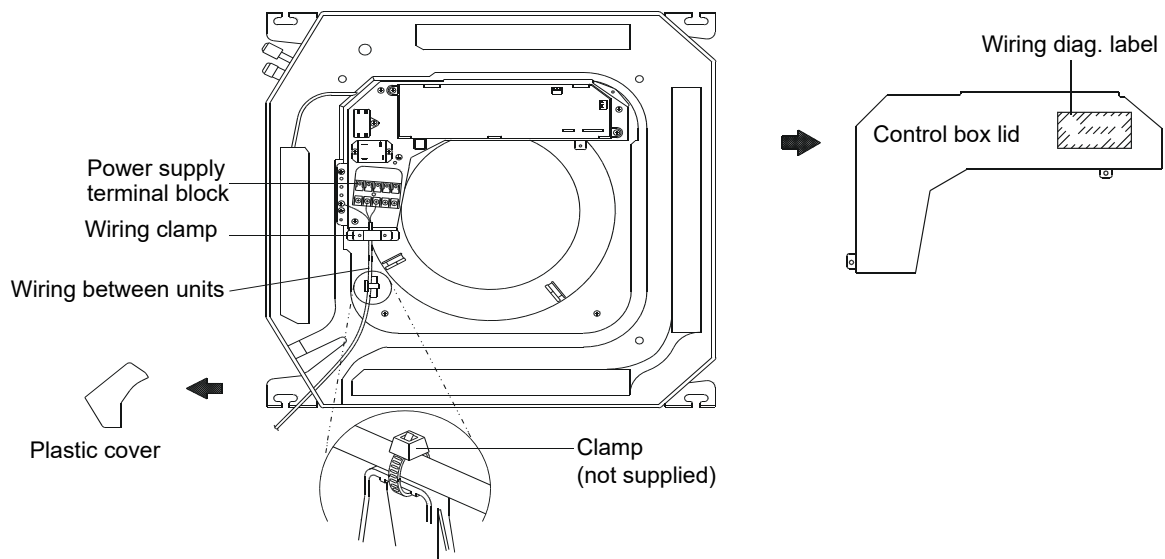

# Cassette panel installation

## Step 1: Remove the front grille

Push both of the tabs towards the middle to unlock the hook on the grille.

Hold the grille at a 45° angle, lift up and detach it from the main body.

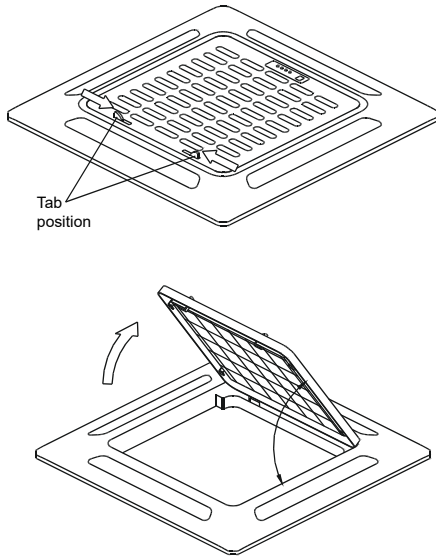

## Step 2: Install panel

Align the panel markers and attach the panel to the unit with the supplied screws. Ensure there is no space between the unit body and panel for air to enter and cause condensation and for water to drip out of the unit.

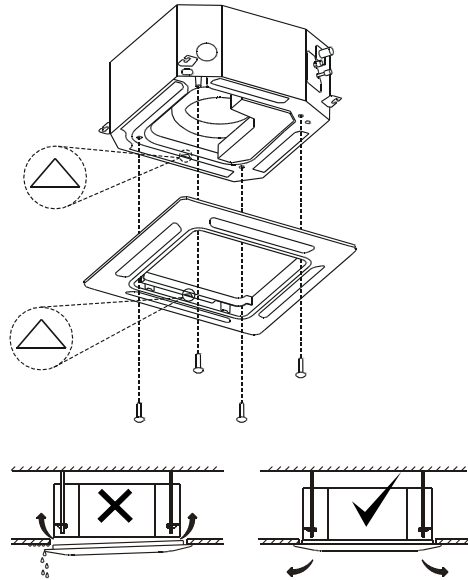

## Step 3: Mount the intake grille

Ensure the tabs at the back of the grille are properly seated in the groove of the panel.

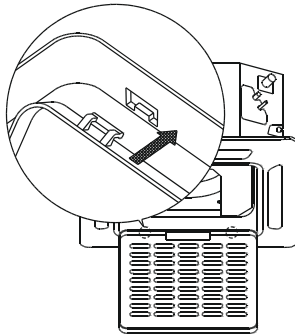

## Step 4: Connect cables

Connect the two cables of the panel to the main board of the unit.

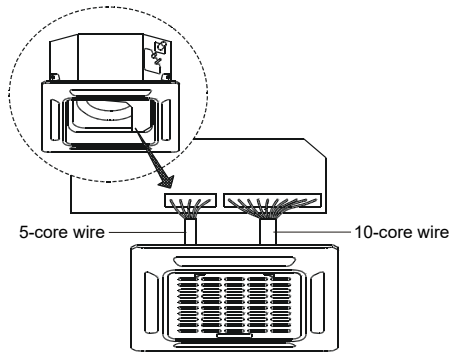

## Step 5: Secure in place

Fasten the control box lid with two screws.

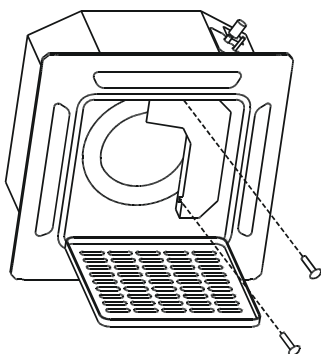

## Step 6: Close

Close the intake grille and hook in place.

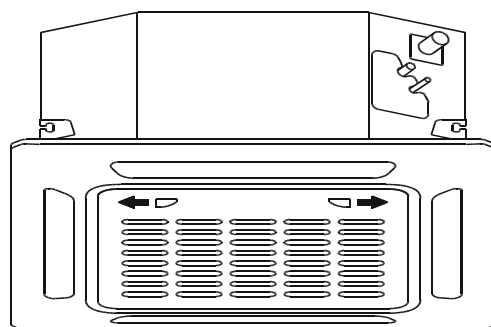



# Outdoor unit installation

## Installation summary

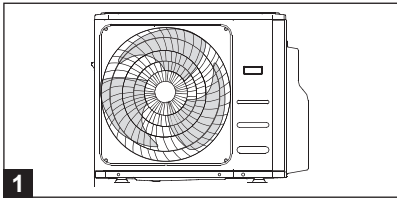

**1**  
Install the outdoor unit.

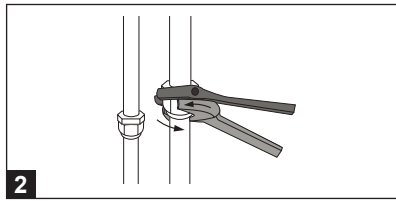

**2**  
Connect the refrigerant pipes.

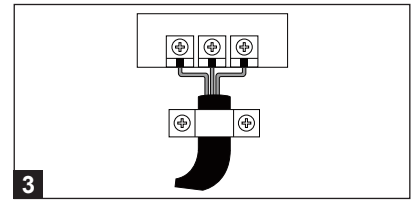

**3**  
Connect the wires.

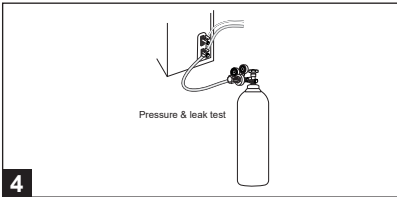

**4**  
Pressure test and leak test.

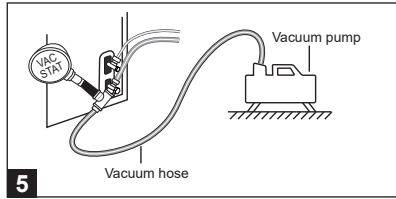

**5**  
Evacuate the system.

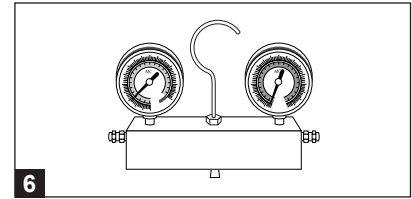

**6**  
Charge the system.

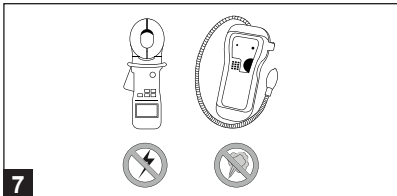

**7**  
Perform a test run.

## Clearances

The outdoor unit must be installed in accordance with the clearances outlined below. Note maintenance access, there must be sufficient room for installation and maintenance.

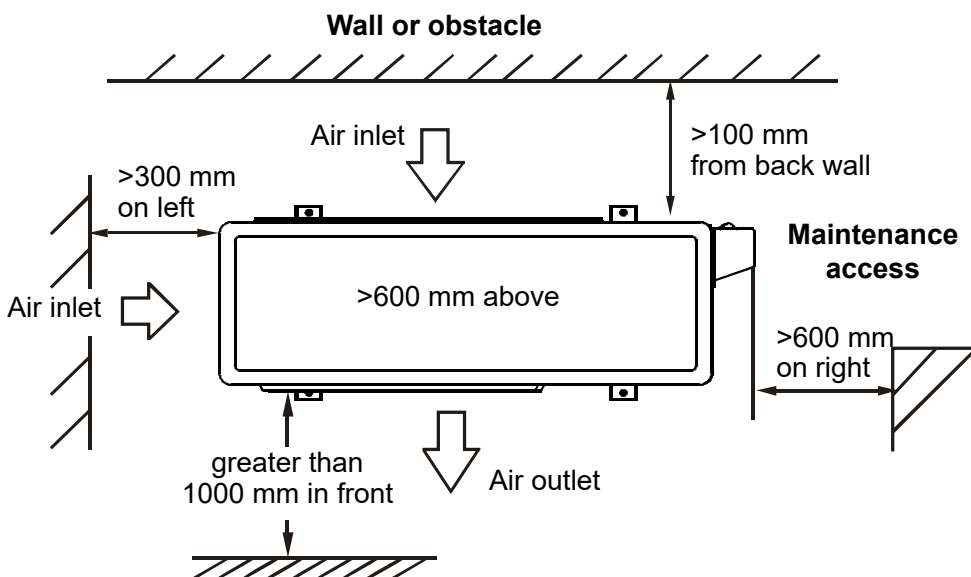

## Installation position

The outdoor unit must be located in a dry and well ventilated outdoor space on a supporting structure that is flat, horizontal, and can withstand the full operating weight of the unit. The base must be free of vibration.

Locate the outdoor unit as close as possible to the indoor unit to reduce performance losses.

Select a location where the unit will not be subject to accumulation of snow, leaves or other seasonal debris. This may negatively impact the performance and longevity of the unit. Arrange so the air outlet is not blocked or obstructed.

In addition:

- Position so as to prevent operating noise being a nuisance to others
- Away from potential fire risks or flammable materials
- If possible, away from exposure to direct sunlight as this will negatively impact cooling performance

DO NOT install in the following locations:

- Near an obstacle that will block air inlets and outlets
- Near a public street, crowded areas, or where noise will disturb others
- Near animals or plants that will be harmed by hot air discharge
- Near any source of combustible gas
- In a location that is exposed to large amounts of dust
- In a location exposed to excessive amounts of salty air

In severe environments (geothermal areas or areas with caustic gases) take precautions such as applying additional corrosion protection to exposed components.

## Special considerations for heavy wind exposure

For installations prone or exposed to strong prevailing winds such as coastal areas, please ensure the unit is sited appropriately by placing it lengthwise along the wall to reduce any negative impact on the condenser fans. Install the unit so that the air outlet fan is at a 90° angle to the direction of the wind. If needed build a barrier in front of the unit to protect it from extremely heavy winds.

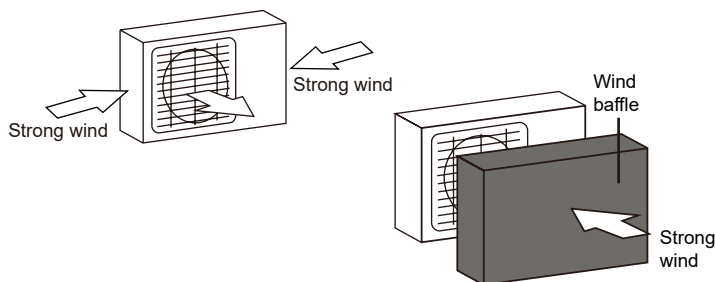

## Wall or roof mounted installations

If the outdoor unit is installed on roof structures or external walls, this may result in excessive noise and vibration. It may also be classed as a non-serviceable installation and may void warranty.

# Outdoor unit installation - mounting dimensions

Prepare the installation base of the unit according to the dimensions below.

Model	Outdoor unit W x D x H	Mounting dimensions	
		Distance A	Distance B
MON3H07B	990 x 342 x 673 mm	663 mm	354 mm
MON4H09B	1034 x 410 x 810 mm	673 mm	403 mm
MON5H11B	1034 x 410 x 810 mm	673 mm	403 mm
MON5H13B	1090 x 440 x 975 mm	615 mm	440 mm

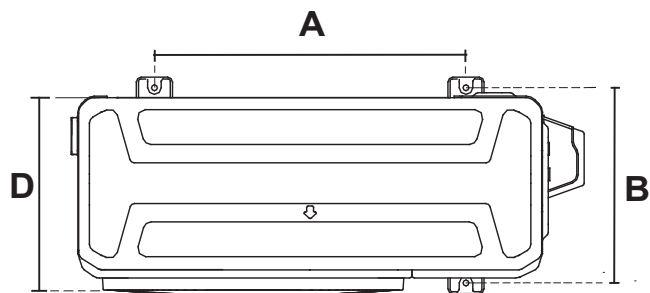
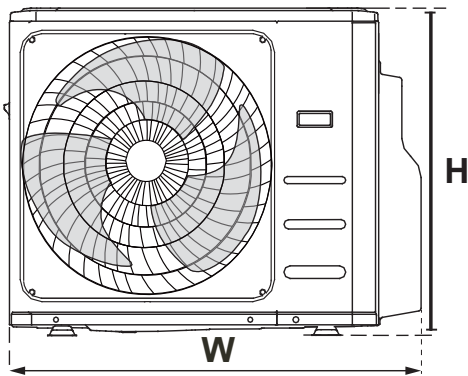

## Multiple units

	L	A
$L \leq H$	$L \leq \frac{1}{2} H$	25 cm or more
	$\frac{1}{2} H < L \leq H$	30 cm or more
$L > H$	Cannot be installed	

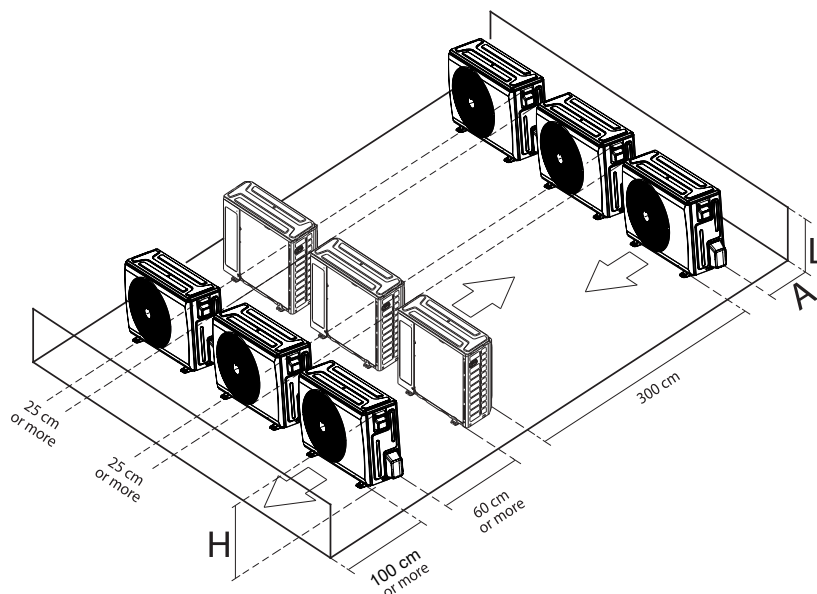

# Outdoor unit - drain joint and anchoring

## Installing the drain joint

Before bolting the outdoor unit in place, install the drain joint at the bottom of the unit. There are two different types of drain joint depending on the outdoor model.

### If the drain joint comes with a rubber seal

1. Fit the rubber seal on the end of the drain joint that will connect to the outdoor unit.
2. Insert the drain joint into the hole in the base pan of the unit.
3. Rotate the drain joint 90° until it clicks in place facing the front of the unit.
4. Connect a drain hose extension (not included) to the drain joint to redirect the water from the unit during heating mode.

### If the drain joint doesn't come with a rubber seal

1. Insert the drain joint into the hole in the base pan of the unit, it will click into place.
2. Connect a drain hose extension (not supplied) to the drain joint to redirect water from the unit during heating mode.

In cold climates, make sure the drain hose is as vertical as possible to ensure quick water drainage. If the water drains too slowly, it can freeze in the hose and flood the unit. Insulating the drain hose in cold climates is recommended.

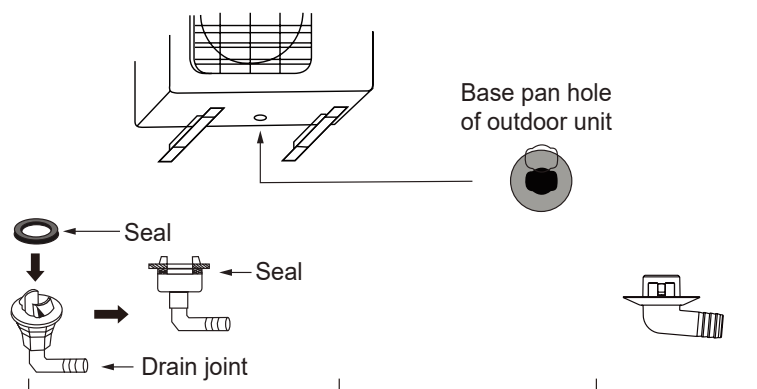

## Anchoring the outdoor unit

The outdoor unit can be anchored to the ground or to a wall mounted bracket with bolts (M10). Prepare the installation base of the unit according to the dimensions on the previous page.

To reduce the transmission of vibration and noise, a waffle pad or something similar shall be installed beneath the unit at each anchor point.

# Refrigerant piping connection



Avoid direct contact with bare pipes as this may result in burns or frostbite.

When connecting refrigerant piping do not let substances or gases other than the specified refrigerant enter the unit. The presence of other gases or substances will lower the unit's capacity, and can cause abnormally high pressure in the refrigeration cycle. This could cause an explosion.

The branching pipe must be installed horizontally. An angle of more than 10° may cause malfunction. Insulate the gas and liquid piping to prevent condensation.

DO NOT install the connecting pipe until both the indoor and outdoor units have been installed.

## Pipe length

Ensure the length of the refrigerant pipe, the number of bends, and the drop height between the indoor and outdoor units meets the requirements shown on the specification summary page.

## Step 1: Cut pipes

When preparing refrigerant pipes, take extra care to cut and flare them properly. This will ensure efficient operation and minimise the need for future maintenance. Be careful not to damage, dent, or deform the pipe while cutting. This will drastically reduce the heating efficiency of the unit.

- Measure the distance between the indoor and outdoor units.
- Using a pipe cutter, cut the pipe a little longer than the measured distance.
- Make sure that the pipe is cut perfectly at a 90° angle.

## Step 2: Remove burrs

Burrs affect the airtight seal of the refrigerant piping connection. They must be completely removed. Hold the pipe at a downward angle to prevent burrs from falling into the pipe. Using a reamer or deburring tool, remove all burrs from the cut section of the pipe.

## Step 3: Flare pipe ends

Proper flaring is essential to achieve an airtight seal. After removing burrs from the cut pipe, seal the ends with PVC tape to prevent foreign materials from entering the pipe. Sheath the pipe with insulating material.

Place the flare nuts on both ends of the pipe. Make sure they are facing in the right direction, as you can't put them on or change direction after flaring.

Remove PVC tape from the ends of the pipe when ready to perform flaring work. Clamp flare form on the end of the pipe. The end of the pipe must extend beyond the flare form.

Place flaring tool onto the form. Turn the handle of the flaring tool clockwise until the pipe is fully flared. Flare pipe in accordance with the dimensions in the table on the next page, then remove the flaring tool and flare form. Inspect the end of the pipe for cracks and even flaring.

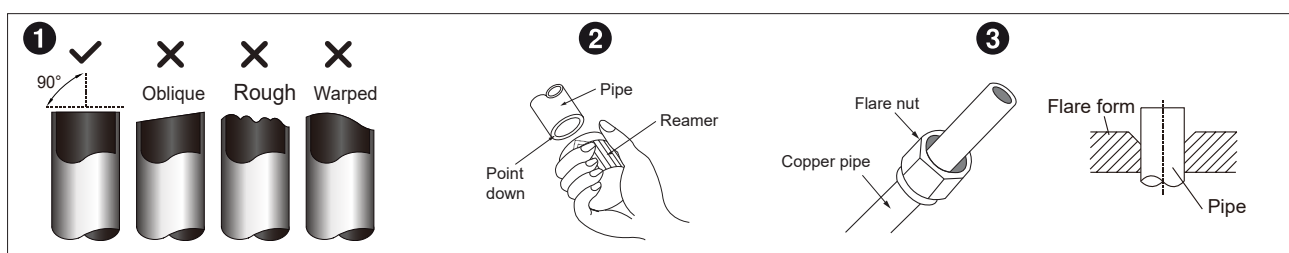

#### Step 4: Connect pipes

Connect the copper pipes to the indoor unit first, then connect to the outdoor unit. Connect the low pressure pipe, then the high pressure pipe.

When connecting the flare nuts, apply a thin coat of compatible refrigeration oil to the flared ends of the pipes. Align the centre of the two pipes that will be connected. Tighten the flare nut as tightly as possible by hand. Using a spanner, grip the nut and use a torque wrench to tighten the flare nut according to the torque values in the table above.

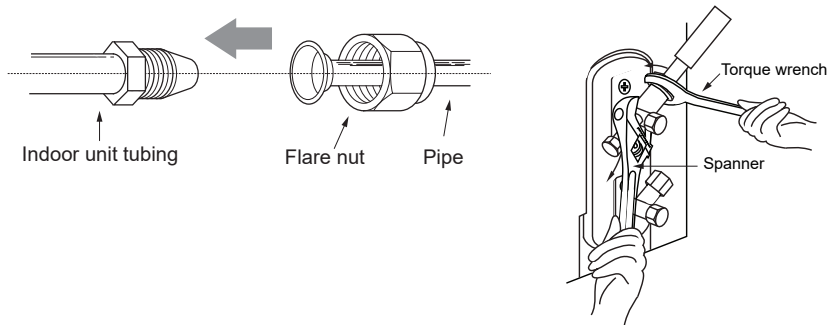

Carefully bend the tubing in the middle. DO NOT bend the tubing more than 90°, or more than three times.

After connecting the copper pipes to the indoor unit, wrap the power cable, signal cable, and then the piping together with the binding signal tape. DO NOT intertwine or cross the signal cable with other wires, while bundling these items together.

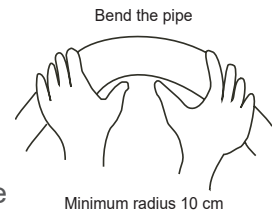

Make sure the pipe is connected correctly. Overtightening may damage the bell mouth and under tightening may lead to leakage.



#### Please note:

- Pipe run must be supported every 2 m
- R32 flammable refrigerant labels must be placed on the pipe every 2 m
- Insulate all the piping, including the valves of the outdoor unit.

# Wiring



Before performing any electrical or wiring work, turn off the mains power to the system.

- If the unit has an auxiliary electric heater, it **MUST** be installed at least 1 m away from combustible materials.
- To avoid getting an electric shock, **NEVER** touch the electrical components immediately after the power supply has been turned off. After turning off the power, always wait ten minutes or more before you touch any electrical components.
- Ensure that you **DO NOT** cross your electrical wiring with your signal wiring. This may cause distortion and interference.
- The unit **MUST** be connected to the main outlet. Normally, the power supply must have a impedance of 32 ohms.
- No other equipment should be connected to the same power circuit.
- Connect the outdoor wires before connecting the indoor wires.

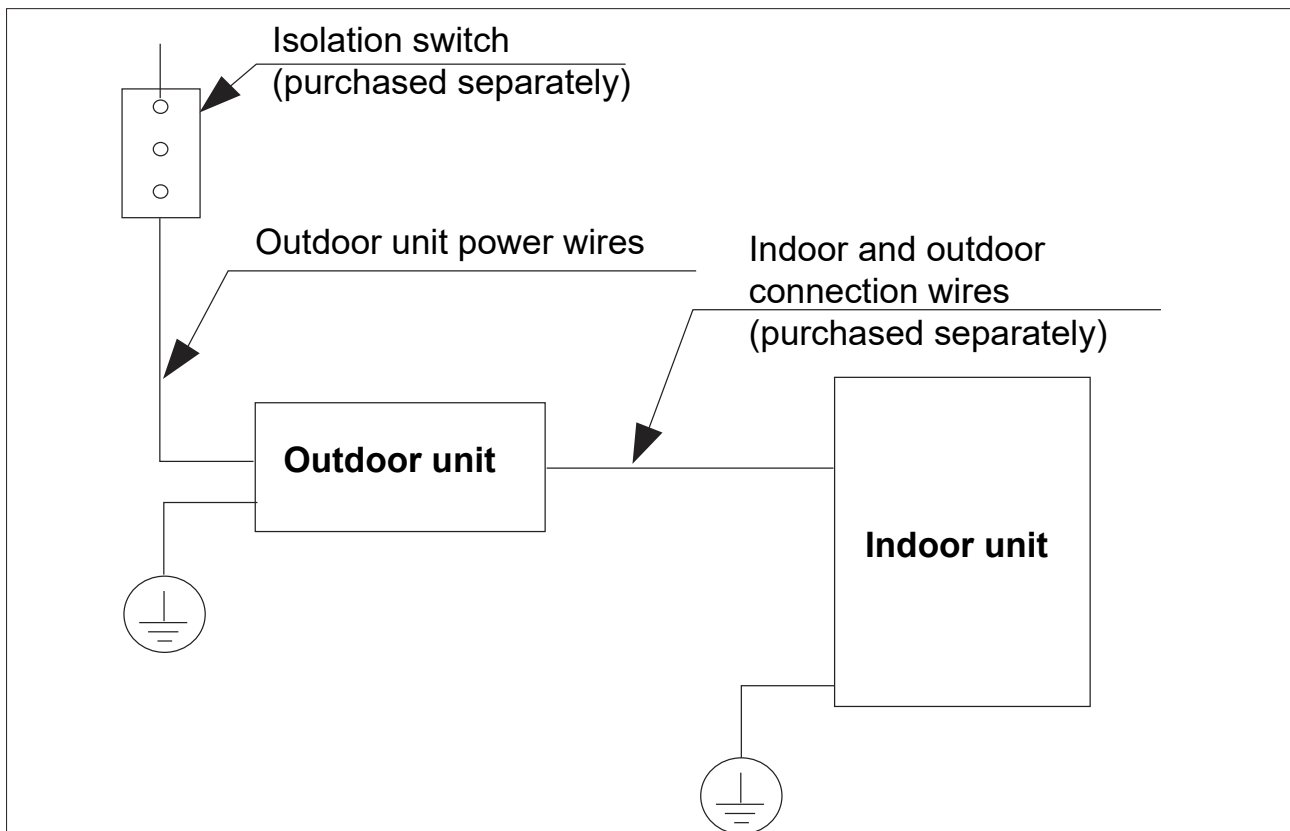

# Outdoor unit wiring

Prepare the cable for connection using the below table as reference. When connecting the wires, strictly follow the wiring diagram found inside the electrical box cover.

Rated current of appliance	Nominal cross-sectional area (mm <sup>2</sup> )
>3 and ≤6 A	0.75 mm <sup>2</sup>
>6 and ≤10 A	1 mm <sup>2</sup>
>10 and ≤16 A	1.5 mm <sup>2</sup>
>16 and ≤25 A	2.5 mm <sup>2</sup>
>25 and ≤32 A	4 mm <sup>2</sup>
>32 and ≤40 A	6 mm <sup>2</sup>

## Choose the right cable size

The size of the power supply cable, signal cable, fuse, and switch needed is determined by the maximum current of the unit. The maximum current is indicated on the data plate located on the side panel of the unit. Refer to this data plate to choose the right cable, fuse, or switch.

Using wire strippers, strip the rubber jacket from both ends of the signal cable to reveal approximately 15 cm of wire.

Strip the insulation from the ends, and using a wire crimper, crimp u-lugs on the ends.

## Connection

1. To access the electrical control box remove the five screws from the side cover.
2. Connect the u-lugs to the terminals. Match the wire colours / labels with the labels on the terminal block. Firmly screw the u-lug of each wire to its corresponding terminal.
3. Clamp down the cable with the cable clamp.
4. Insulate unused wires with electrical tape. Keep them away from any electrical or metal parts.
5. Reinstall the cover of the electrical control box.

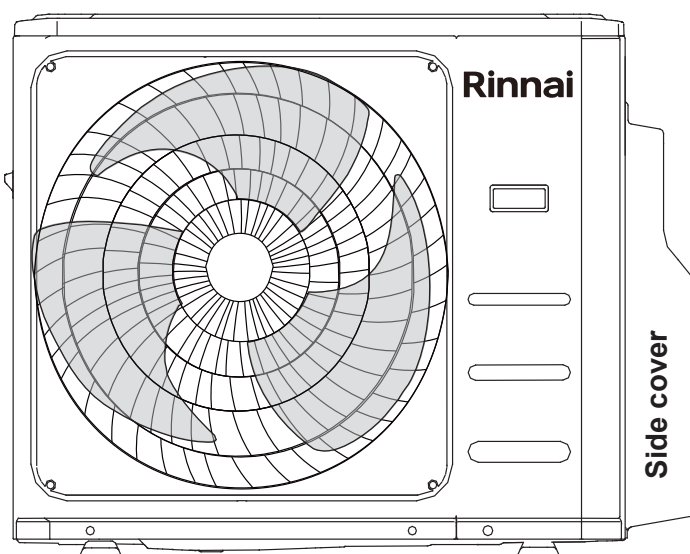



# Outdoor unit wiring diagrams



Before accessing the electrical terminals, disconnect all power from the system.

An individual power circuit must be used for this system. Wiring shall be conducted in accordance with the unit's wiring diagram.

The screws which fasten the wiring within the electrical switchboard may come loose from vibration in transportation. Please ensure that all electrical connections within the unit are sufficiently tightened. Loose connections may cause overheating at the terminals, leading to an electrical failure or malfunction.

Confirm the suitability of the power source.

Confirm that the electrical capacity is sufficient for the operating current of the system. Ensure that the starting voltage is maintained at more than 90% of the rated voltage marked on the data plate.

Confirm the cable thickness is suitable for the power source specification.

Always use an adequately sized circuit breaker.

## Compressor / power supply information

Compressor start/stop	Stop time	Min. 3 minutes
Power supply voltage	Voltage variance	Within +/- 10% of supply voltage
	Voltage drop	Within +/- 15% of supply voltage
	Voltage imbalance	Within +/- 3% of supply voltage

# Outdoor MON3H07B (16022000035910)

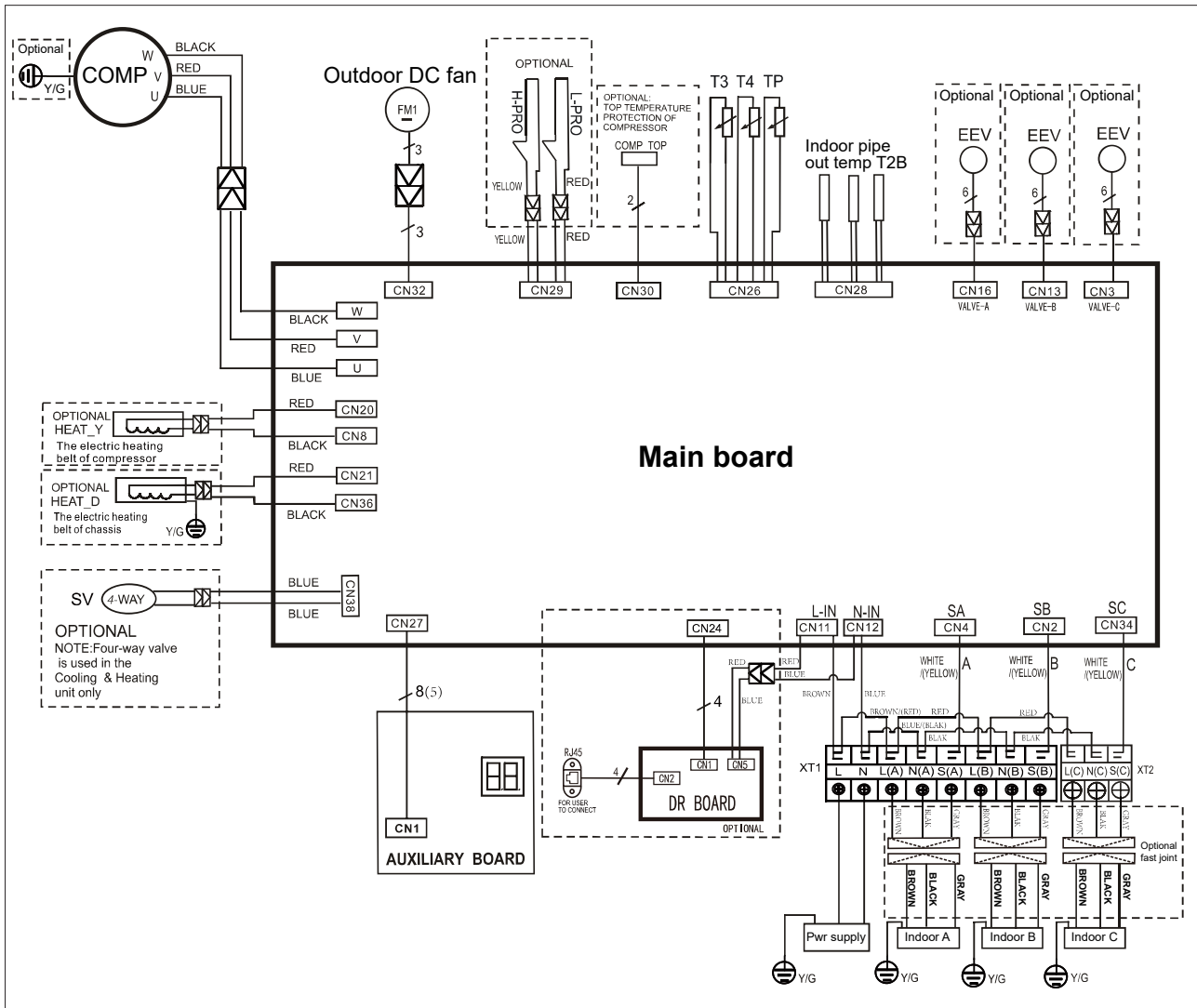

Abbrev.	Description
4-way	Gas valve assembly / 4-way valve
AC-Fan	Alternating current fan
DC-Fan	Direct current fan
CT1	AC current detector
COMP	Compressor
L-Pro	Low pressure switch
H-Pro	High pressure switch
EEV	Electronic expansion valve
Heat_D	Chassis heater
Heat_Y	Crankcase heater
SV	4-way valve
T2B	Indoor HEX exhaust coil temperature sensor
T3	Coil temperature sensor
T4	Outdoor ambient temperature sensor
TP	Compressor discharge temperature sensor
TH	Heatsink temperature sensor
COMP TOP	Compressor top temperature sensor

# Outdoor MON4H09B (16022300000803)

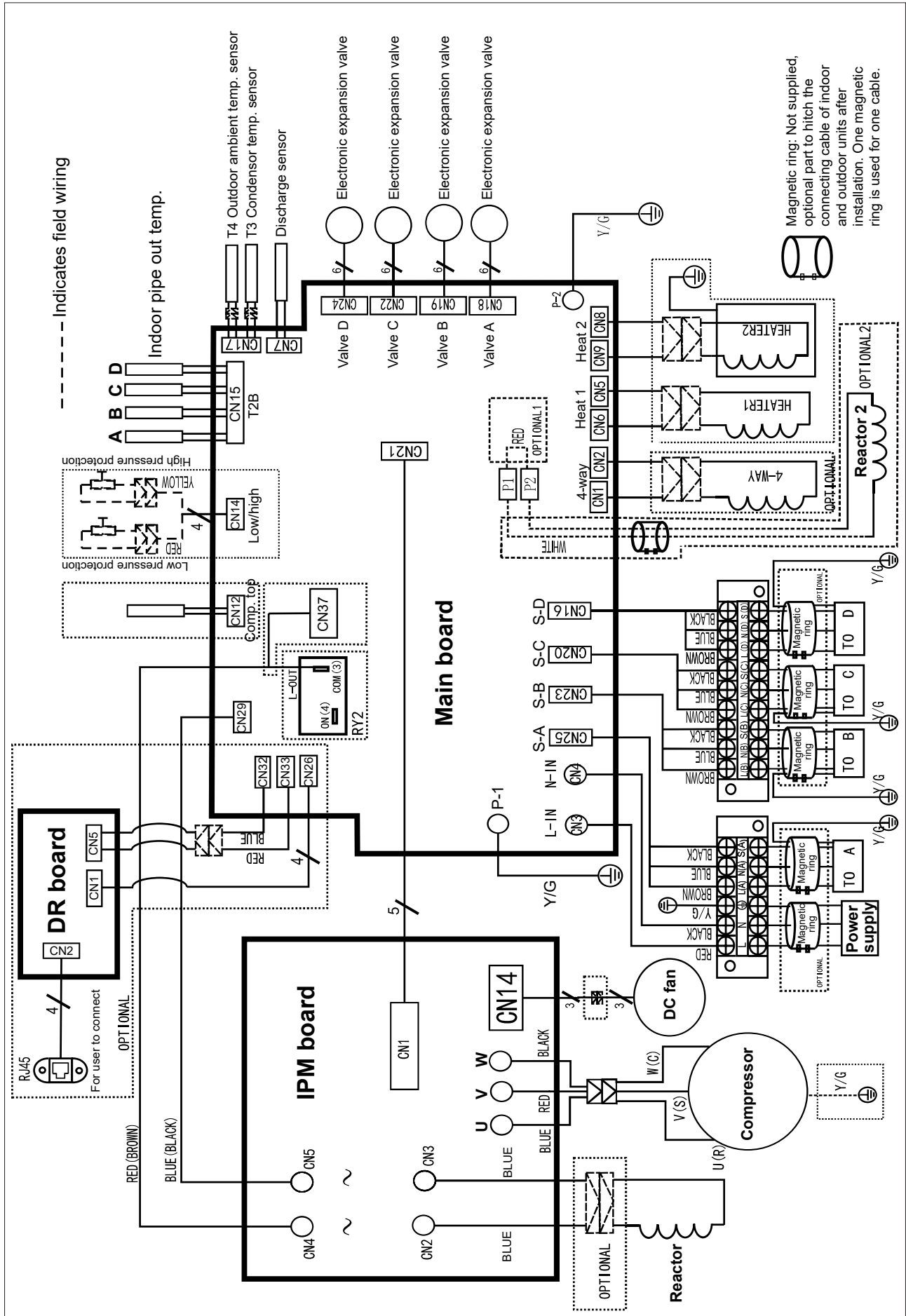

# Outdoor MON5H11B (16022300000795)

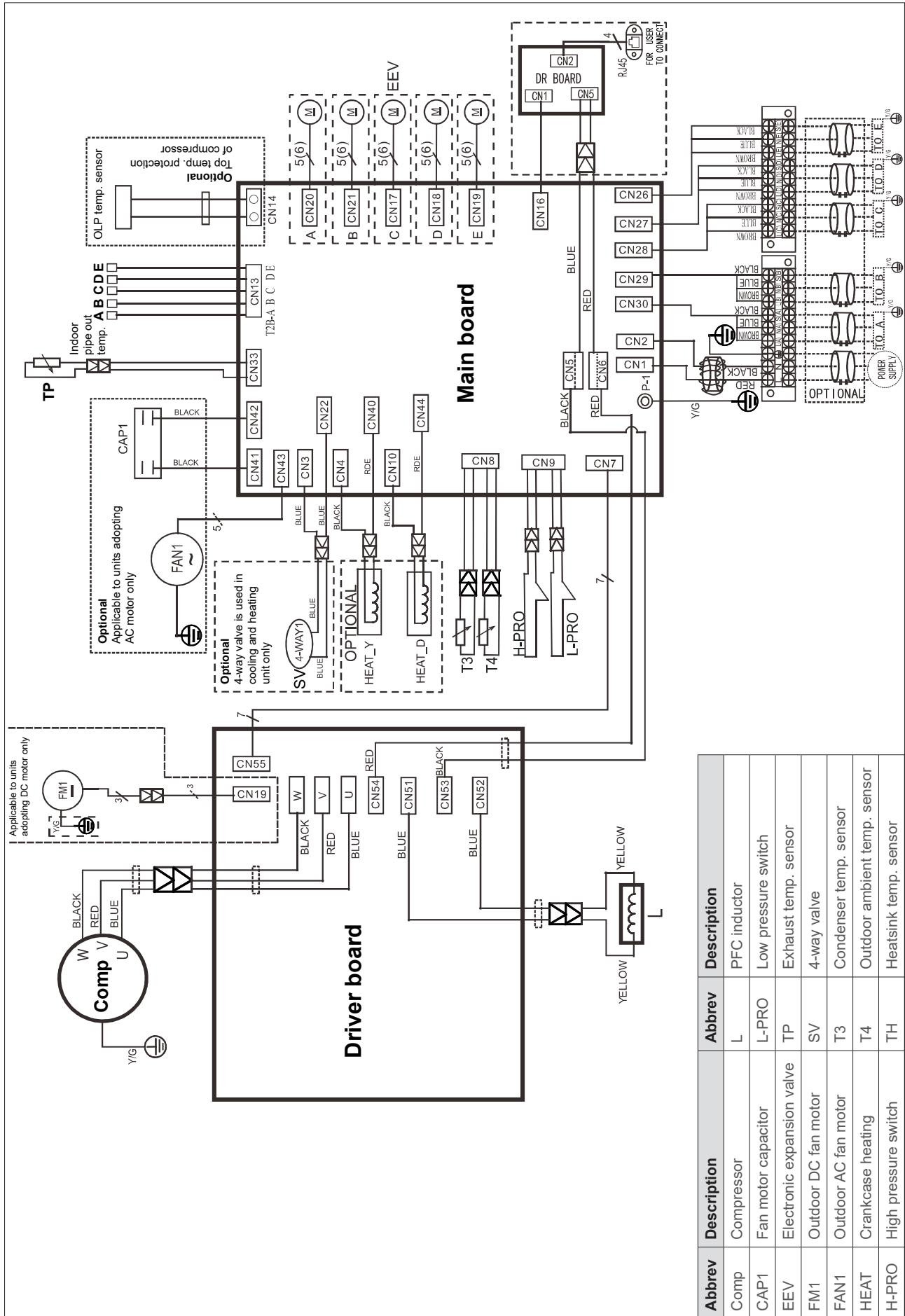

# Outdoor MON5H13B (16022300005423)

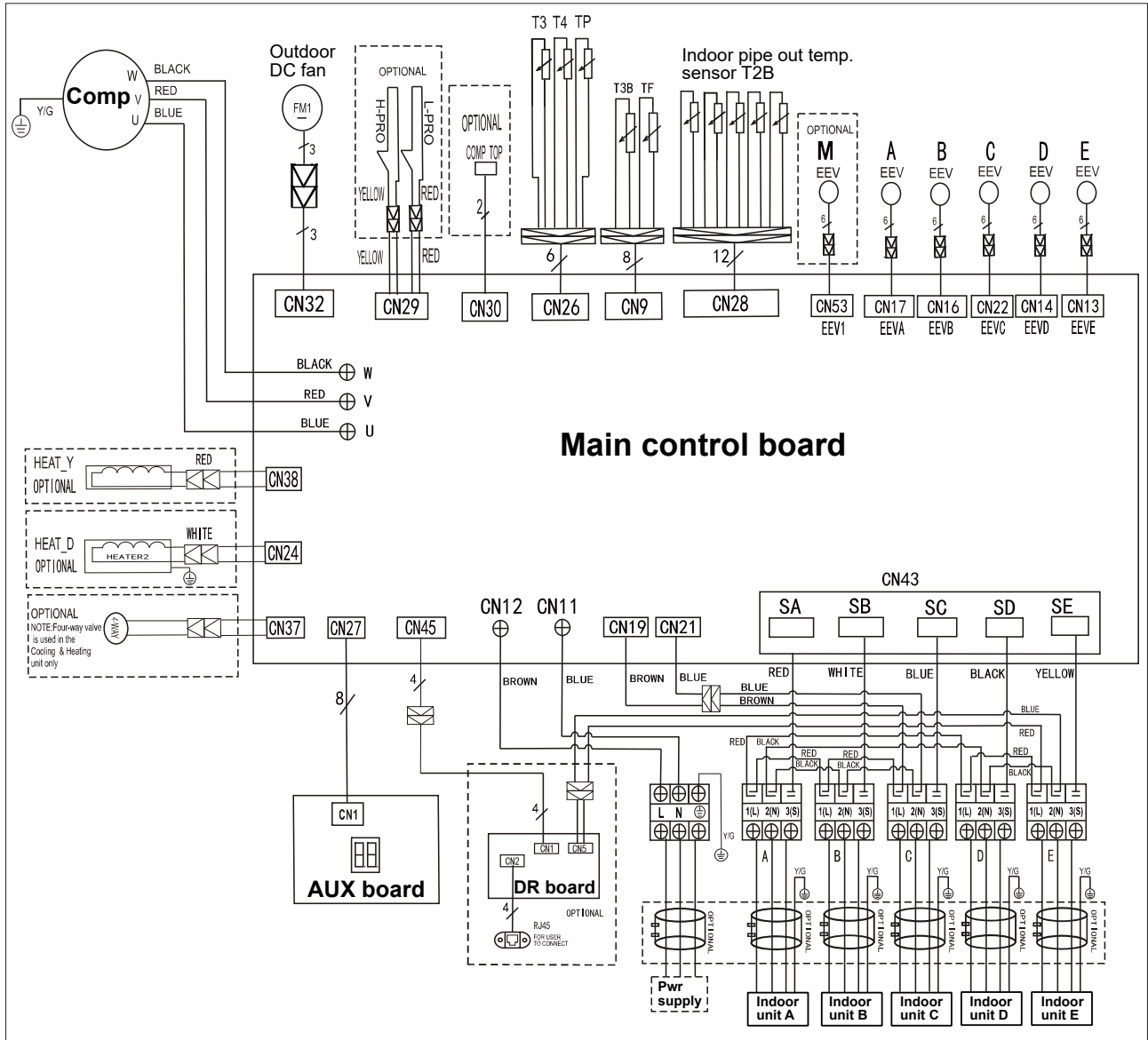

Abbrev	Description	Abbrev	Description
Comp	Compressor	L-PRO	Low pressure switch
EEV	Electronic expansion valve	SV	Reversing valve
FM1	Outdoor DC fan motor	TP	Compressor discharge temp. sensor
HEAT_D	Chassis heater	T3	Coil temp. sensor
HEAT_Y	Crankcase heater	T4	Outdoor ambient temp. sensor
H-PRO	High pressure switch	COMP TOP	Compressor top OLP temp. sensor

# Air evacuation

Any foreign matter in the refrigerant circuit can cause abnormal rises in pressure, which can cause damage to the unit, reduce its efficiency, and cause injury. Use a vacuum pump and manifold gauge to evacuate the refrigerant circuit, removing non-condensable gas and moisture from the system.

Evacuation should be performed upon installation.

Before performing evacuation:

- ☑ Make sure the connective pipes between the indoor and outdoor units are connected properly.
- ☑ Make sure all the wiring is connected.
- ☑ Read relevant manifold and vacuum pump instructions to ensure correct use.

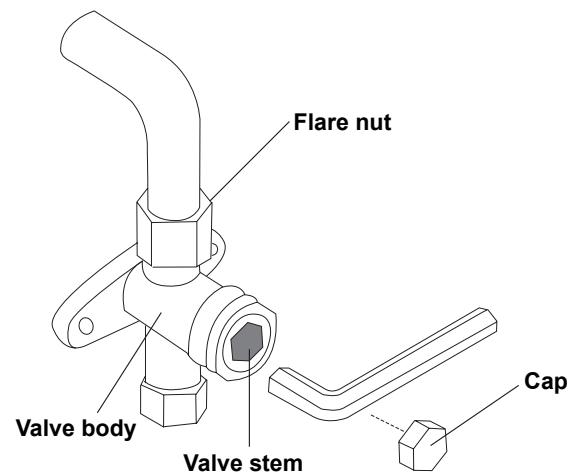
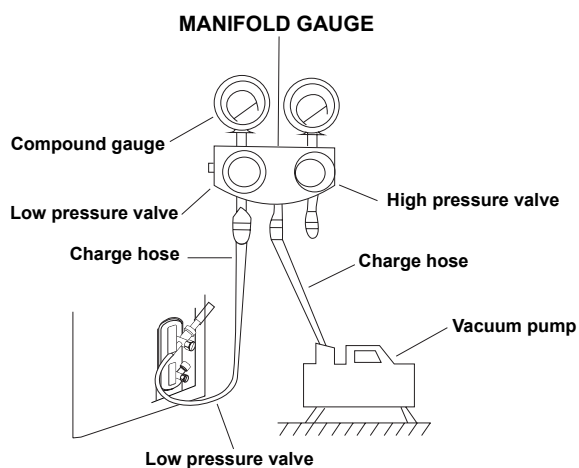

1. Connect the charge hose to the service port of the outdoor unit's low pressure valve.
2. Connect the charge hose to the vacuum pump.
3. Open the low pressure side of the manifold gauge. Keep the high pressure side closed.
4. Turn on the vacuum pump to evacuate the system and run for at least 30 minutes, or until the compound gauge reads 100 kPa.
5. Close the low pressure valve and turn off the vacuum pump. Wait for five minutes then check there has been no change in system pressure (a change may indicate a gas leak).
6. If no change in system pressure, unscrew cap from high pressure valve. Insert hexagonal wrench and open the valve by turning the wrench anticlockwise. Listen for gas to exit the system, then close the valve after approximately five seconds.
7. Watch the pressure gauge for one minute to make sure there is no change in pressure. It should read slightly higher than atmospheric pressure.
8. Remove the charge hose from the service port, and using a hexagonal wrench, fully open the low and high pressure valves. When opening turn the wrench until it hits against the stopper. **DO NOT** force the valves to open further.
9. Allow the refrigerant to flow throughout the system, ensure there are no leaks. If the service valve spindles are leaking, front and back seat them several times to re-adjust the seal behind the valve stem. Apply Nylog leak lock onto the threaded fittings before the valve caps are placed back on.
10. Tighten caps by hand, then tighten with a tool.
11. Ensure system is leak tested again to ensure no gas leaks.

# Adding refrigerant

Refrigerant charging must be performed after wiring, vacuuming, and leak testing.

DO NOT exceed the maximum allowable quantity of refrigerant or overcharge the system. Doing so can damage the unit or impact the way it functions.

Charging with unsuitable substances may cause explosions or accidents. Ensure that the appropriate refrigerant is used. DO NOT mix refrigerant types.

Make sure the conditions within the area have been made safe by controlling the flammable material when refrigerant is added into the unit.

Depending on the length of connective piping or the pressure of the evacuated system, refrigerant may need to be added, refer table below.

N = 3, three head models

N = 4, four head models

N = 5, five head models

Additional refrigerant per pipe length			
Connective pipe length (m)	Air purging method	Additional refrigerant (R32)	
Less than std. pipe length x N	Vacuum pump	N/A	
More than std. pipe length x N	Vacuum pump	Liq. side: Ø6.35 mm (Total pipe length - pre-charge pipe length x N) x 15 g/m	Liq. side: Ø9.52 mm (Total pipe length - pre-charge pipe length x N) x 30 g/m

Remove additional charge according to the rated volume (5 m refrigerant piping) when doing verification test.

The standard pipe length is 10 m.

# Safety and leakage test

## Electrical safety check

Perform electrical safety check after completing the installation. Check the following:

### 1. Insulated resistance

The insulated resistance must be more than 2 MΩ.

### 2. Earthing work

After finishing earthing work, measure the earthing resistance by visual detection and using the earthing resistance tester. Make sure the earthing resistance is less than 4 Ω.

### 3. Electrical leakage test (performed when unit in on)

During test operation use a multimeter to perform an electrical leakage check. Turn off the unit immediately if leakage occurs, troubleshoot and rectify until the unit performs correctly.

## Gas leak check

### Soapy water method

Apply a soap-water solution or liquid detergent on the indoor or outdoor unit connections with a soft brush to check for gas leaks at the connection points of the piping. If bubbles emerge there are leaks.

### Leak detector

Use a leak detector to check for leaks.

### Connection points

The below diagram is for illustration only, the actual order, depending on model, may vary.

4 head model - A, B, C, D

5 head model - A, B, C, D, E

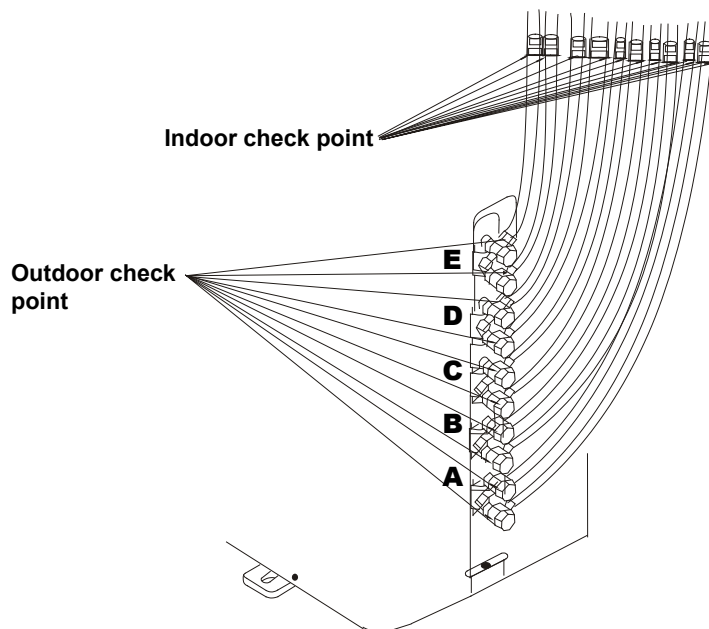



# Test run

## Before the test run

The test run must be performed after the entire system has been installed. Failure to perform the test run may result in unit damage, property damage, or personal injury. Confirm the following before performing the test.

- ✓ Indoor and outdoor units are properly installed
- ✓ Piping and wiring are properly connected
- ✓ No obstacles near the inlet / outlet of the unit that might cause performance or product malfunction
- ✓ Refrigeration system does not leak
- ✓ Drainage system is unimpeded and draining to a safe location
- ✓ Insulation is properly installed
- ✓ Earthing wires are properly connected
- ✓ Length of the piping and additional refrigerant stow capacity have been recorded
- ✓ Power voltage is the correct voltage for the air conditioner

## Test run instruction

1. Ensure the liquid and gas stop valves are open.
2. Turn on the main power switch and allow the unit to warm up.
3. Set the unit to COOL mode.
4. For the indoor unit:
  - Ensure controller works properly
  - If applicable, louvres work properly
  - Double check room temperature is being registered correctly
  - If applicable, indicators on remote control and the display panel operate correctly
  - If applicable, manual buttons on the indoor unit work correctly
  - That the drainage system is unimpeded and draining smoothly
  - That there is no vibration or abnormal noise during operation
5. For the outdoor unit:
  - System does not have any gas leaks
  - There is no vibration or abnormal noise during operation
  - Unit operation does not disturb neighbouring properties or pose a safety hazard

# Automatic correction function

## Automatic wiring / piping correction function

Models now have a feature for automatic correction of wiring / piping errors. Press the 'Check' switch on the outdoor unit PCB board for five seconds until the LED displays 'CE', indicating that this function is working. Approximately 5-10 minutes after the switch is pressed, the 'CE' disappears, meaning that the wiring / piping error is corrected and all the wiring / piping is properly connected.

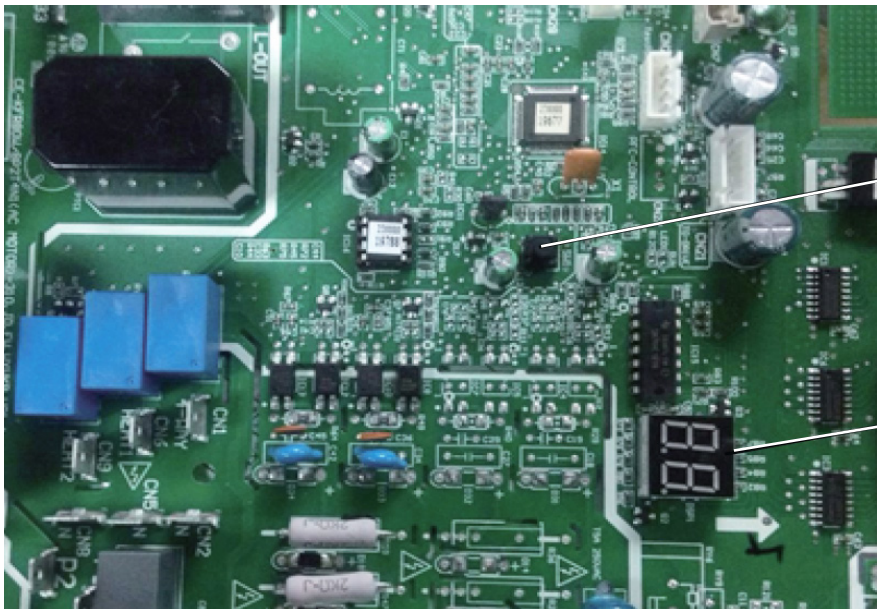

Correct

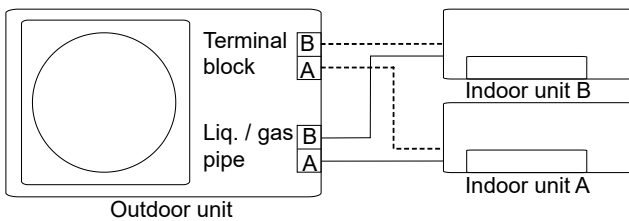

Incorrect wiring

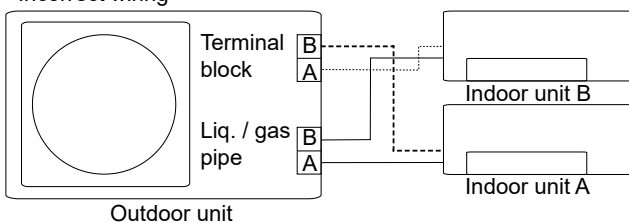

Incorrect wiring

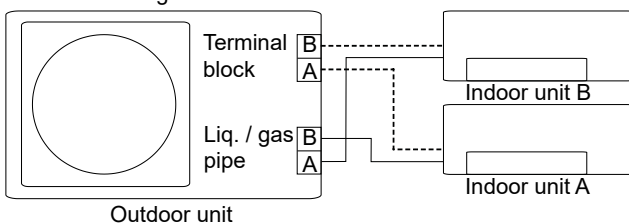

## How to activate this function

1. Make sure outdoor temperature is above 5 °C.
2. Check that the stop valves of the liquid and gas pipes are open.
3. Turn on the breaker and wait at least two minutes.
4. Press the check switch on the outdoor PCB board until the LED shows 'CE'.

# Commissioning

## Pre-start up

- Verify all packaging material has been removed from the unit
- Remove all shipping hold down bolts and brackets
- Check the condensate connection is installed, as per installation instructions
- Check all electrical connections and terminals for tightness
- Check that the indoor return air filter is clean and in place
- Verify that the unit installation is level
- Check fans for alignment and noise

## Operation check

Run the system for at least 20 minutes and record the following:

Suction pressure	kPa
Suction line pressure	°C
Discharge pressure	kPa
Liquid line temperature	°C
Superheat	K
Sub-cooling	K
Compressor Amps (L1)	A
Compressor Amps (L2 for 3 phase)	A
Indoor coil air on (return) temp.	°C DB
Indoor coil air on (supply) temp.	°C DB
Outdoor ambient air temp.	°C DB
Length of liquid line	m
Length of suction line	m
Liquid line diameter	mm
Suction line diameter	mm
Extra refrigerant quantity charged (if applicable)	kg
Supply voltage	V
Actual voltage	V

## Error codes: Slim Ducted

Malfunction	RUN	Timer	DEF	Alarm	Error
Open or short circuit of T1 temperature sensor	☀	X	X	X	E0
Open or short circuit of T2 temperature sensor	X	X	☀	X	E1
Indoor / outdoor unit communication error	X	☀	X	X	E2
Full water malfunction	X	X	X	☀	E3
Indoor EEPROM malfunction	☀	☀	X	X	E4
IPM module protection	☀	O	X	X	E5
Open or short circuit of T3 / T4 temp. sensor or outdoor EEPROM error	☀	O	X	X	E6
Outdoor fan speed out of spec	☀	O	☀	X	E7
Indoor fan speed out of spec	☀	O	O	X	F5
Voltage protection	☀	O	X	O	PO
Outdoor unit overcurrent protection	☀	☀	☀	X	P2
Inverter compressor drive protection	☀	■	X	X	P4
Mode conflict	☀	X	O	O	P5
O = on X = off ☀ = flash at 2 Hz ■ = flash at 0.5 Hz					

## Error codes: High Wall and Cassette

Malfunction	Error	Timer lamp	Lamp (flashes)
Indoor EEPROM malfunction	E0	X	1
Communication error between indoor and outdoor unit	E1	X	2
Indoor fan speed out of specification	E3	X	4
Open or short circuit of T1 temperature sensor	E4	X	5
Open or short circuit of T2 temperature sensor	E5	X	6
Water level alarm	EE	X	8
Overcurrent protection	F0	O	1
Open or short circuit of T4 temperature sensor	F1	O	2
Open or short circuit of T3 temperature sensor	F2	O	3
Open or short circuit of T5 temperature sensor	F3	O	4
Outdoor EEPROM malfunction	F4	O	5
Outdoor fan speed out of specification	F5	O	6
Open or short circuit of T2B temp. sensor	F6	O	7
Communication error between auto-lifting panel on cassette (N/A for NZ models)	F7	O	8
Auto-lifting panel is faulty (N/A for NZ models)	F8	O	9
Auto-lifting panel is not closed (N/A for NZ models)	F9	O	10
IPM module malfunction	P0	☀	1
Over voltage or low voltage protection	P1	☀	2
Ambient temperature protection-too low	P3	☀	4
Error rotor position protection of compressor	P4	☀	5
Mode conflict	P5	☀	6
Low pressure protection of compressor	P6	☀	7
O = on X = off ☀ = flash at 2 Hz			

# Error codes: Outdoor unit

Error	LED status
E0	Outdoor EEPROM malfunction
E2	Indoor / outdoor unit communication error
E3	Communication error between IPM board and outdoor main board
E4	Open or short circuit of outdoor unit temperature sensor
E8	Outdoor fan speed out of specification
F1	Number A indoor unit coil outlet temperature sensor or sensor connector is faulty
F2	Number B indoor unit coil outlet temperature sensor or sensor connector is faulty
F3	Number C indoor unit coil outlet temperature sensor or sensor connector is faulty
F4	Number D indoor unit coil outlet temperature sensor or sensor connector is faulty
F5	Number E indoor unit coil outlet temperature sensor or sensor connector is faulty
P1	High pressure protection
P2	Low pressure protection
P3	Compressor current protection
P4	Temperature protection of compressor discharge
P5	High temperature protection of condenser
P6	IPM module protection
LP	Low ambient temperature protection

# Appendix 1: Mounting plate dimensions

## Pro Series High Wall units

### 2.6 kW and 3.5 kW

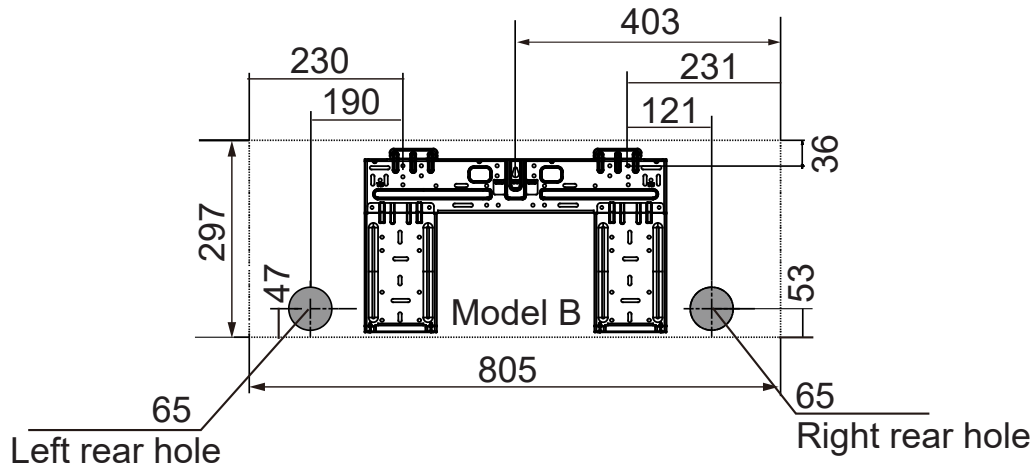

### 5.0 kW and 6.0 kW

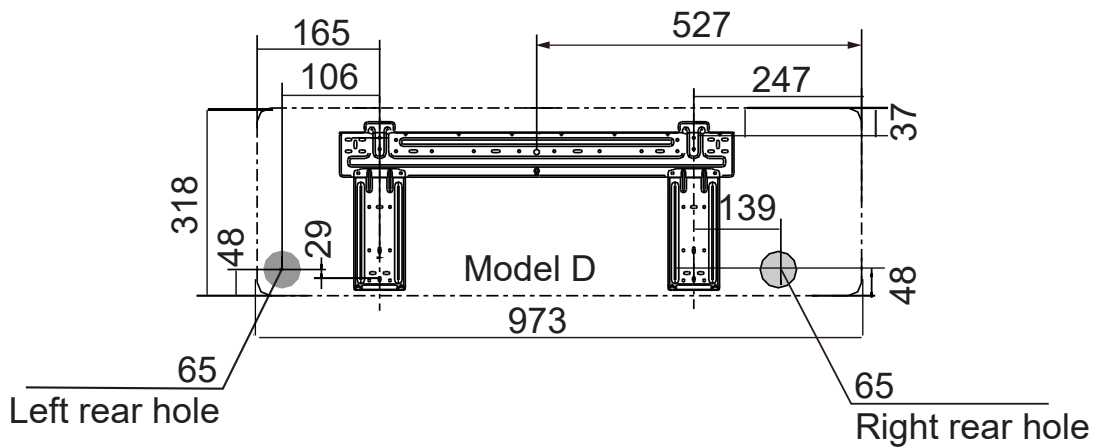

### 7.0 kW and 8.0 kW

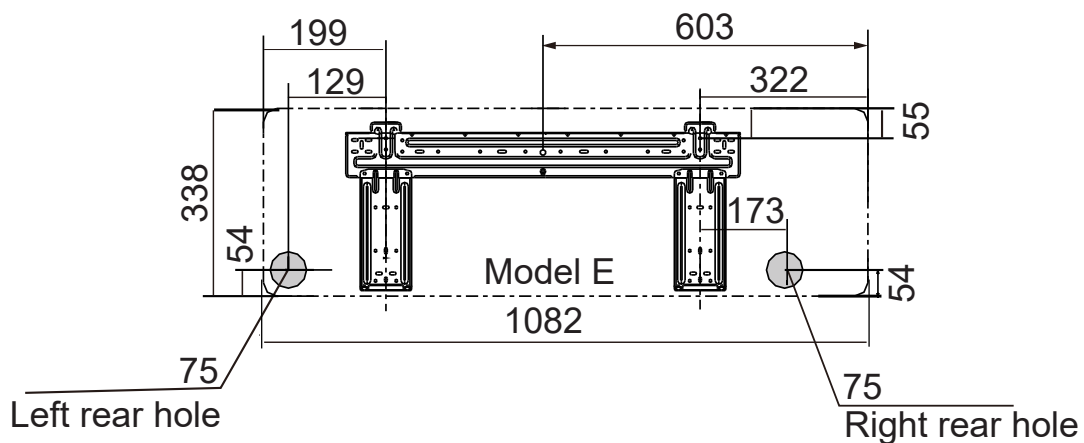



**Rinnai.co.nz**

Tel: 0800 746 624  
<http://www.youtube.com/rinnainz>  
<http://facebook.com/rinnainz>

Pro Series Multi Split System Installation Guide  
14098-C I 3-24