

INFINITY pipe cover Installation guide

Before installation check for damage, do not install any damaged items, and check all components have been supplied. Read these instructions to get an overview of the steps required before starting.

With Rinnai's current range of water heaters, assembly can be done by the homeowner—this is because assembly does not require taking the cover off the water heater.

The pipe cover is approximately the same width and depth of the water heater and conceals approximately 450 mm of pipework below the unit.

Pipe cover	Suitable for
R1385	Rinnai INF A16-A26 Rinnai INF VT16-VT26*
R1385G	Rinnai INF A26 Graphite™
R1402SC	Rinnai INF HD250*
R1408	Rinnai INF EF24*
R1408SC	Rinnai INF HD200 / HDi200*
R1416	Rinnai INF EF26
R1416G	Rinnai INF EF26 Graphite™

* Discontinued models

If the screw pack is lost a replacement pack can be ordered:
R5060 / R5060G* - Screw pack INFINITY pipe cover.

* R5060G is the graphite pack for the graphite pipe cover



Important

Before installing the pipe cover turn off the power, water, and gas to the water heater.

Assembly

1. Assemble the top frame to the right and left side panels with four M4 screws and washers. Note the orientation of the frame, fold faces up, this is the only way it will fit on the water heater.
2. Secure the bottom bracket to the left and right panels with two M4 screws and washers.
3. Secure the rear bracket to the left and right panels with two M4 screws and washers.

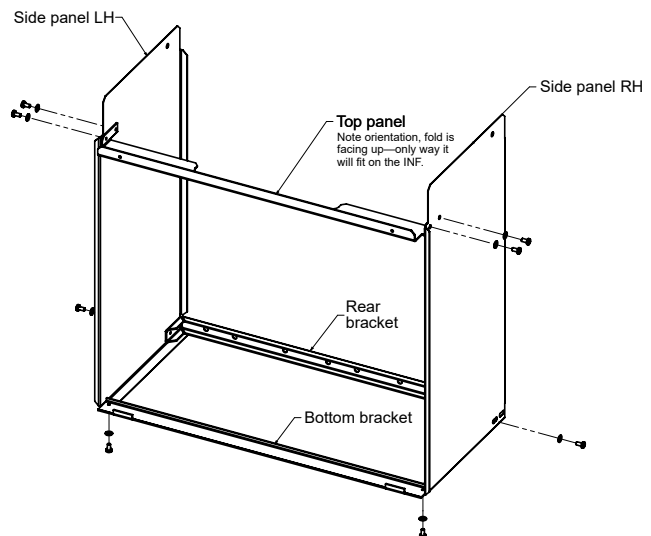

INFINITY pipe cover Installation guide

Pipe cover installation

1. Fit the pipe cover to the water heater using the two short stainless steel PK screws and nylon washers.
2. Use the #10 x 40 ZP PK screws to fasten the rear bracket to the wall. Use suitable anchors for the wall if required (not supplied).

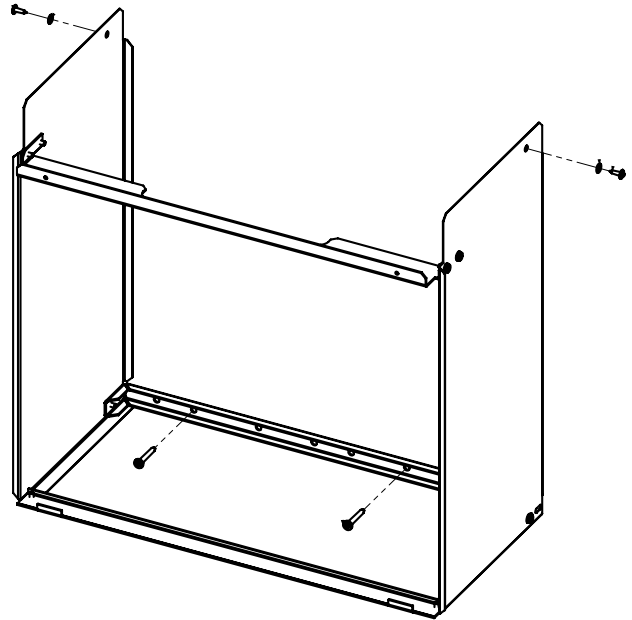

Fitting the front panel

1. Fit the two slots in the lower edge of the front panel onto the tabs of the bottom bracket. Where necessary readjust the pipe cover assembly to align with the water heater and that all components are still square.
2. Use the two M4 INFINITY pipe cover screws (M4 plastic capped thumbscrews) to fasten the front panel to the top frame.
3. Turn on the power, water, and gas to the water heater.

