

Models: RDV2320FN, RDV2320FL

Novo Cube

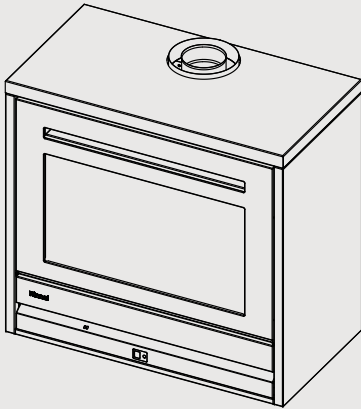

Novo Freestander - cabinet base

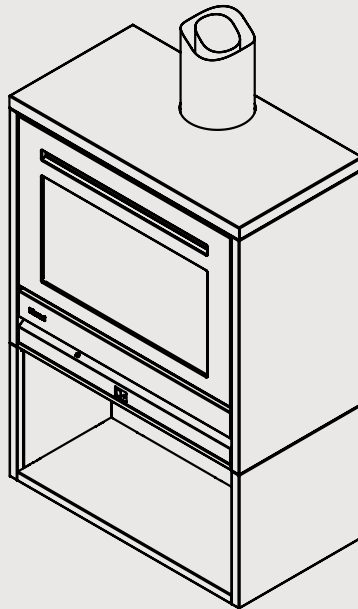

Novo Freestander - plinth base

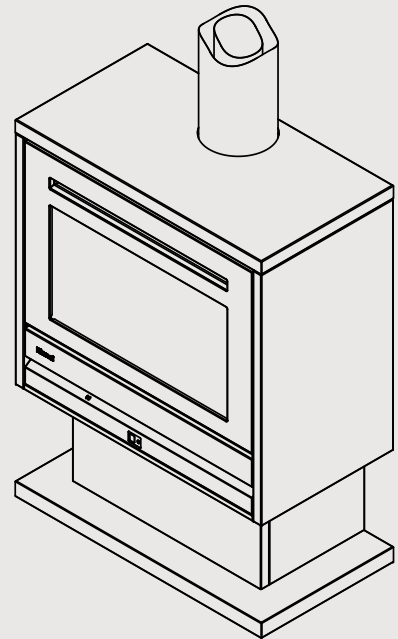

Novo direct vent Cube and Freestander gas fireplaces Installation guide

Rinnai

Important

Appliance must be installed with a Rinnai approved flue system.

This appliance shall be installed in accordance with:

- Manufacturer's installation instructions

Current:

- AS/NZS 5601 Gas Installations
- AS/NZS 5263 Gas Appliances General Requirements
- AS/NZS 3000 Electrical Standards
- AS/NZS 3500 Plumbing and Drainage Standards

For use with Natural Gas or Universal LPG as indicated on the appliance.

Appliance must be installed, commissioned and serviced by an authorised person, being in New Zealand a licensed gasfitter.

Warning

Improper installation, adjustment, alteration, service or maintenance can cause property damage, personal injury or loss of life.

For more information about buying, using, and servicing of Rinnai appliances call: 0800 RINNAI (0800 746 624).

Rinnai New Zealand Limited
105 Pavilion Drive, Mangere, Auckland
PO Box 53177, Auckland Airport, Auckland 2150

Phone: (09) 257 3800
Email: info@rinnai.co.nz
Web: rinnai.co.nz
[youtube.com/rinnainz](https://www.youtube.com/rinnainz)
[facebook.com/rinnainz](https://www.facebook.com/rinnainz)

Contents

Before you start	4
Specification	5
Dimensions	6
General clearances	7
Material selection.....	8
Gas supply and connection	10
Electrical supply.....	11
Novo cube installation	12
Aeration plates.....	14
Novo freestander and cabinet installation	15
Novo freestander and plinth installation	18
Burn media installation	22
Commissioning	24
Wi-Fi module installation (if applicable).....	25
Frame installation	25
Test operation and lighting sequence	26
Installation checklist and customer handover.....	26
Wiring diagram	27
Novo flueing.....	28
Novo freestanding flueing options	29
Novo freestanding flueing overview.....	30
Novo freestanding flue kits and components	31

Appendix

Material selection calculations.....	35
--------------------------------------	----



Installer please note

If the Wi-Fi module retrofit kit has been purchased as an accessory, it is ideal to have the homeowner present to test the Wi-Fi connectivity and correct operation of the fire.

Before you start

Unpack the appliance and components and check for damage. DO NOT install any damaged items. Check all components have been supplied, refer below, and that **you have the correct gas type**.

Read these instructions to get an overview of the steps required before starting the installation. Failure to follow these instructions could cause a malfunction of the appliance. This could result in serious injury and/or property damage.

Novo DV Cube

- ✓ Engine
- ✓ Cube wrap¹
- ✓ Outer frame¹
- ✓ IR remote
- ✓ Stainless steel gas pipe
- ✓ Brass adapter
- ✓ Aeration plates and screws²
- ✓ Log set and granules³
- ✓ Operation, and installation guides

¹ Engine, wrap, and frame come fully assembled ² Two are factory fitted on the fire, two are supplied in the accessory pack

³ Supplied inside the fire



Novo freestanding vertical flueing

Images are representative of some flueing options, components will be dependent on flue configuration and installation.

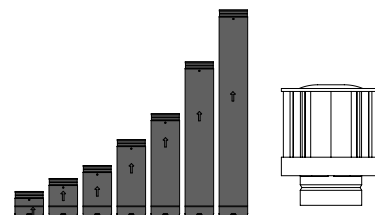

OPTIONAL ACCESSORIES

Novo Freestander - cabinet base (R2362GL)

The cabinet comes as a flat pack. An additional flexi and connector is also provided as a longer gas connection is needed.

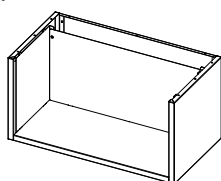

Novo Freestander - plinth base (R2363GL)

The plinth comes as a flat pack. An additional flexi and connector is also provided as a longer gas connection is needed.

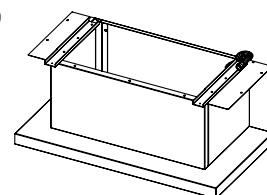

Novo freestanding mesh frame: R2371

Black integrated mesh guard, can be easily installed, no fixing required. Designed to protect against touching the hot surface of the glass¹.



Wi-Fi module retrofit kit: R7000

Kit enables the fire to be connected to the Rinnai Fire Wi-Fi App for full thermostatic control, as well as other features such as timers.



¹ The mesh will still get very hot—it is not a fire guard

Specification



A direct vent (room sealed) freestanding gas fireplace with glass front and convection fan, pushing warm air from the top of the appliance. Operated using a simple IR remote to control flame height and fan speed, or by the Rinnai Wi-Fi app (optional accessory) that allows full thermostatic control, as well as other features such as timers.

Input: 14-30 MJ/h
 Output: 3-6.6 kW*
 Efficiency: 77%
 Heating area: 65-112 m²**
 Gas type: NG or ULPG

* Will vary according to gas type and flue configuration

** Will vary depending on location in NZ

Suitability	Suitable for freestanding installations in open plan areas and living rooms. As a room sealed appliance it can also be installed in larger bedrooms if this meets the 6.10.6.1 requirements of AS/NZS 5601.1.
Data plate	Lower RHS of the base panel (in front of the gas control)
Convection fan	120 V AC 50 Hz 2-speed centrifugal blower
Gas connection	Brass ½ " BSPT male fitting. The gas supply terminates inside the unit—lower RHS of the appliance.
Ignition	230-240 V AC 50 Hz high voltage electronic spark generation
Installation considerations	Room size, smaller rooms will heat up quickly, and due to the heat of the appliance, the fire will turn to a low setting once the set temperature has been reached.
Flue	Direct vent coaxial* flue. Draws air for combustion from the outside and expels combusted gases to the outside. Appliance must be installed with a Rinnai flue system. <ul style="list-style-type: none"> • inner Ø 100 mm • outer Ø 170 mm
Noise level	37-45 dB(A)
Electrical	A 1.5 m power cord with a three pin plug is supplied. The power cord passes through a slot in the back left hand corner of the appliance. High - 50 W Standby - <3 W
Safety devices	Flame failure sensing system, pressure relief, overheat safety switch, air temperature sensor, thermal fuse, overcurrent fuse, and spark detection.
Temperature control	Operated by using the basic IR remote to control flame height and fan speed, or for more features, such as timers and thermostatic control, using Rinnai's Wi-Fi fireplace controller app—Wi-Fi module purchased as an optional accessory.
Weight	Novo Cube = 75 kg Novo Freestander cabinet base = 14 kg Novo Freestander plinth base = 10 kg

* Coaxial: One flue, the exhaust flue is nested inside the air intake flue—these are rigid flues



Coaxial

Dimensions

Novo Cube

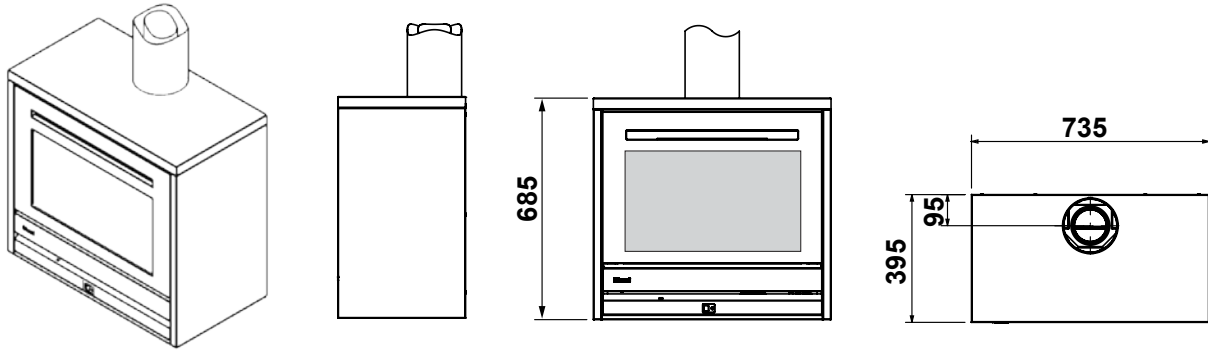

Novo Freestander - cabinet base

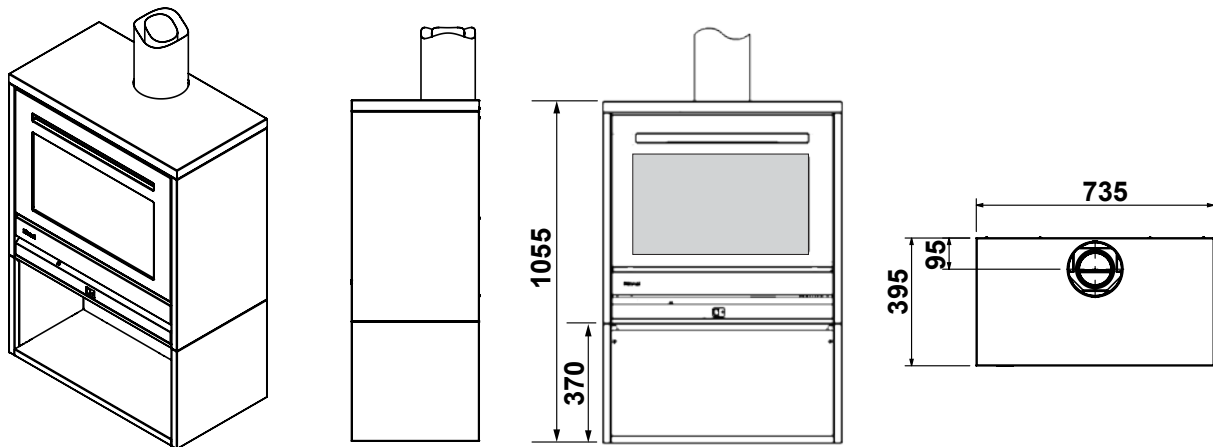

Novo freestander - plinth base

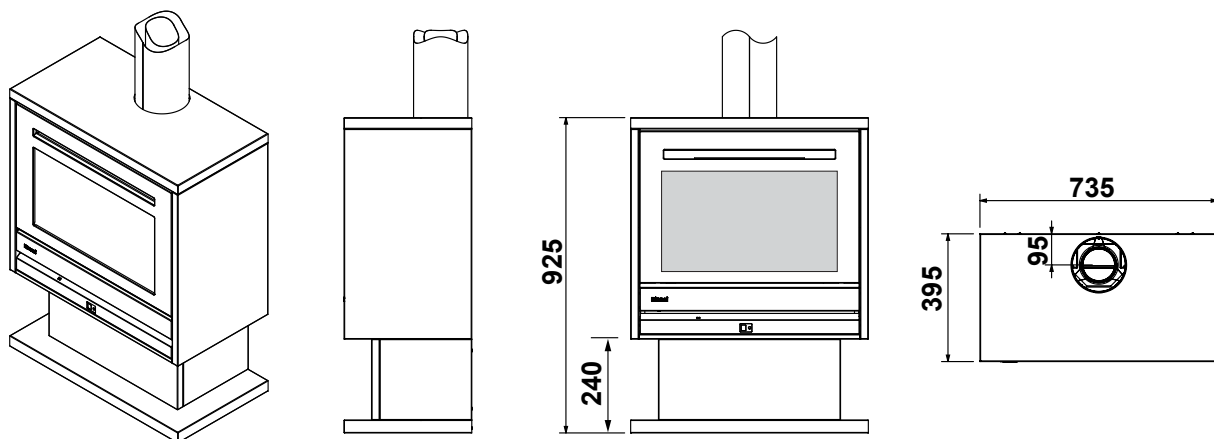

Viewable glass dimensions

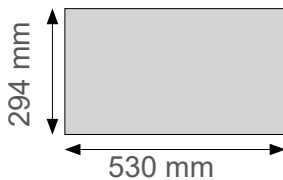

General clearances

The Novo freestanding models have an additional metal wrap which significantly reduces heat transfer. This means the unit can be installed into tight spaces, can be built-in, and can be positioned close to walls if the building materials are suitable. For further information on material selection refer next page.

General clearances from combustibles

The clearances in this diagram are minimum clearances. The Novo must not be installed where curtains, furniture, or other combustible materials could come into contact with the fire while it is operating. The 1000 mm clearance is in front of the fire.

The general clearances shown below on the Novo Freestander (with cabinet base) apply to all the Novo freestanding models.

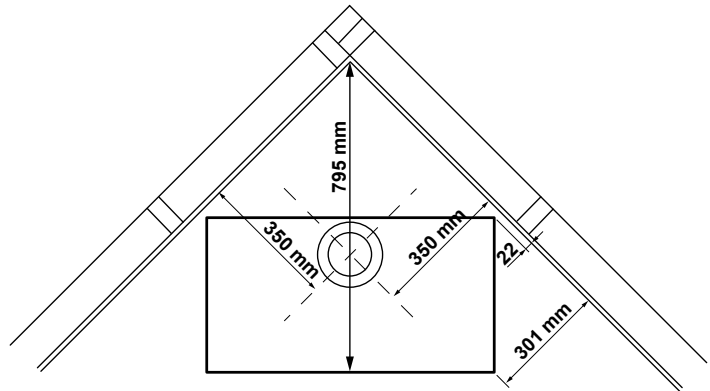
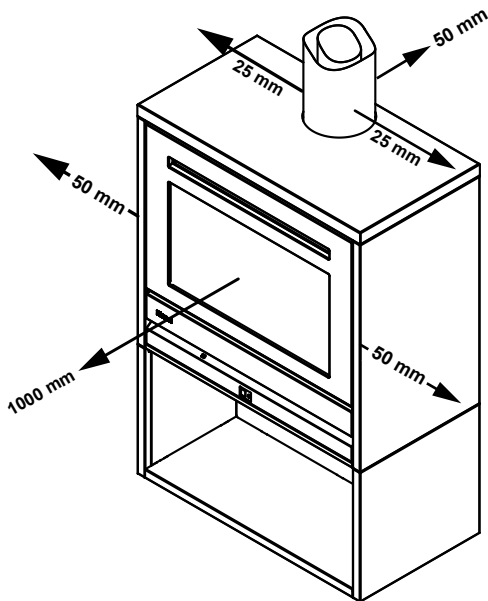

Floor protection

Heat radiating from this fire may over time affect the appearance of some materials used for flooring, such as carpet, vinyl, cork, or timber. We don't recommend installing the Novo Cube directly on the floor if sensitive or unrated materials are used (refer next page) unless there is some protection placed in front of the appliance, such as a mat.

Material selection

The temperature in front of the fire (approximately 200-350 mm x 400 mm wide) can reach up to 40 °C above ambient, which is why material selection is important. For example, vinyl planks are a popular option for flooring, however vinyl is only rated for ambient temperatures. In this example it would not be recommended that the fire is installed directly on the floor unless there was some form of floor protection in front of the fire.

Some material selection guidelines, depending on the material rating, are shown below.

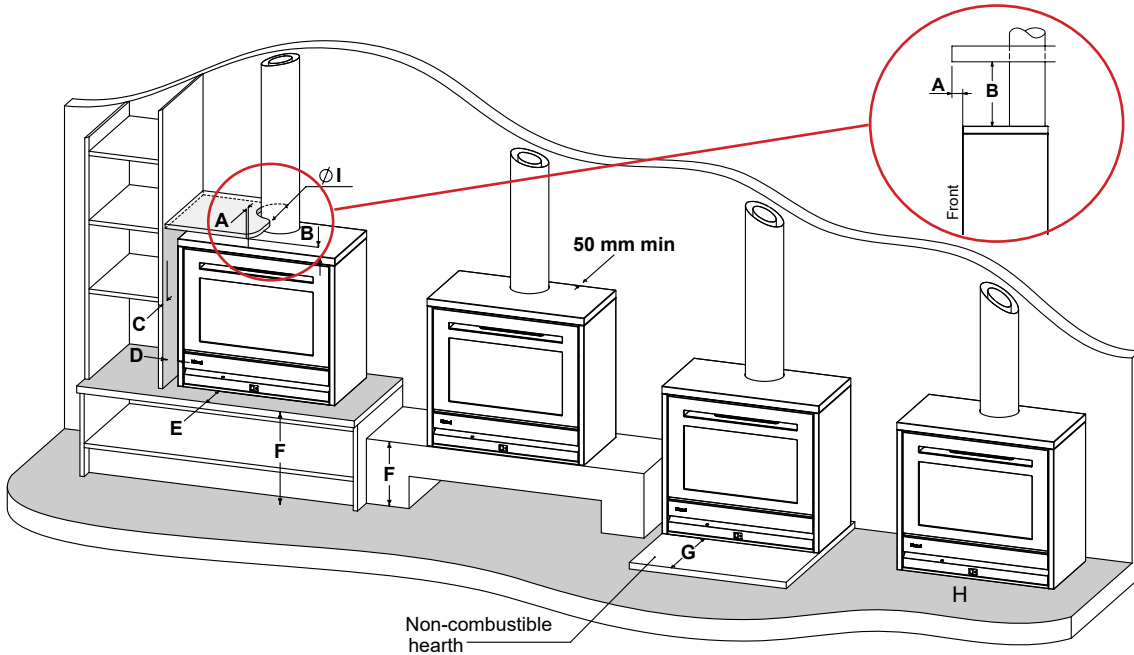

Dim.	Description	Material temperature rated above ambient		
		Non-combustible materials or materials rated 60 °C or higher	Materials rated to a maximum of 50 °C	Unrated materials, anything up to a maximum of 20 °C
A	Overhang	No restriction as long as materials within 400 mm to the side (D) are of the same rating	<ul style="list-style-type: none"> Not suitable if B is under 250 mm No restrictions if B is greater than 1000 mm If B is 300-1000, refer p.34 	
B	Clearance above	50 mm min.	100 mm min.	200 mm min
C	Side overhang	No restrictions	No restrictions if D is greater than 400 mm	
D	Side clearance	50 mm min.	50 mm min.	100 mm min.
E	In front	No restrictions	150 mm max.	100 mm max.
F	Clearance to floor	No restrictions	150 mm min.	240 mm min.
G	Hearth depth	No restrictions	400 mm min. of non-combustible material	450 mm min. of non-combustible material
H	Directly on floor	No restrictions	Not suitable for heat sensitive materials	
I	Flue clearance	25 mm min.	50 mm min.	

The shaded cells denote measurements A, B, C, and D. These figures are dependent on each other and the type of installation. There is some wiggle room to these dimensions if they follow some specific calculations. These calculations are based on figures obtained during in-house temperature testing. For more information refer to the next page, and page 34.

Just because a material is rated to higher than 60 °C does not mean it will not deteriorate when exposed to heat cycles. Always refer to the material supplier for suitability. The temperatures given are assuming the fire is operating in a room temperature of no more than 25 °C. Operation in higher ambient temperatures may result in higher surface temperatures. Non-combustible materials should be made of heat resistant material.

Installation examples

Cube installed on a combustible platform

Depending on material, refer table on previous page. The platform could extend 150 mm or 100 mm maximum in front of the fire. This is dimension E in the table.

The height of the platform would need to be at least 150 mm or 240 mm high. This is dimension F in the table.



Cube installed on a non-combustible floating hearth

Only requirement for non-combustible material is a 50 mm clearance from the back of the fire to the wall.

If the material is rated 50 °C or below (above ambient) then:

- 50 mm clearance from the back of the fire to the wall, and a 50 mm clearance to the sides and top.
- In front, hearth could extend 100 mm or 150 mm maximum, this is dimension E in the table.



Freestander with plinth base installed on a wooden floor

Using the table on the previous page there would be no restrictions except a 50 mm clearance from the back of the fire to the wall. The plinth automatically gives the 240 mm minimum clearance from the bottom of the fire to the wooden flooring—this is dimension F in the table.



Cube installed in an alcove

If all materials are non-combustible then the only restrictions are:

- 50 mm clearance from the back of the fire to the wall
- 50 mm minimum clearance above and to the sides, and that the material above the fire is the same as the material to the side of the fire.
- The flue requires a 25 mm clearance.

If the material is rated 50 °C or below then the parameters in the table on the previous page, and the material selection calculations apply, refer p. 34. There is also an additional explanatory diagram on p.35.



Gas supply and connection

Gas pipe sizing must consider the gas input to this appliance as well as all other gas appliances in the premises. The gas meter and regulator must be specified for the total gas rate. An approved sizing chart such as the one in AS/NZS 5601.1 should be used.



The use of a rubber hose for any gas connection to a fixed appliance is NOT authorised by the manufacturer.

The gas supply position will vary slightly based on if a Novo Cube has been ordered or Freestander with a cabinet / plinth, refer installation pages for more information.

Gas connection

Firmly grasp the stainless steel flexi pipe and bend to line up with the gas control valve inlet, then attach the pipe to the gas control valve and tighten.

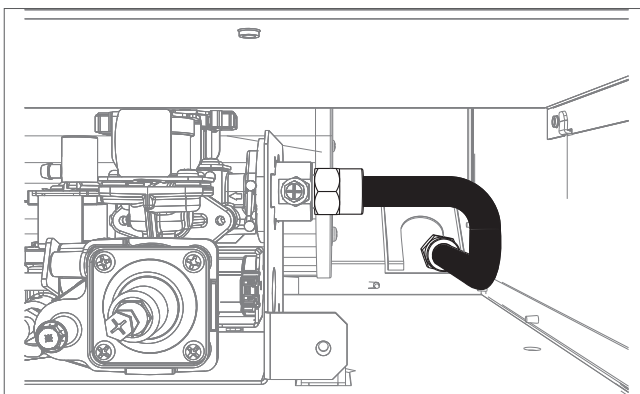

Please note: The gas and power supply can be brought in through the base of the fire.

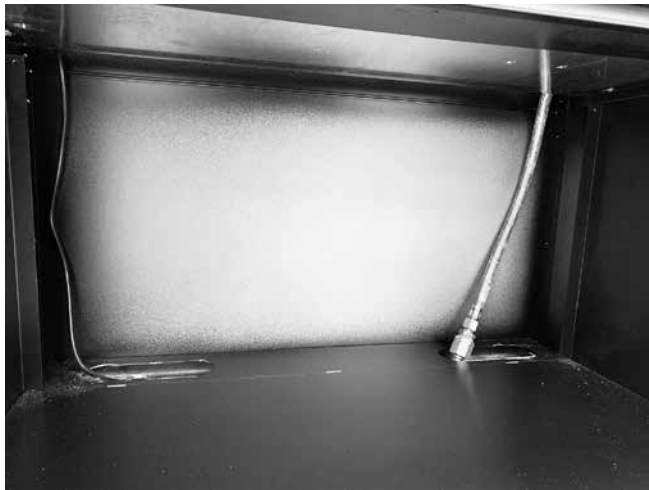

Electrical supply

The Novo free standing fire is supplied with a power cord (length 1500 mm) and a 3-pin plug. The standard electrical connection passes through the rear panel. The power cord can be drawn back inside the outer panel and brought into the fire from below if preferred. This is more likely with the cabinet or plinth installations, especially if they are not installed close to the wall. If shifting the position of the power cord, it is recommended that the rubber grommet is left in place to cover the hole in the back panel.

The connection is either direct wired* or connected to a dedicated 240 V, 10 A earthed power point. The electric isolation switch must be accessible after the appliance has been installed.

The heater must not be located immediately below a socket outlet (potential fire hazard).

The power cord is not fire rated and should not come into contact with the unit. If the power cord is damaged, it must be replaced by a licensed tradesperson. This must be a genuine replacement part available from Rinnai.

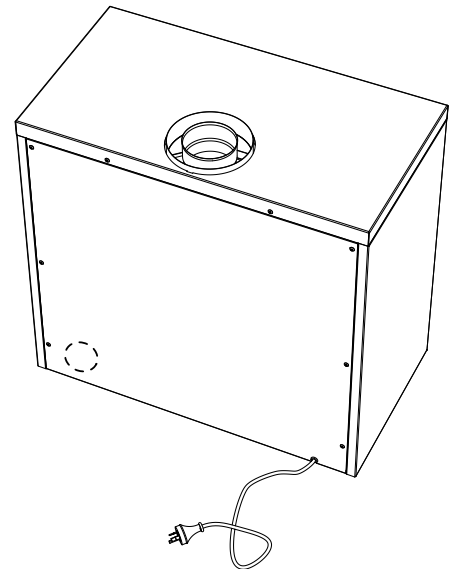

* Consult a qualified electrician if direct wiring is required as it must comply with AS/NZS 5601 and AS/NZS 3000 and other relevant local regulations

Novo Cube installation

Unpack the fire

1. Remove the frame (two screws).
2. Remove the control panel (two screws) and unplug the ON/OFF switch.
3. Remove the mounting plate (two screws) and lift the fire off the plate.

Fix the mounting plate to the floor

1. Mark the position of the flue centreline on the floor. Note the minimum distance from the wall (50 mm). This is required to allow the back panel of the fire to be fitted to the mounting plate.
2. The gas and power supply can be brought in through the base of the fire. The pipe/ power cord must enter within the shaded area shown on the next page. The hole can be bigger, but must not extend beyond the fire footprint. If the power is to be brought in from

the back, there is a knockout in the bottom right corner (viewed from the back of the fire) of the back panel that can be removed with pliers. There is also a knockout for the gas on the back panel.

3. Fix the mounting plate to the floor using a minimum of four screws (not supplied). For seismic restraint each fixing must be capable of withstanding a pull force of 1.5 kN. A 10 ga screw 35 mm into solid timber (this may mean solid blocking is required under the floor), or a 8 mm dynabolt type masonry fastener.

Check the flue configuration

Check the flue configuration, do the aeration plates need adjusting or additional plates added? Refer to page 14 for more information.

Install the fire back onto the mounting plate

Follow the reverse steps for unpacking the fire.

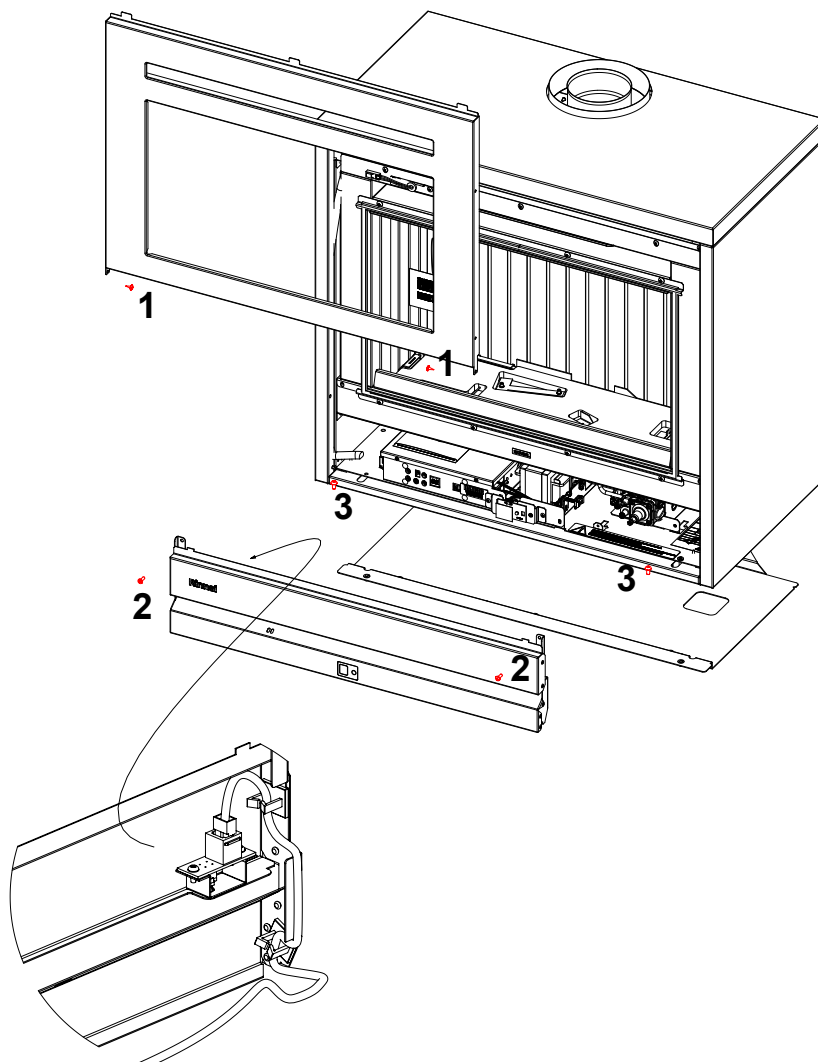

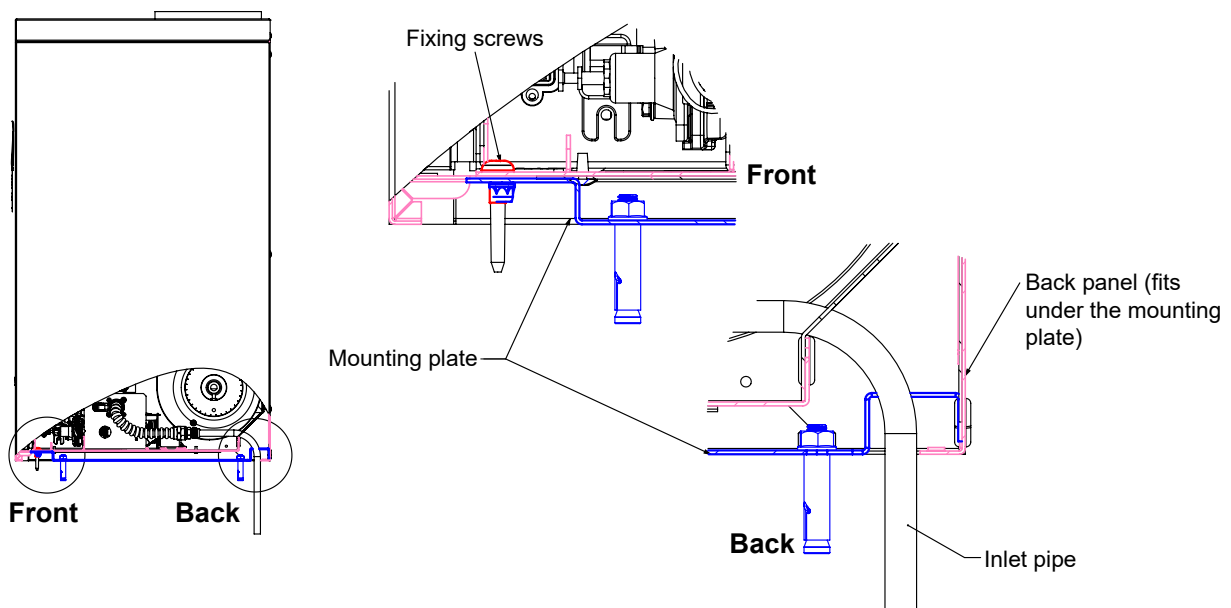
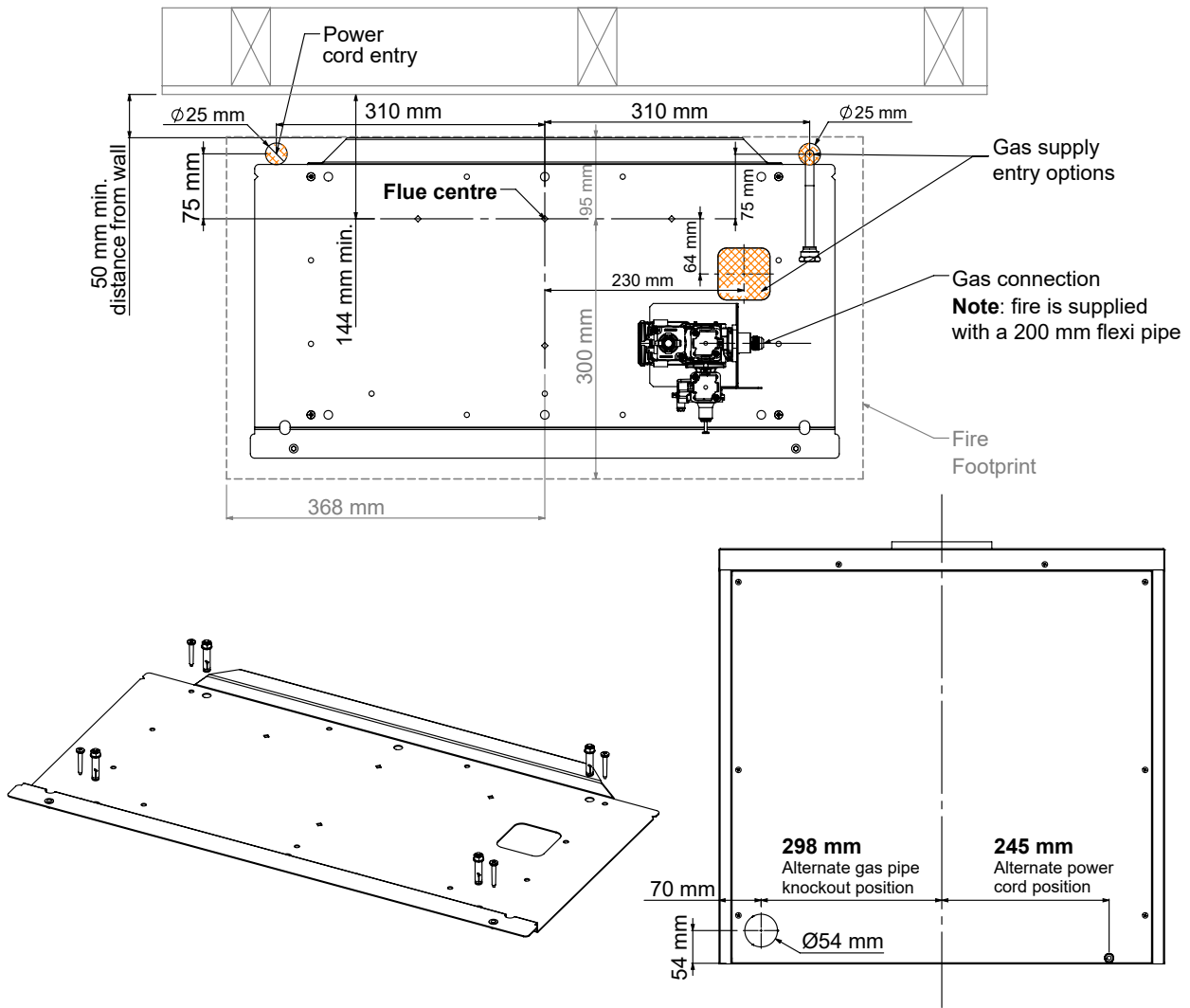

Aeration plates

The Novo has an aeration plate factory fitted either side of the unit, refer photo. The plates are fitted in a position for flue lengths between 3-5.5 m. Two additional plates are supplied in the accessory pack, these are for flues between 5.6-8 m.



To control flame lift and efficiency on long flues (anything over 3 m) it's important the aeration plates are configured correctly—refer chart below.

Aeration plate configuration

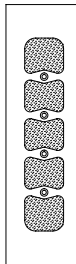
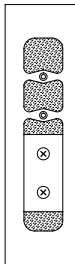
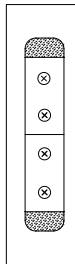
Vertical flue height	< 3 m	3-5.5 m	5.6-8 m
Action required	Remove factory fitted aeration plates 	No action required 	Fit additional plates supplied in accessory pack 

To maintain balance within the combustion chamber, it is important to fit the plates equally to both sides. The chart shows the plates required for any given flue length. Fitting more plates than shown may have a detrimental effect on startup performance, especially in very cold areas.

Changing the aeration plate settings

Avoid sliding the flue adapter assembly around too much when fitting. This may cause the gaskets to be incorrectly sealed.

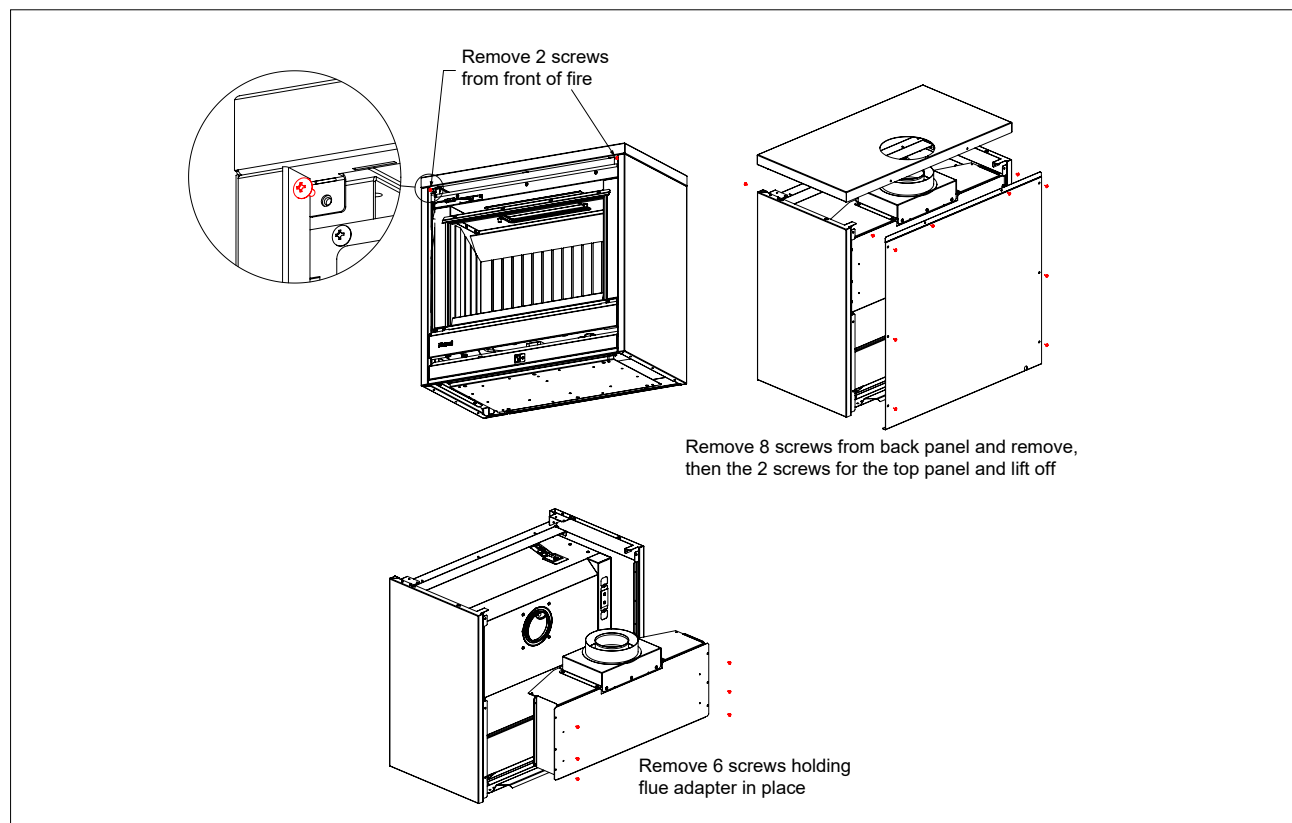

Novo Freestander and cabinet installation

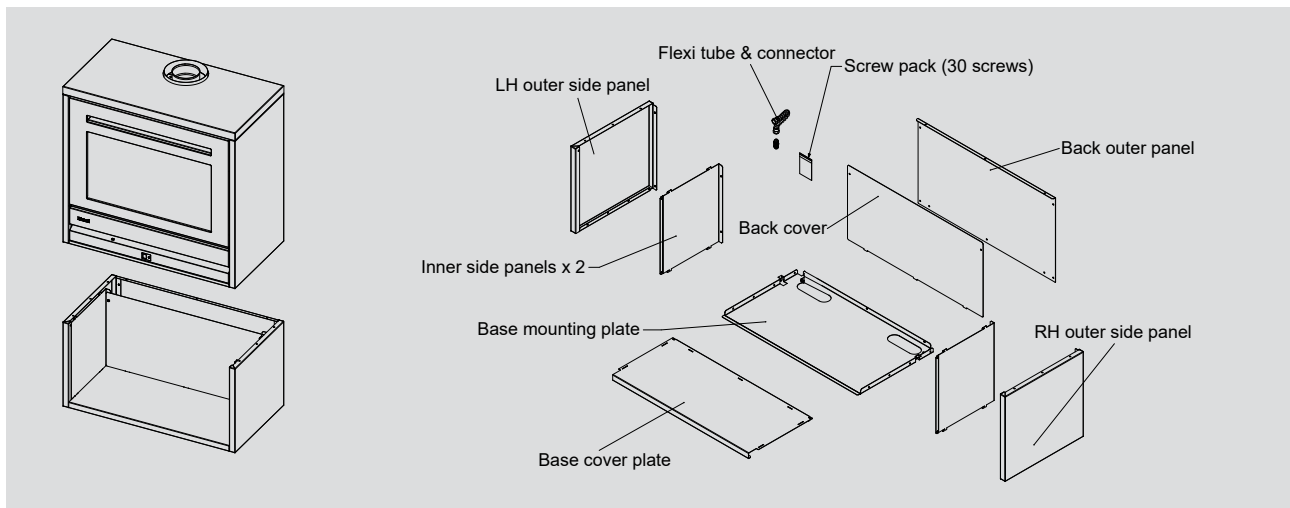

There are two ways to install the cabinet to the Novo freestanding cube:

Complete assembly

1. Prepare mounting area for fixing and services
2. Lay the fire on its back
3. Fix the partially assembled cube to the fire
4. Fix the fire in place and connect power and gas supplies

Build up (requires two people)

1. Prepare mounting area for fixing, power and gas supplies
2. Fix partially assembled cube base to the floor
3. Lift fire onto the cube and fix together
4. Connect power and gas supplies

Mounting area and mounting plate

For this installation you DO NOT use the fire mounting plate, use the base mounting plate provided with the cabinet kit.

1. Mark the flue centre on the floor.
2. Fold the base panel locator tabs up as shown on the next page.
3. Fix the base mounting plate to the floor using a minimum of four screws (not supplied). For seismic restraint each fixing must be capable of withstanding a pull force of 1.5 kN. A 10 ga screw 35 mm into solid timber (underfloor solid blocking may be required) or an 8 mm Dynabolt type masonry fastener would suffice.

Do not fix the fire in place yet unless there is sufficient room behind the fire to get a screwdriver in to fix the back panel in place, and you are prepared to lift the fire onto the cabinet.

Make the cabinet

Working on a flat surface, assemble the outer cabinet panels as shown on the next page. Make sure the cabinet is square and that the top surfaces are flush with each other.

Fix the cabinet to the fire and check aeration

Unpack the fire, refer p.12. To make the fire lighter and easier to manage, remove the glass front, log set, and ceramic panels from the inside of the combustion chamber.

Before doing anything else, check the aeration plate setting, refer previous page.

Fix the cabinet (make sure panels are flush, especially on the front and sides) to the fire, either:

- Lay the fire on its back and fit the cabinet using nine screws, stand it up and fix in place, or
- Fix the cabinet to the floor, fit the cube onto the cabinet, and fix in place.

Connect services and commission

Connect the power and gas—there is a second stainless steel flexi tube connector supplied with the cabinet kit to make connection easier. Commission as per the commissioning instructions.

Fit cabinet panel covers

Refer next page.

Novo Freestander and cabinet installation cont.

Fit the base cover panel

Ensure the lower front edge of the panel is hooked under the front edge of the base mounting panel as shown below. The front faces **MUST BE** flush.

Fix the panels in place using two screws.

Fit side panel covers

Fit tabs into slots. Slide panels forward so the leading edge is behind the side panel. Fix in place, one screw per side.

Fit back panel

Fit tabs into slots. Fix in place—two screws.

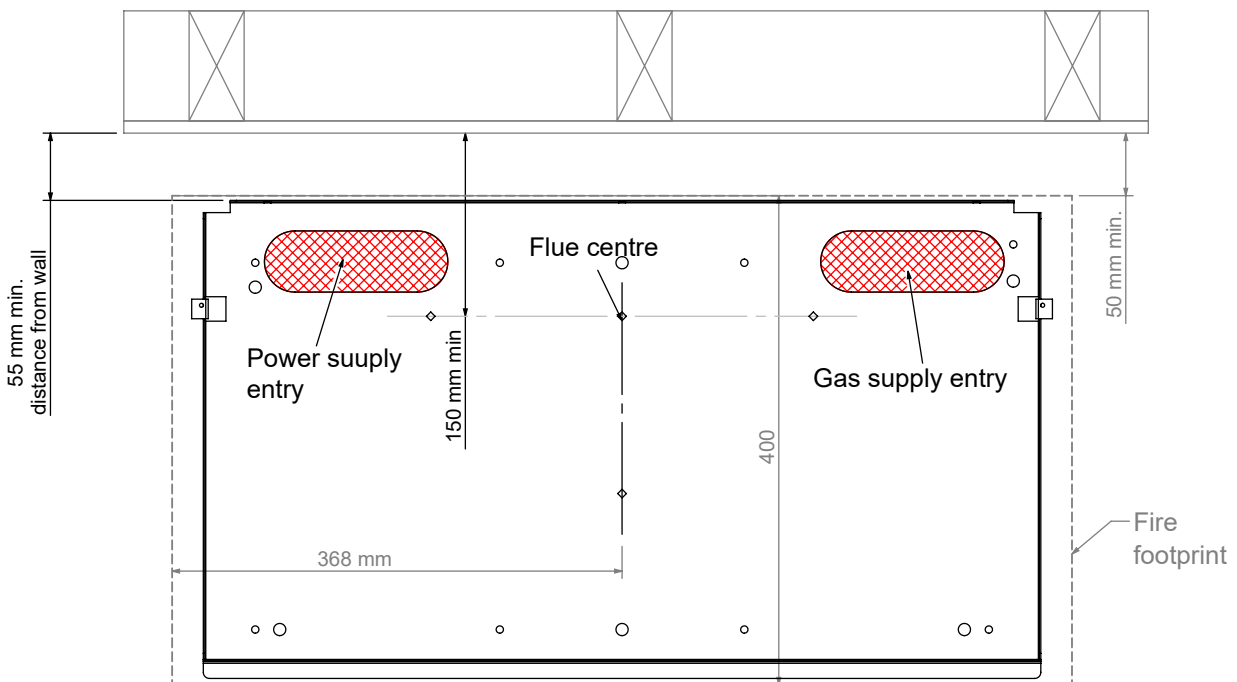
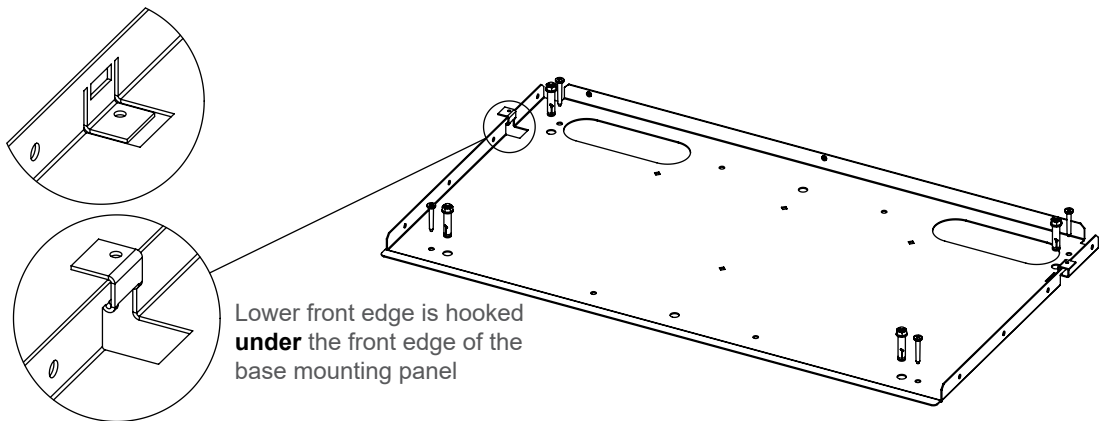

Cabinet assembly

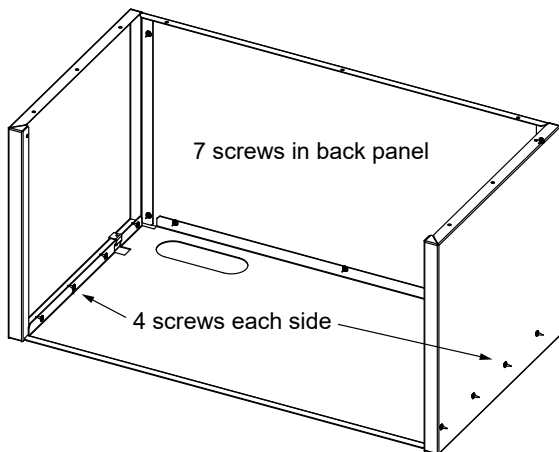

Fixing the fire to the cabinet

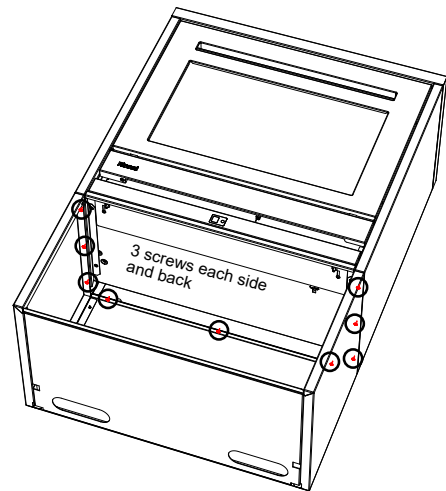

Power and gas supply

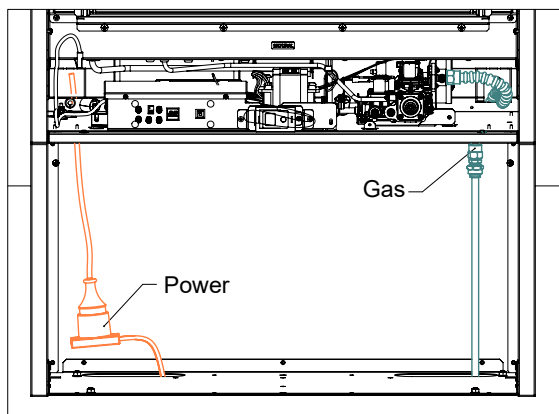

Fitting base cover panel

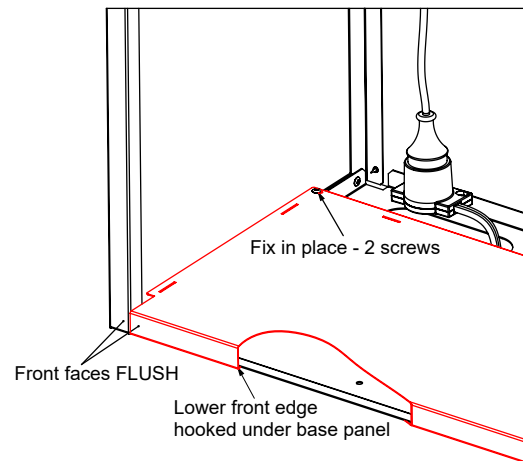

Fit side panel covers

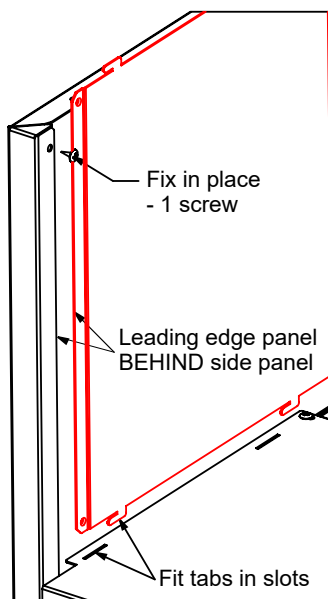

Fit back panel

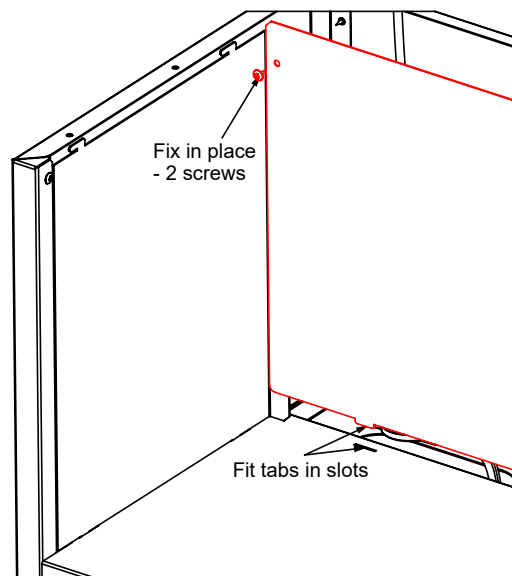

Novo Freestander and plinth installation

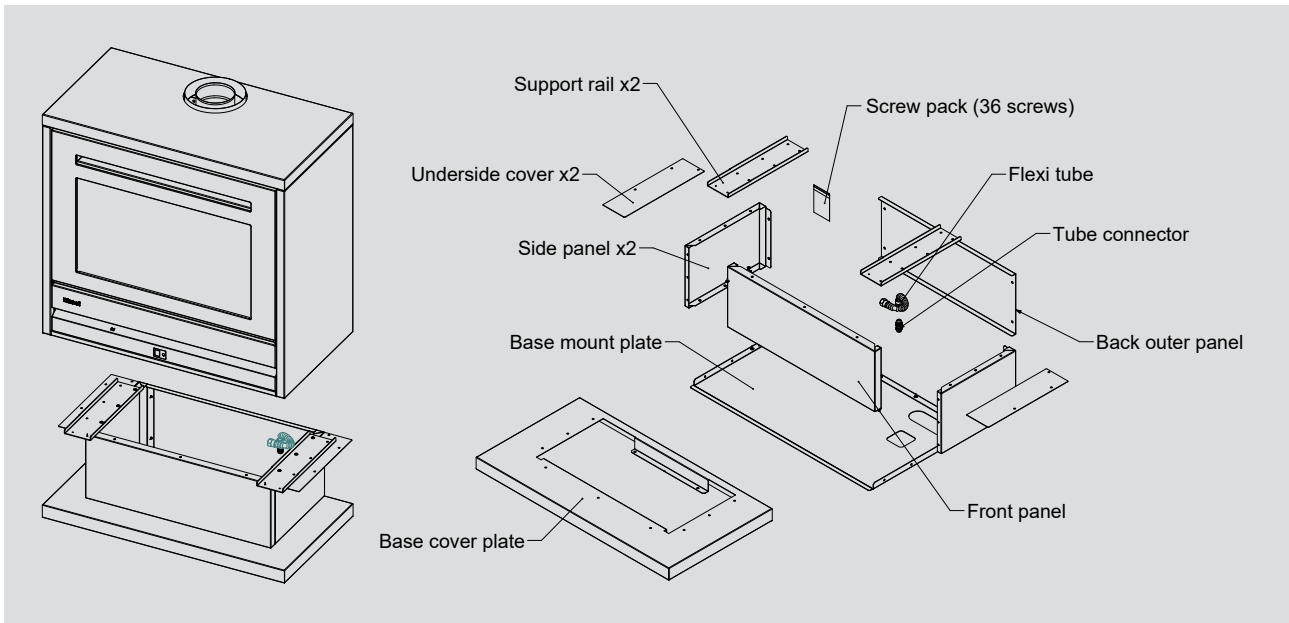

1. Mounting area and mounting plate

- Mark the flue centre on the floor.
- Place the base mount panel on the floor and line up with the centre marks, and mark the area for power and gas to enter. The alternate power and gas options shown in the cube installation also apply here.
- Check there is sufficient timber under the screw mounting holes to provide the required seismic restraint. If necessary, underfloor blocking may be required. A minimum of four screws, two front and back, are required. Each fixing must be capable of withstanding a pull force of at least 1.5 kN . A 10 ga screw 35 mm into solid timber or an 8 mm dynabolt masonry type fastener would be suffice.

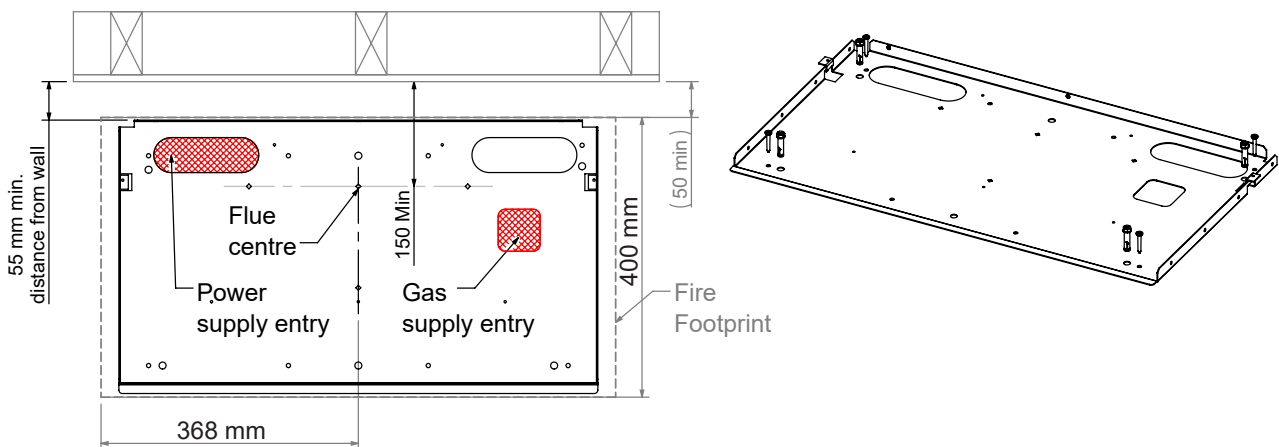

2. Prepare services

For best results the gas and power can be supplied through the plinth and into the base of the fire. The power will need to be hard wired.

Bring enough cable through the floor to reach at least 100 mm above the top of the plinth. Bring the gas supply through to within approximately 50 mm of the top of the plinth, flare the pipe, and fit the supplied flexi tube. This should be leak tested now as access through the back panel is limited once the fire is installed. The alternative is to drill a hole in the back of the fire for the gas supply and to remove the notch for the power cord.

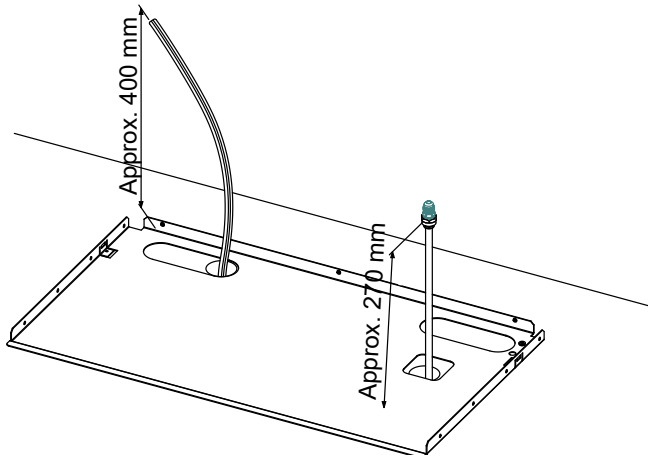

3. Assemble outer plinth panels

Working on a flat surface assemble the outer plinth panels as shown. Take care to ensure the plinth is square and that the top surfaces are flush with each other.

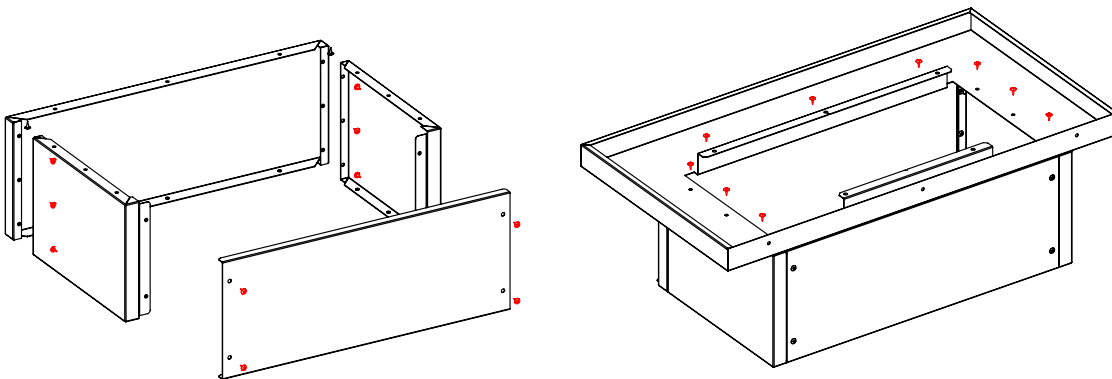

3. Fit panels to the base mounting plate

Fit the plinth to the base mounting plate by lifting the back edge of the plinth and sliding the front edge under the front lip of the base plate, then setting the edge back down. Hold in place with three screws.

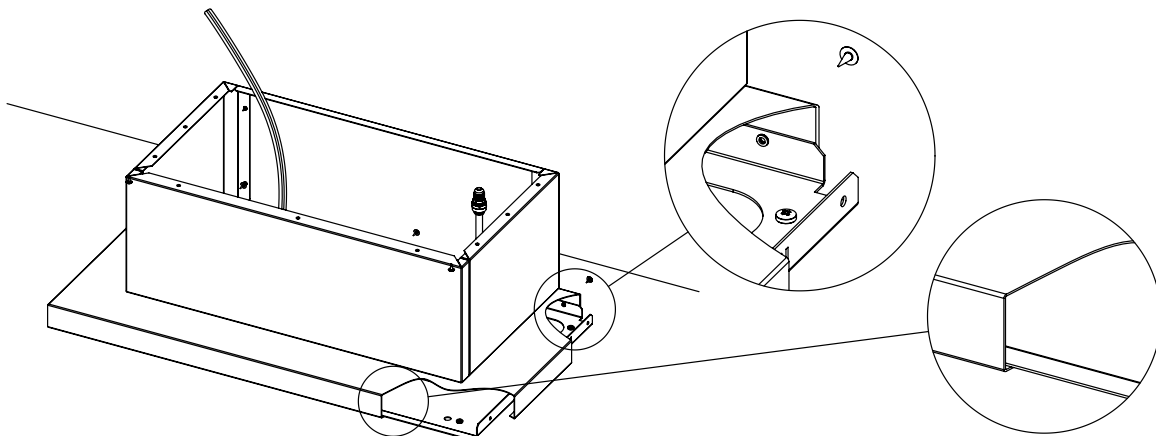

Freestanding cube + plinth installation cont.

4. Fix fire base plate to plinth

Unpack the fire, refer p.12 for more information. Remove the fire base plate and fix to the top of the plinth assembly using the stiffening rails as shown. Fit the second flexi pipe supplied with the fire.

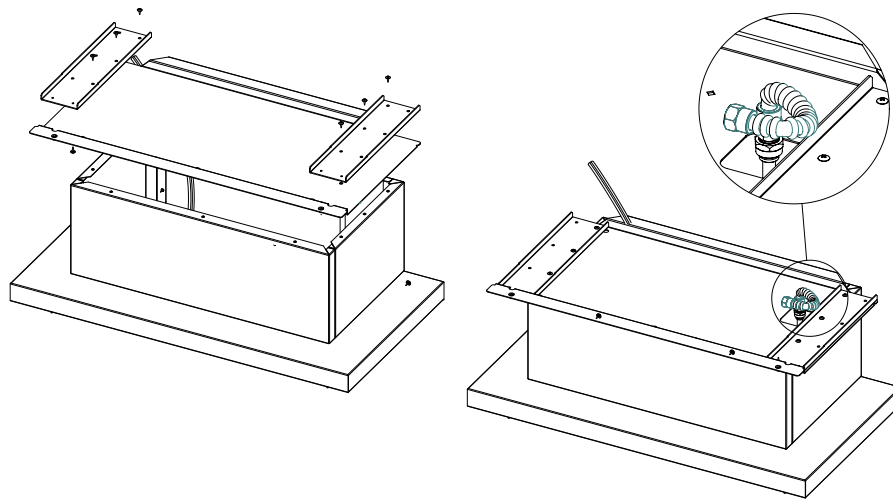

5. Check aeration setting

Check that the correct aeration shutter plates are fitted, refer p.14. It is still possible to change the aeration setting once the fire is installed, however it is much easier to do this beforehand.

6. Fit the fire to the plinth

Lift the fire onto the plinth and feed the gas supply tube through the hole in the back corner. The fire needs to be set approximately 20 mm back from the plinth, then slip forward so the bottom edge of the fire back panel sits under the back edge of the fire mounting plate.

Fix in place with 2 x M5 screws through the front edge of the fire, circled below.

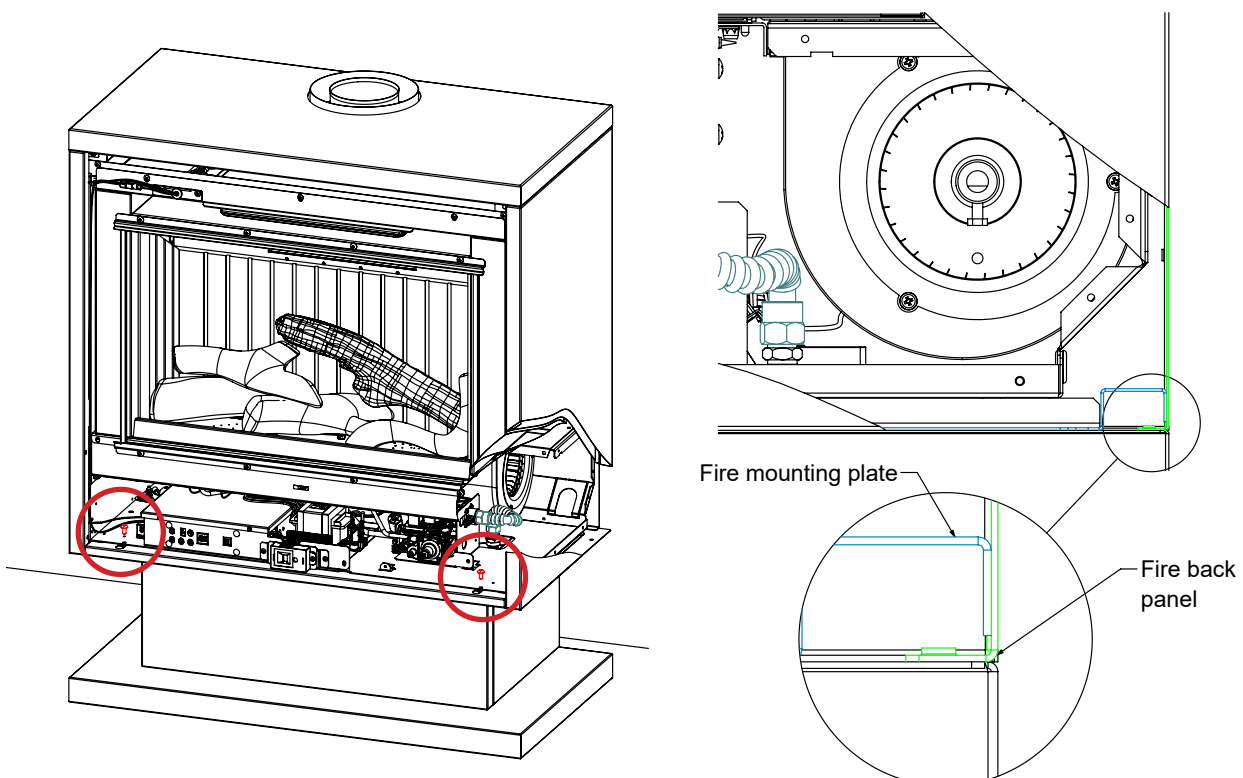

7. Connect services and commission

Connect the power and gas. Fit the underside covers, and commission as per the commissioning instructions.

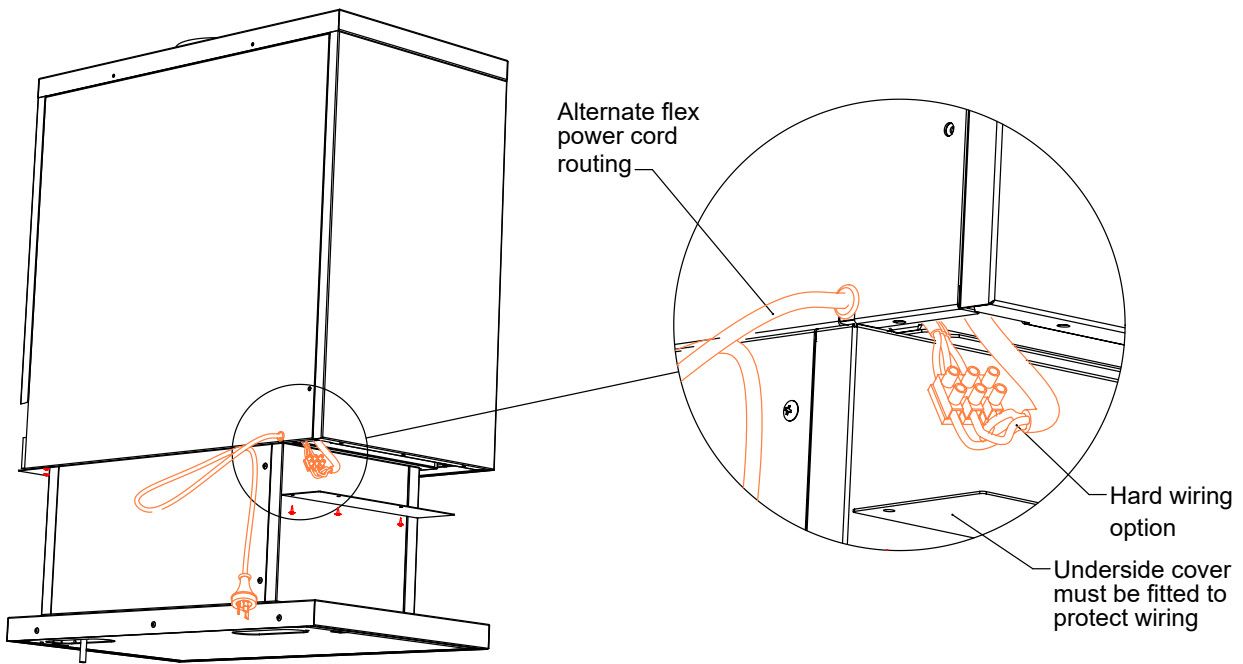

Burn media installation

The granule pack and log set, consisting of five logs, comes packaged inside the appliance. Use extreme care when handling the logs, they are fragile and will damage easily. The unit must never be used with broken logs or other burn media.

Experience has shown that the majority of performance problems are caused by burn media being installed incorrectly. Incorrect placement can create carbon build-up and affect performance. Please take the time to read and follow these instructions as malfunctioning due to incorrect placement is not covered by warranty.

The granules as well as being added to create a more realistic log effect (they diffuse the gas flames) also assist in soot prevention and are CRITICAL to the correct operation of the fire. Never pour the granules directly from the pack as dust particles and the granules may block the burner ports.



A four minute burn media installation YouTube video is also available on the Rinnai YouTube channel: <https://www.youtube.com/watch?v=I4ldLOHlacw&t=2s>

Place 31 granules around the burner ports (not directly over) as shown below. You will have granules left over.

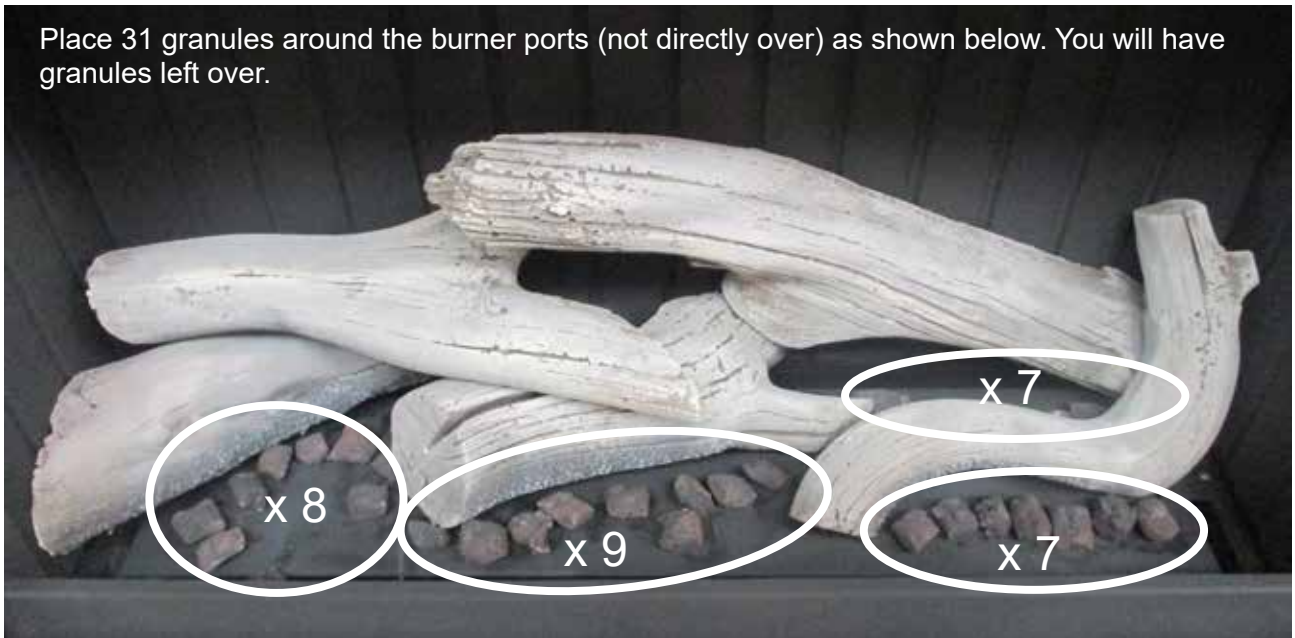

Ensure the left hand log is sitting on top of the two support brackets and NOT directly on the burner.





Commissioning

The gas pressures must be checked against those printed on the data plate of the appliance. The pressures are factory set and may not require adjustment. When checking the operating pressures the combustion chamber glass must be on.



A three minute commissioning YouTube video is also available on:
<https://www.youtube.com/watch?v=awaQkgAx6uk>

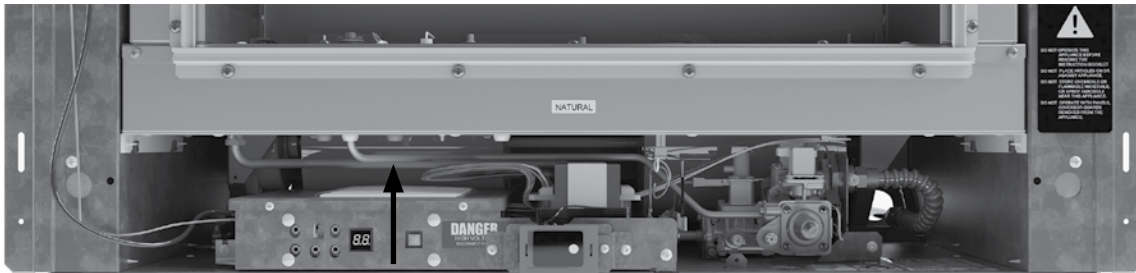

The commissioning sheet is located in a plastic pouch inside the unit on top of the PCB cover.

Follow the commissioning instructions to complete the gas pressure checks. When commissioning is complete check for full and correct operation of the appliance, and return the commissioning sheet to its plastic pouch.

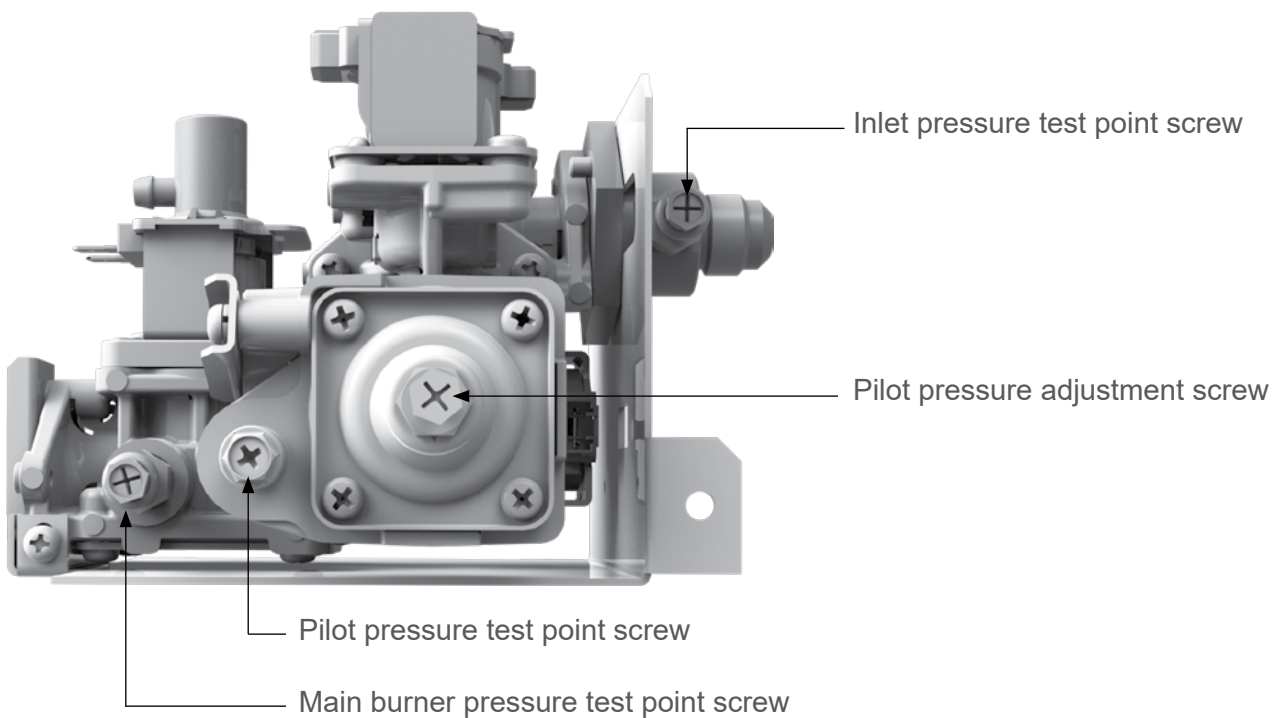

As per AS/NZS 5601.1:

E7 TESTING A CONNECTION MADE AFTER A TEST PROCEDURE

Any connection made after a test has been completed shall be checked for leakage at *operating pressure*. A suitable leak detection solution or other suitable leakage detection method shall be used and the connection left *gastight*.

Wi-Fi module installation (if applicable)

If the Wi-Fi module retrofit kit has been purchased as an accessory, complete the installation using the instructions provided in the kit. Once installation has been completed check, when the power is on, that the Wi-Fi LED flashes and turns a solid red. This indicates everything is ready for setup via a smart device. Go through the app sequence with the homeowner.

If unable to connect, the Wi-Fi board must be reset. The reset button is a small hole in the base of the board, underneath the LED. Using a paper clip or similar, press and hold the reset button for 10 seconds.



1. Wi-Fi LED
2. Wi-Fi module reset hole position

Frame installation



Before installing the frame make sure the ON/OFF button on the PCB control panel is in the OFF position, otherwise the button on the frame will not work.

1. Ensure the CAT5 cable is installed into the ON/OFF button on the frame and clipped in place in the front of the fire.
2. Fit the frame over the top flange of the fire.
3. Fix the frame to the fire using the two supplied black M4 screws (circled). It is CRITICAL to the safe operation of the fire that these screws are in place as this seals the fire.
4. Fit the inner frame to the fire by setting it into the allocated slot of the outer frame and sliding it down.
5. On the PCB control panel, return the button to the ON position. Check the operation of the ON/OFF button on the frame and that the remote control is working.

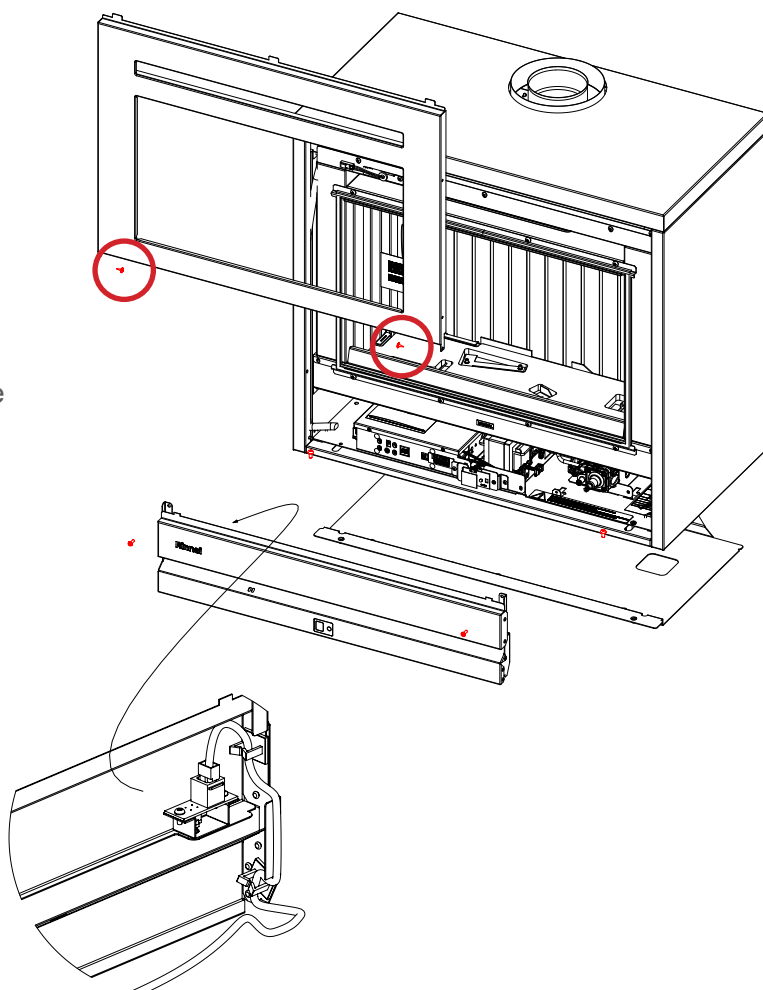

Test operation and lighting sequence

It may take approximately two hours of operation for the burn media to achieve their full flame pattern and glow. During the initial burning in period, some smoke and smell may be experienced. The appliance should run on the high setting in a well ventilated room until these dissipate. It is important to check the flame pattern during this time.

Abnormal flame pattern

Abnormal flame performance and/or pattern can indicate a problem with your fire, such as blocked gas injectors, or that the burn media has shifted. There are some warning signs that could indicate a problem.

- Unusual smell from the appliance
- Continued difficulty or delay in establishing a flame
- Flame appears either very short or very long
- Flame only burns part way across the burner
- Severe soot building up on the inside of the glass

Important

It is the responsibility of the installer to check that under normal conditions of the appliance, all flue gases are exhausted to the outside atmosphere, and that there is no spillage of combustion gases into the room.

If the appliance cannot be made to perform correctly please contact Rinnai.

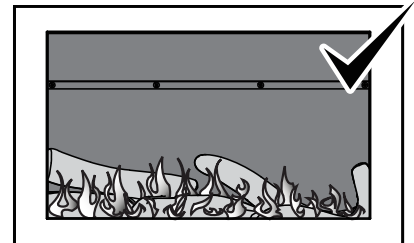

Normal flame pattern

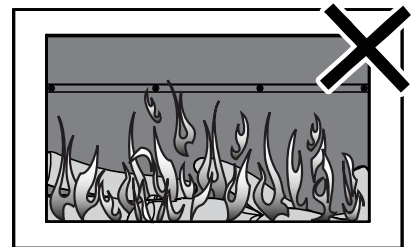

Abnormal flame pattern

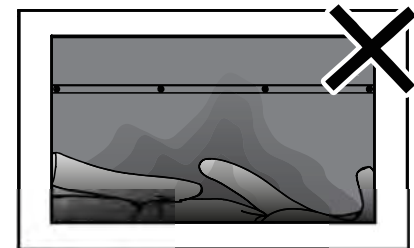

Soot build up

Installation checklist and customer handover

Complete the installation checklist in the customer operation guide, and make sure you leave the guide with the customer. Take the time to explain to the customer about the use and care of the unit, and that they understand the instructions.



Wiring diagram (part of commissioning)

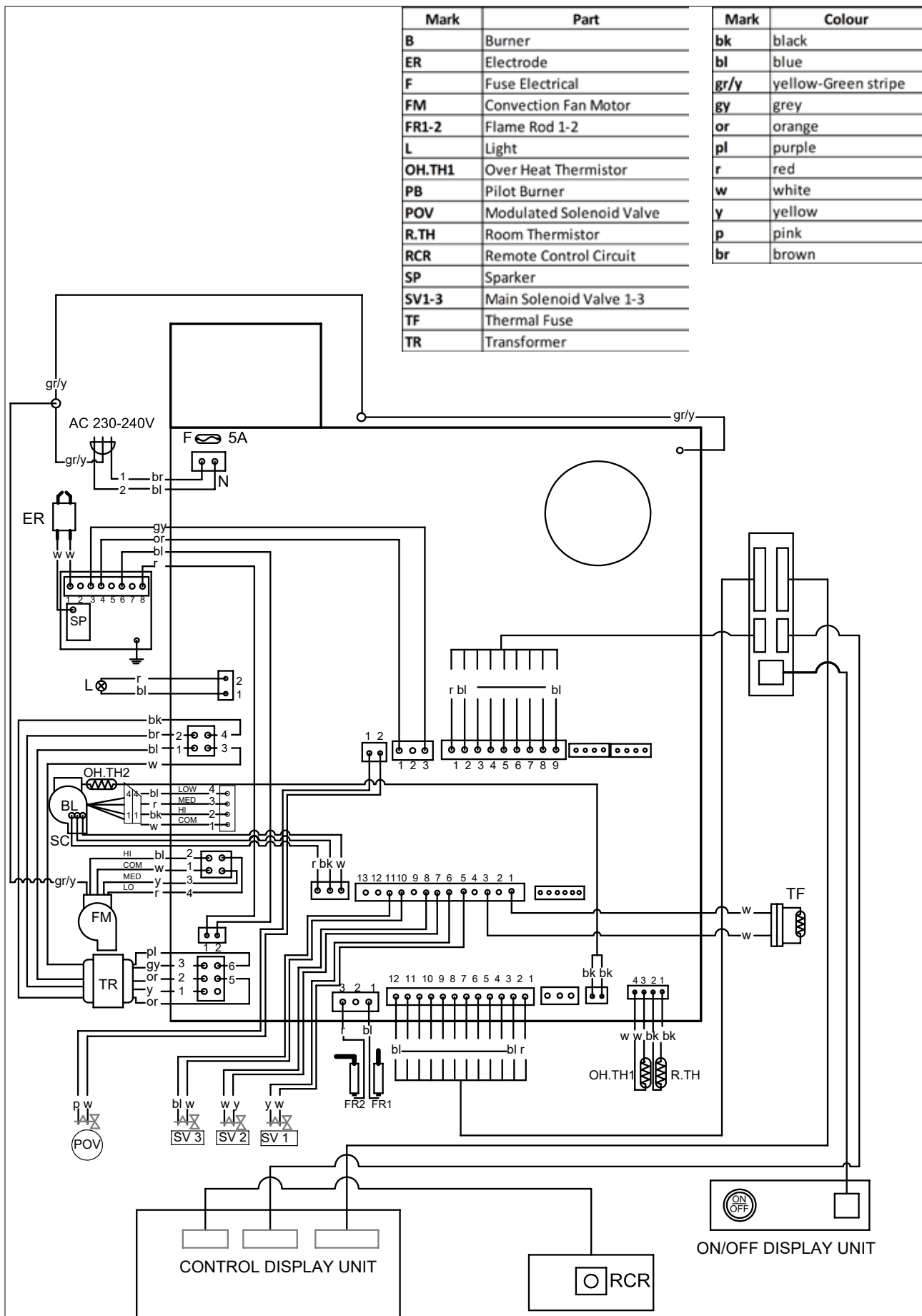

Novo flueing

Every gas fire requires a flue system that will draw effectively and clear flue products safely under all potential wind and climatic conditions. It is the responsibility of the installer to ensure the appliance is provided with an effective flue.

Some guidelines to assist with flue design are detailed in this guide. These must be read and modified as necessary depending on the installation. The Novo must be installed with an approved flue system, approved components are shown in this guide.

General flueing guidelines

Self-supporting flue

The painted sections of the flue are supported by the fire in the event of the fire needing to be removed for maintenance, servicing etc. The rest of the flue system should not be supported by the appliance—it should be self-supporting. This is done with flue supports or straps within the roof cavity. Wall straps have been included in the Rinnai vertical flue kits. Elbow straps are also available as a separate component to prevent excess weight on the flue elbow.

Flue terminal locations

Flue terminals must be compliant with the flue terminal locations shown in AS/NZS 5601.1. The flue cannot terminate under a floor or in a roof space.

Shared flues

Gas appliances must not be connected to a chimney or flue serving a separate flue burning appliance.

Flashings

Flashings are not included in the flue kits. Flashings must comply with E2, this is the responsibility of the installer.

Flue cowl clearance

To ensure products of combustion are cleared, adequate clearance from the building is required.

The flue cowl should have a 500 mm clearance from any part of the building. This also applies to steeped and pitched roofs where the flue cowl should be 500 mm clear of the ridge line.

An adequate flow of fresh air must exist around the flue cowl following installation.

Minimum clearances are shown in AS/NS 5601.1

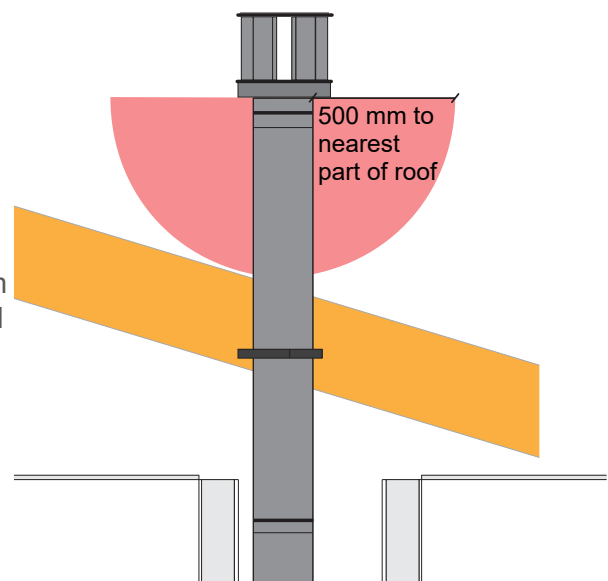

Novo Freestanding flueing options

Minimum flue length

This is required to ensure adequate draw and to prevent spill-back of combustion products, which can cause the safety sensors to shut down the fire.

- Min. vertical length: 3 m
- Min. flue length before any bends or offsets: 900 mm (or one length of flue)

Maximum flue length

The maximum flue length is determined by what the product has been tested, verified, and certified to.

- Max. flue length: 8 m
- Max. number of bends: 2 x 45°, or 2 x 90°

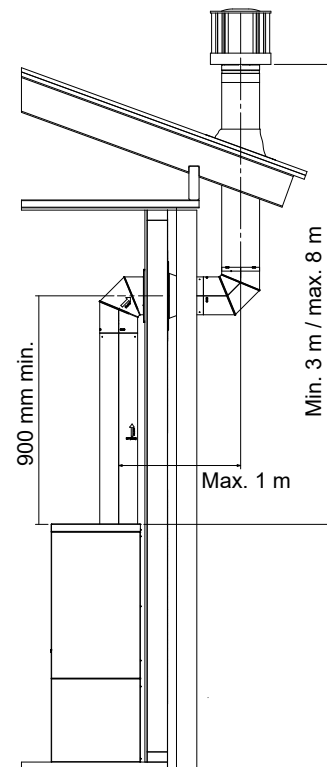
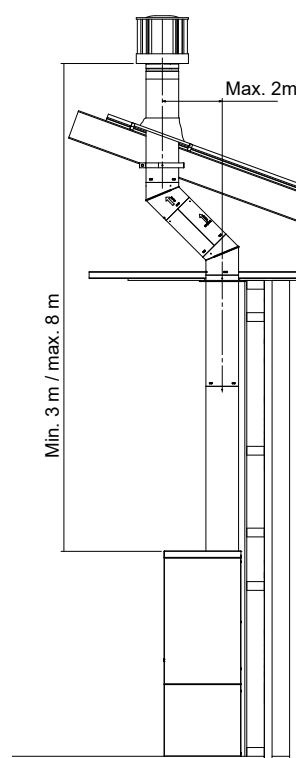
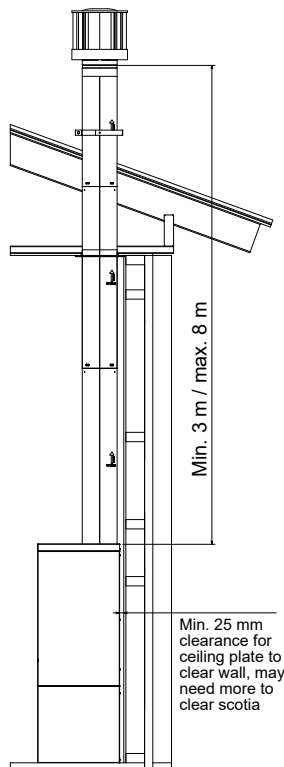

Freestanding straight vertical

For this option we have a standard single storey vertical flue kit 3.6 m, refer p. 31. If flueing is longer individual flue components can be purchased.

Visible flue sections are powder coated in galaxy black.

Freestanding vertical offset

This option uses 45° bends to offset obstructions in the roof space.

Individual flue components need to be purchased for this option.

Freestanding vertical with a 90° offset wall penetration

For instances where there may be another room above or vertical obstructions. There is also an option to penetrate the wall with 45° bends.

Individual flue components need to be purchased for this option.

Novo freestanding flueing overview

General installation information

The flue is built from the bottom up. The galaxy black sections of the flue are supported by the fire in the event of the fire needing to be removed for maintenance, servicing etc. The pipes are interlocking. Use of sealant is optional.

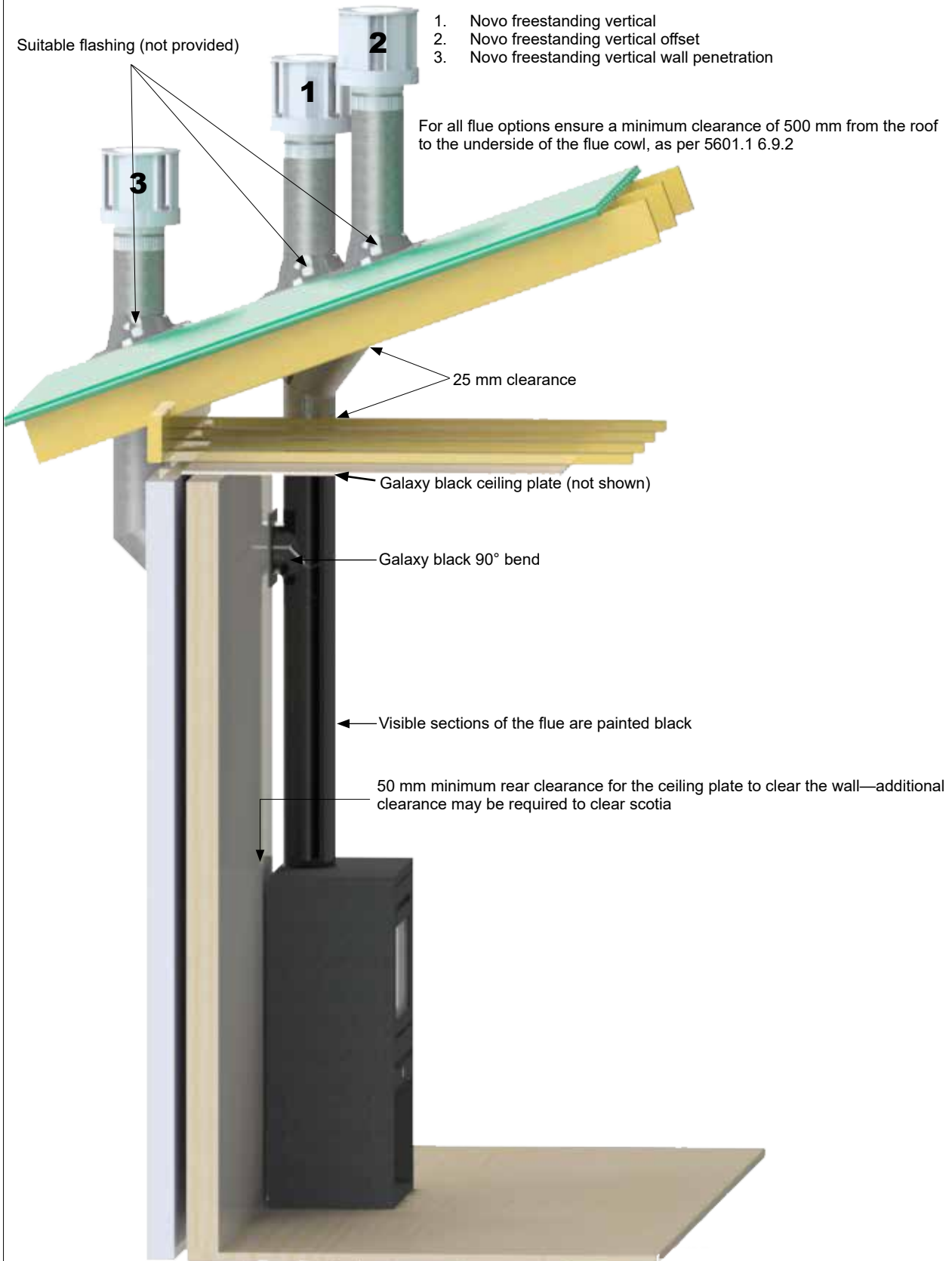

Novo freestanding flue kits and components

R3706: Novo freestanding flue kit DV black 3.6 m

Galaxy black powder coated freestanding flue kit. Contains:

- R3636: 1 x 1200 mm flue pipe unpainted
- R3636GL: 2 x 1200 mm flue pipe black
- R3651: Coaxial flue cowl
- R3609GL: Cover plate black
- R3647: 2 x wall straps

Flue pipes cannot be cut to size. Once joined the nominal length reduces approximately 35 mm.

- Inner: Aluminium (Ø100 mm)
- Outer: Galvanised steel (Ø170 mm)

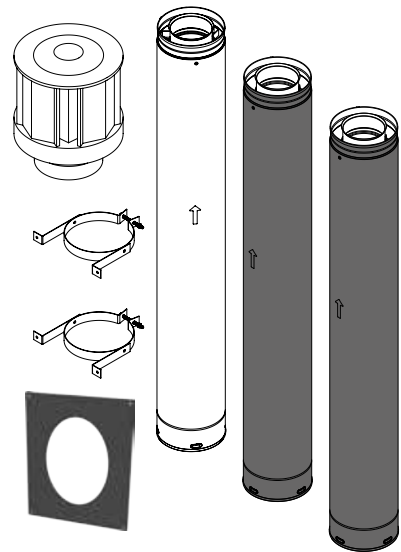

UNPAINTED DV coaxial flue pipes

Interlocking pipe used to construct vertical flueing. CANNOT be cut to size. Once joined nominal length reduces approximately 35 mm.

- Inner: Aluminium (Ø100 mm)
- Outer: Galvanised steel (Ø170 mm)

Pipe	Installed length	Code
150 mm	114 mm	R3630
230 mm	191 mm	R3631
300 mm	267 mm	R3632
450 mm	419 mm	R3633
600 mm	572 mm	R3634
900 mm	876 mm	R3635
1200 mm	1181 mm	R3636



PAINTED DV coaxial flue pipes

Interlocking pipe used to construct vertical flueing. CANNOT be cut to size. Once joined nominal length reduces approximately 35 mm.

- Inner: Aluminium (Ø100 mm)
- Outer: Galvanised steel (Ø170 mm) powder coated black

Pipe	Installed length	Code
150 mm	114 mm	R3630GL
230 mm	191 mm	R3631GL
300 mm	267 mm	R3632GL
450 mm	419 mm	R3633GL
600 mm	572 mm	R3634GL
900 mm	876 mm	R3635GL
1200 mm	1181 mm	R3636GL



Novo freestanding flue components

Coaxial vertical flue cowl

Code: R3651

Aluminium flue terminal required for all coaxial vertical flue installations—part of all vertical flue kits.

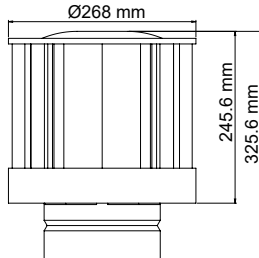

DV flue pipe extensions unpainted, and painted

75-175 mm: R3638 (unpainted) R3638GL (painted)
75-360 mm: R3639 (unpainted) R3639GL (painted)

Used for extended straight lengths of flue. Available in two lengths—extending to 175 mm or 360 mm. CANNOT be cut to size. Painted variants are powder coated black.

Inner: Aluminium Ø100 mm

Outer: Galv. steel Ø170 mm

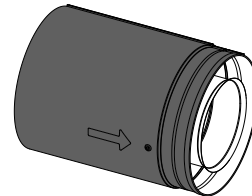
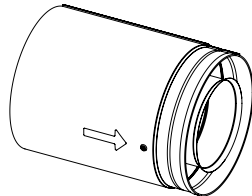

Coaxial 45° flue elbows (two bends in a kit)

Codes: R3642 (unpainted) R3642GL (painted, powder coated black)

Offsets obstructions. Elbow swivels 360° at base. Angle not adjustable. Once joined effective length reduces 35 mm to approx. 73 mm.

Inner: Aluminium Ø100 mm

Outer: Galv. steel Ø170 mm

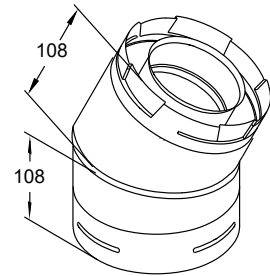

Coaxial 90° flue elbow unpainted, and painted

Codes: R3643 (unpainted) R3643GL (painted, powder coated black)

Used to facilitate between vertical and horizontal flueing. Elbow swivels at base. Angle not adjustable. Once joined effective length reduces 35 mm to approx. 130 mm.

Inner: Aluminium Ø100 mm

Outer: Galv. steel Ø170 mm

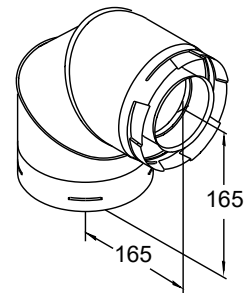

45° black plate

Code: R3608GL

Galaxy black 45° plate to cover/tidy hole where flue pipe penetrates, used in offset installations.

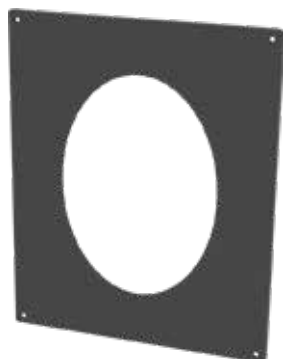

Cover plate black

Code: R3609GL

Galaxy black ceiling/wall plate to cover/tidy hole where flue pipe penetrates.

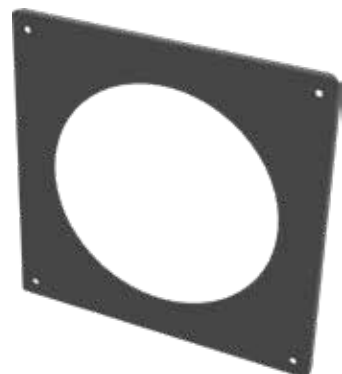

Elbow flue strap DV

Code: R3644

Flue supports for elbows and offsets. Strap length approximately 432 mm.

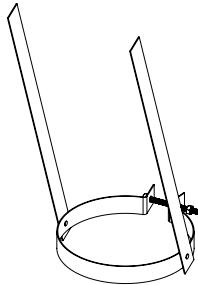

Wall strap DV

Code: R3647

Adjustable strap used in installations to add lateral support to the flue. Provides a 50-200 mm clearance to combustibles.

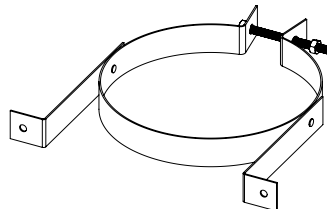

High wind vertical cowl protection kit

Code: R3655

For windy areas such as Wellington, coastal properties, and elevated properties on hills. Designed to wrap around the vertical cowl (as pictured) to reduce wind entering the flue and causing disturbances. It is fitted to the cowl, and can be retrofitted.

Construction - stainless steel

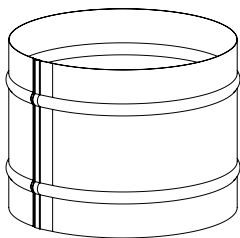

45° bend offset / rise dimensions

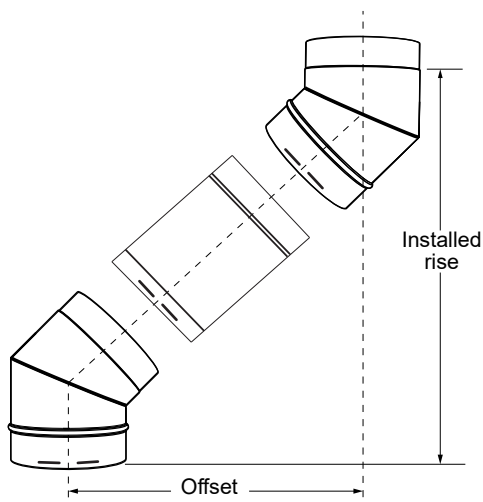

Flue pipe (length and code)	Offset	Installed rise
None (bend to bend)	N/A	124 mm
150 mm	R3630	203 mm
230 mm	R3631	257 mm
300 mm	R3632	311 mm
450 mm	R3633	417 mm
600 mm	R3634	524 mm
900 mm	R3635	737 mm
1200 mm	R3636	949 mm

Appendix: Material selection calculations

The following information and table is supplementary to the information provided on pages 8-9. The information provides further detail on the relationship between various clearance dimensions and gives examples of what specific dimensions can be if other clearances are tweaked.

Dim. Description	Material temperature rated above ambient	
	Materials rated to a max. of 50 °C	Unrated materials, up to a max. of 20 °C
A Overhang	<ul style="list-style-type: none"> Not suitable if B is under 250 mm No restrictions if B is greater than 1000 mm <p><u>If B is 300-1000 mm then the calculation is: $A = B - 250$</u> If B = 300 A = 300-250, the overhang can be 50 mm max. If B = 350 A = 350-250, the overhang can be 100 mm max. If B = 400 A = 400-250, the overhang can be 150 mm max. If B = 450 A = 450-250, the overhang can be 200 mm max.</p>	
B Clearance above	100 mm min. If recessed with an overhang $B = A + 250$	200 mm min If recessed with an overhang $B = A + 250$
	If A = 50 B = 50+250, clearance above needs to be 300 mm min. If A = 100 B = 100+250, clearance above needs to be 350 mm min. If A = 150 B = 150+250, clearance above needs to be 400 mm min. If A = 200 B = 200+250, clearance above needs to be 450 mm min.	
C Side overhang	No restrictions if D is greater than 400 mm <u>If D is less than 400 mm, $C = D + 50$</u> C = 50 +50, side overhang 100 mm max. C = 100+50, side overhang 150 mm max. C = 150+50, side overhang 200 mm max. C = 200+50, side overhang 250 mm max.	No restrictions if D is greater than 400 mm <u>If D is less than 400, $C = D$</u> C = 50, side overhang 50 mm max. C = 100, side overhang 100 mm max. C = 150, side overhang 150 mm max. C = 200, side overhang 200 mm max.
D Side clearance	50 mm min. No restrictions if D is greater than 400 mm <u>$D = C - 50$</u> 150-50, side clearance must be 100 mm min. 200-50, side clearance must be 150 mm min. 250-50, side clearance must be 200 mm min. 300-50, side clearance must be 250 mm min. 350-50, side clearance must be 300 mm min. 400-50, side clearance must be 350 mm min.	100 mm min. No restrictions if D is greater than 400 mm <u>$D = C$</u> 150, side clearance must be 150 mm min. 200, side clearance must be 200 mm min. 250, side clearance must be 250 mm min. 300, side clearance must be 300 mm min. 350, side clearance must be 350 mm min. 400, side clearance must be 400 mm min.

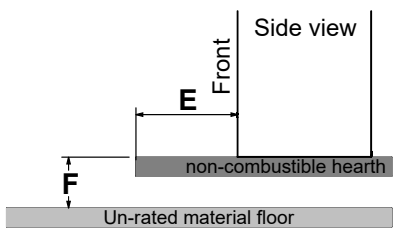
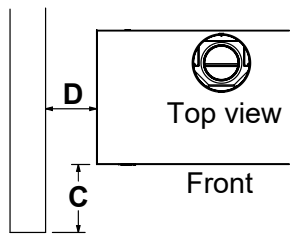
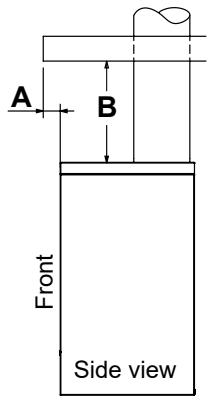

In this case, F can be reduced using
 $F = 450 - E$ mm min.

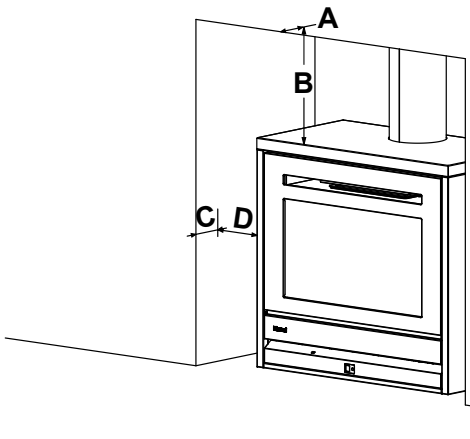

A = 100, so
 B = 350 (A + 250)
 C = 100, so
 D = 50 (C-50)

Rinnai.co.nz

Tel: 0800 746 624
<http://www.youtube.com/rinnainz>
<http://facebook.com/rinnainz>

Novo freestanding installation guide 13992-E