

1000L
(MSX1000)

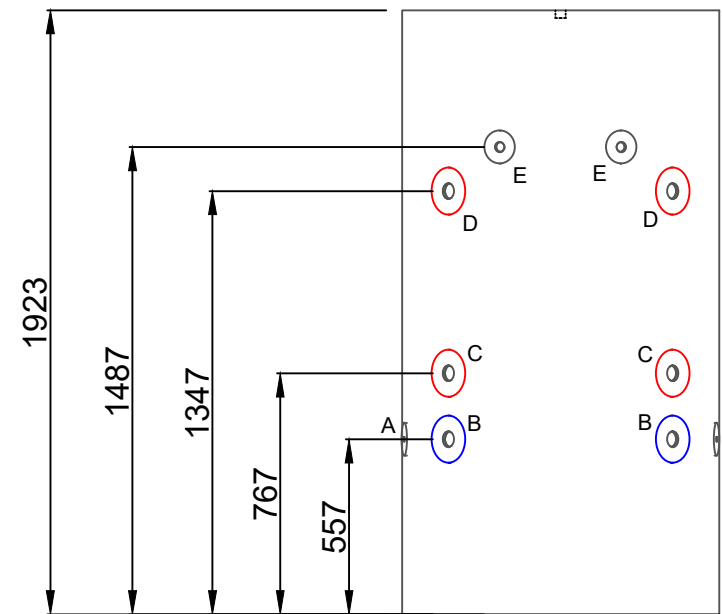

800L
(MSX0800)

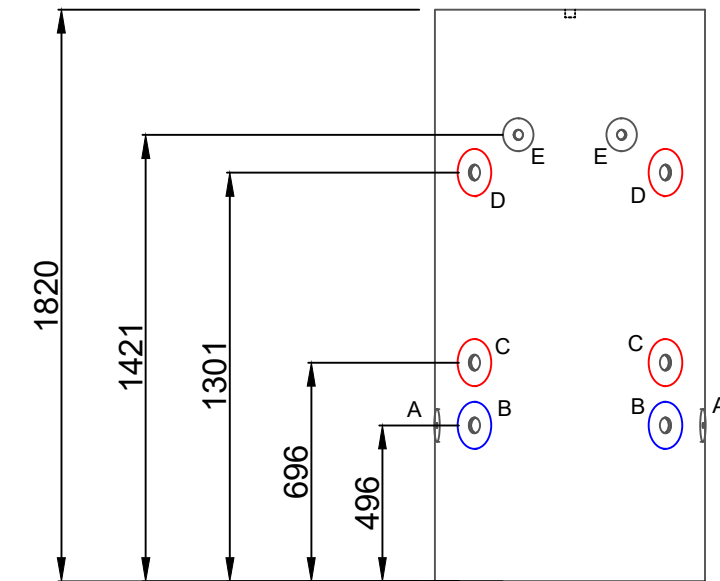

500L
(MSX0500)

Standard Connection Sizes

(A)	Sensor Pocket	DN15	½" BSP female
(B)	Cold Water Inlet	DN50	2" BSP female
(C)	Secondary Return	DN50	2" BSP female
(D)	Hot Water Outlet	DN50	2" BSP female
(E)	TPR	DN32	1¼" BSP female

Specifications

Pressure Rating	1200 kPa		
Water Pressure	TPR	1000 kPa	Supplied
	PLV	1000 kPa (approx.)	NOT SUPPLIED
	PRV (Cold Water)	700 kPa (approx.)	NOT SUPPLIED
Heat Loss 24 hrs @ 65°C	500L	800L	1000L
Weights empty	99 kg	153 kg	178 kg
	Weights full	599 kg	953 kg

Load Restraint (NZS4219:2009)

	500L	800L	1000L
Weight Calculation	5.9kN	9.3kN	11.5kN
Lateral Force on Tank	10.56kN	16.81kN	20.69kN
Load Demand Coefficient	1.8	1.8	1.8

Rinnai NZ Limited
105 Pavilion Drive
Mangere, Auckland
2022

XL Commercial Cylinders

Designed:	Spec #:
Drawn: EP	Date:
Scale @ A3:	Rev:
Scale @ A4:	