

# Infinity V16 (REU-V1616W) external water heater

This diagram is provided to assist you to identify parts if replacement is necessary. Contact your place of purchase or the manufacturer to enquire about parts, availability and/or service.

Ref.	Description	Qty.	Part No.
001	Front panel	1	4882
002	Wall bracket	2	3387
803	Screw pack for front panel	1	R5040

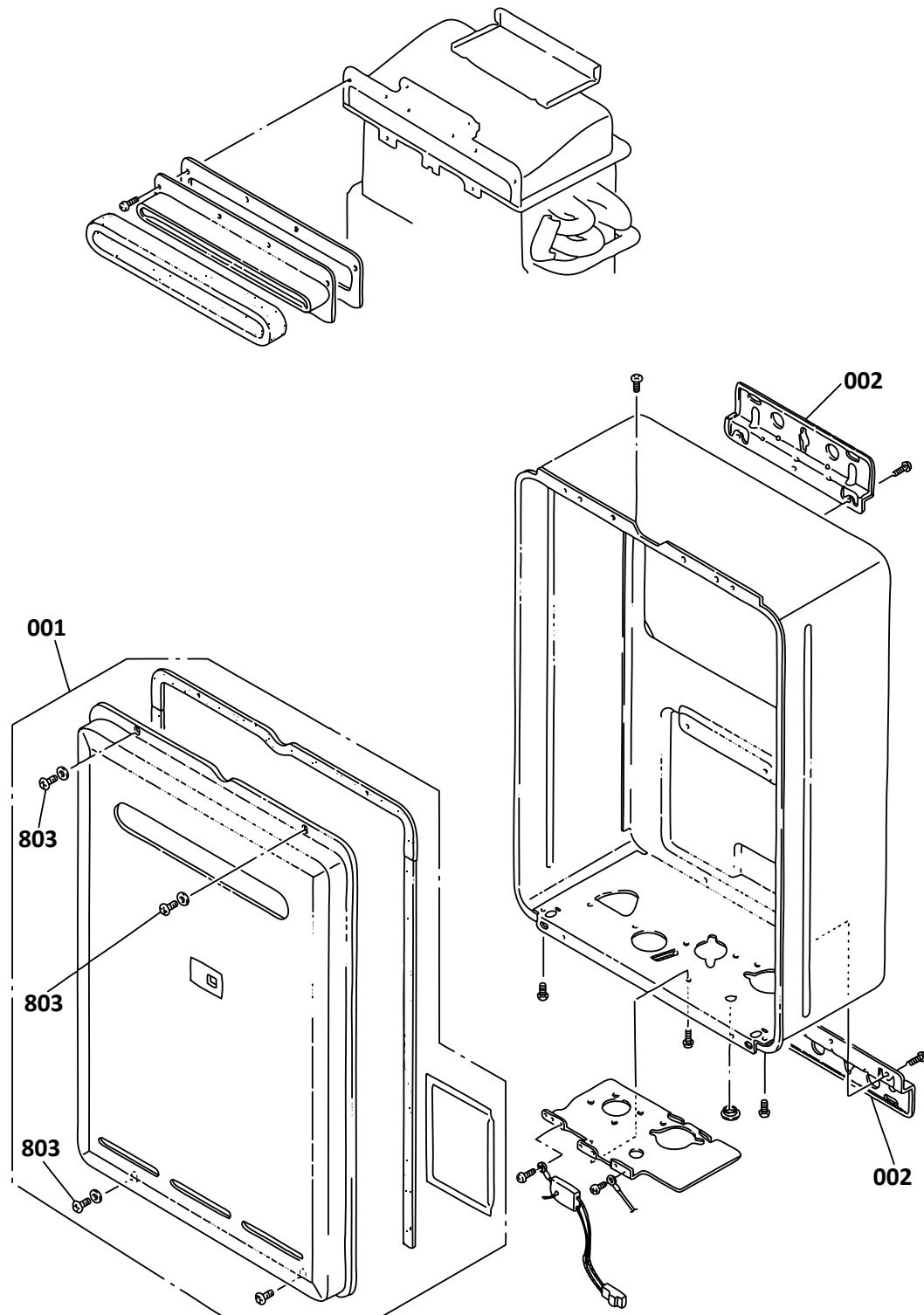

# Infinity V16 (REU-V1616W) external water heater

This diagram is provided to assist you to identify parts if replacement is necessary. Contact your place of purchase or the manufacturer to enquire about parts, availability and/or service.

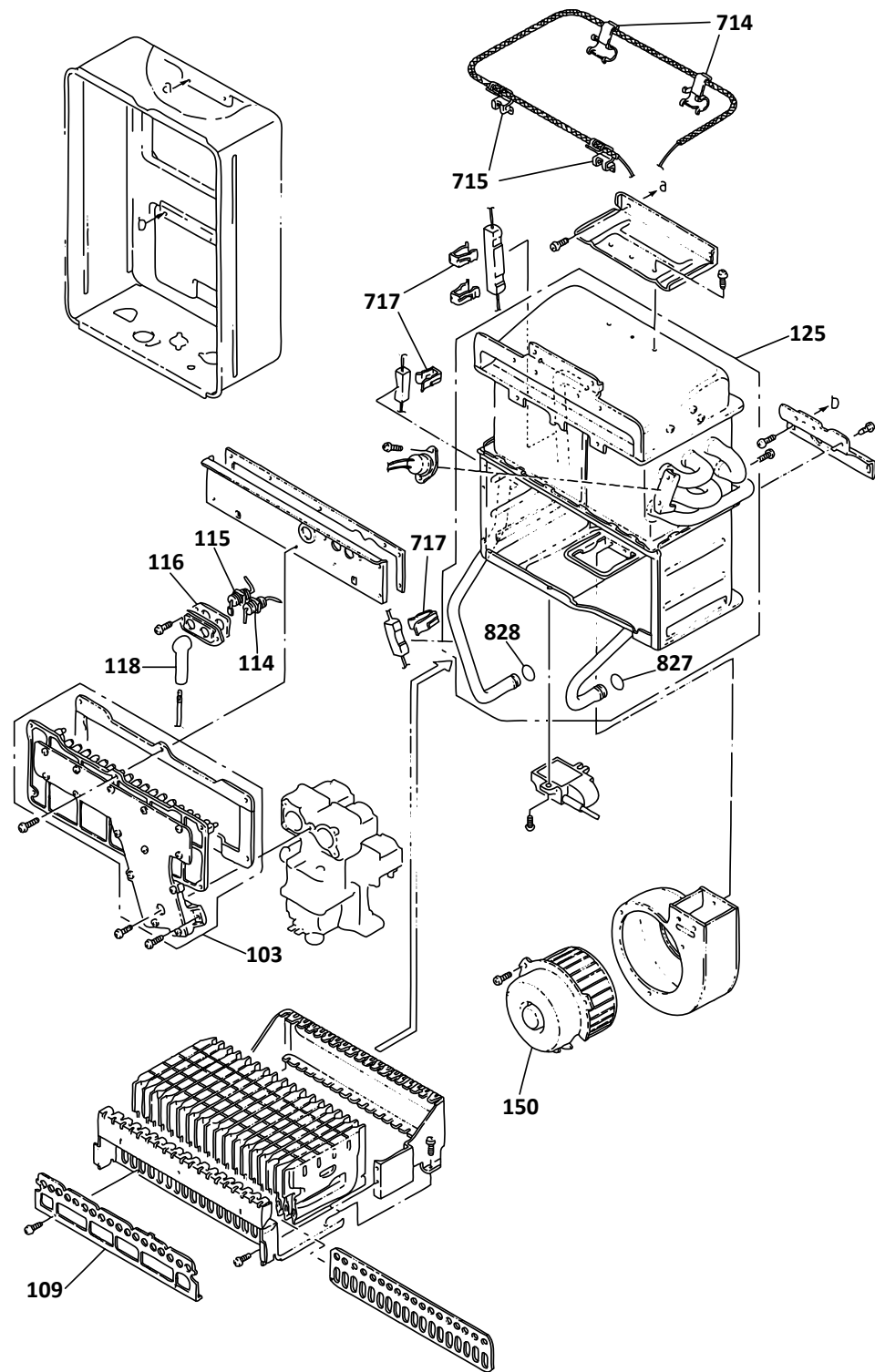

Ref.	Description	Qty.	Part No.
103	Manifold assembly LPG	1	4885
103	Manifold assembly NG	1	4886
109	Damper LPG	1	4889
114	Electrode	1	3445
115	Flame rod	1	4916
116	Electrode packing	1	3465
118	Electrode sleeve	1	3475
125	Heat exchanger	1	4919
150	Fan motor assembly	1	5782
714	Thermal fuse fixing plate	2	3659
715	Thermal fuse fixing plate	2	4899
717	Heater mounting bracket	4	2032
827	O-ring	1	4912
828	O-ring	1	3826

# Infinity V16 (REU-V1616W) external water heater

This diagram is provided to assist you to identify parts if replacement is necessary. Contact your place of purchase or the manufacturer to enquire about parts, availability and/or service.

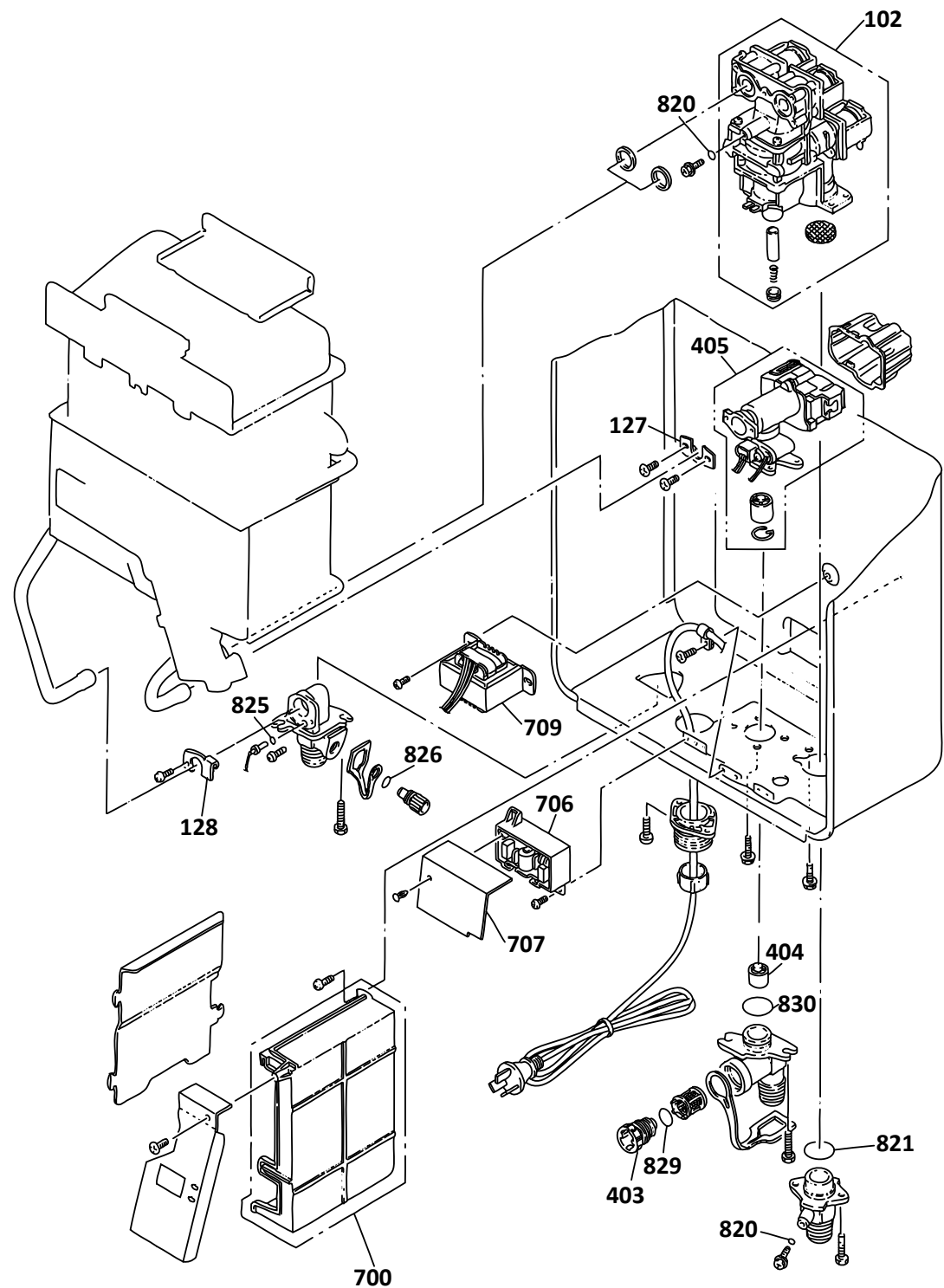

Ref.	Description	Qty.	Part No.
102	Gas control assembly	1	4884
127	Bracket for holding water pipe	1	3331
128	Bracket for holding water pipe	1	3332
403	Incoming water filter (filter + plug)	1	3839
404	Turbine	1	3487
405	Water flow servo & sensor assembly	1	3330
700	PCB	1	4926
706	Surge protector	1	4930
707	Surge protector cover	1	4931
709	Transformer	1	4892
820	O-ring	2	2239
821	O-ring	1	3387
825	O-ring	1	3832
826	O-ring	1	1031
829	O-ring	1	1244
830	O-ring	1	3627

# Infinity V16 (REU-V1616W) external water heater

This diagram is provided to assist you to identify parts if replacement is necessary. Contact your place of purchase or the manufacturer to enquire about parts, availability and/or service.

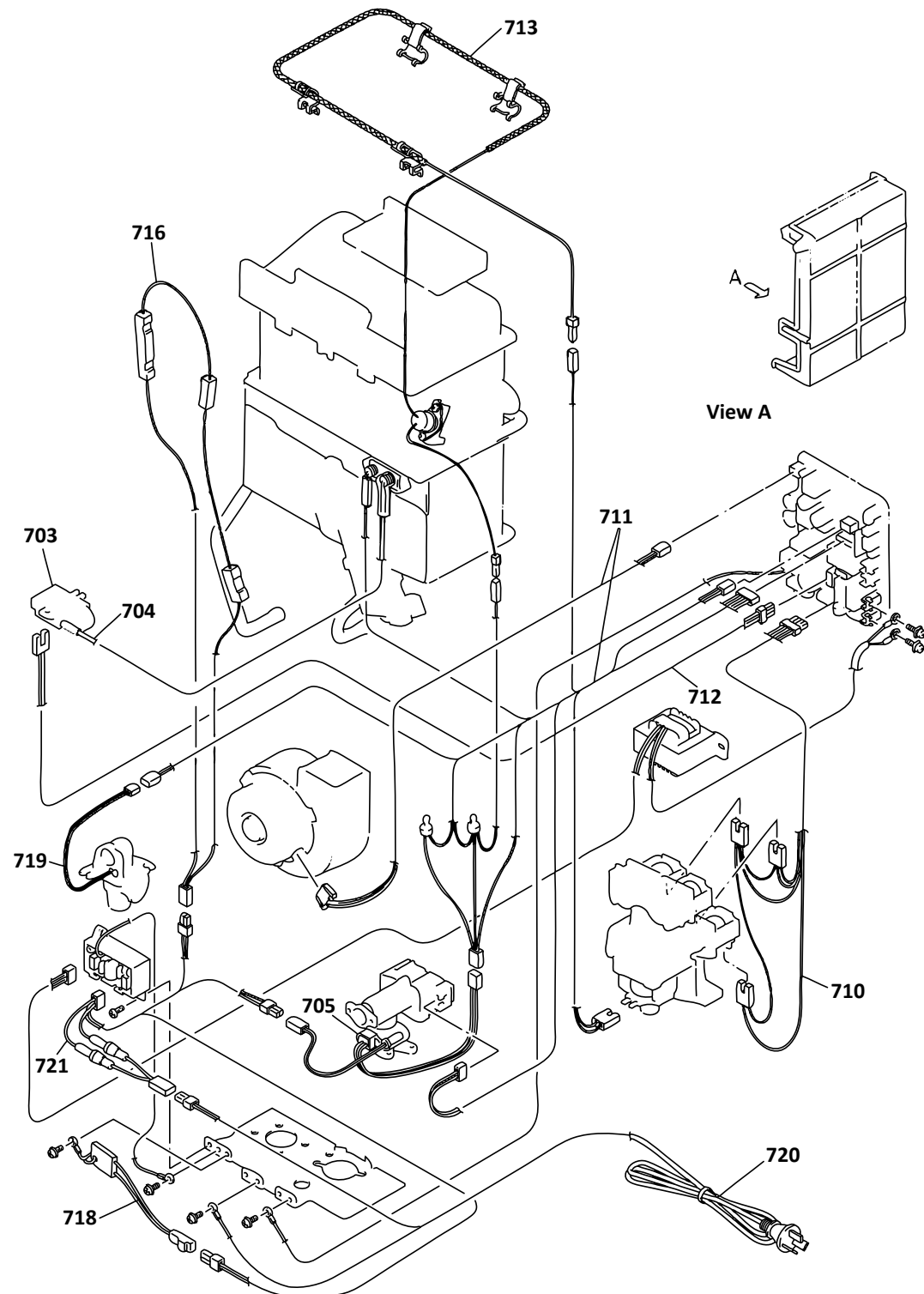

Ref.	Description	Qty.	Part No.
703	Sparker	1	4927
704	High tension lead	1	3651
705	Frost sensing switch	1	3358
-	230 V anti frost heater	1	3327
710	Solenoid valve harness	1	4893
711	Sensor harness	1	4894
712	Sparker harness	1	4895
713	Thermal fuse assembly	1	4896
716	230 V anti frost heater	1	4900
718	Frost sensing switch	1	3358
719	Thermistor	1	3389
720	Power lead	1	3526
721	Fuse harness NG	1	4905
721	Fuse harness LPG	1	4906
-	Anti frost kit	1	FROST5