

Rinnai

GAS APPLIANCES

Portable Gas Barbecue

Operating and assembly instructions

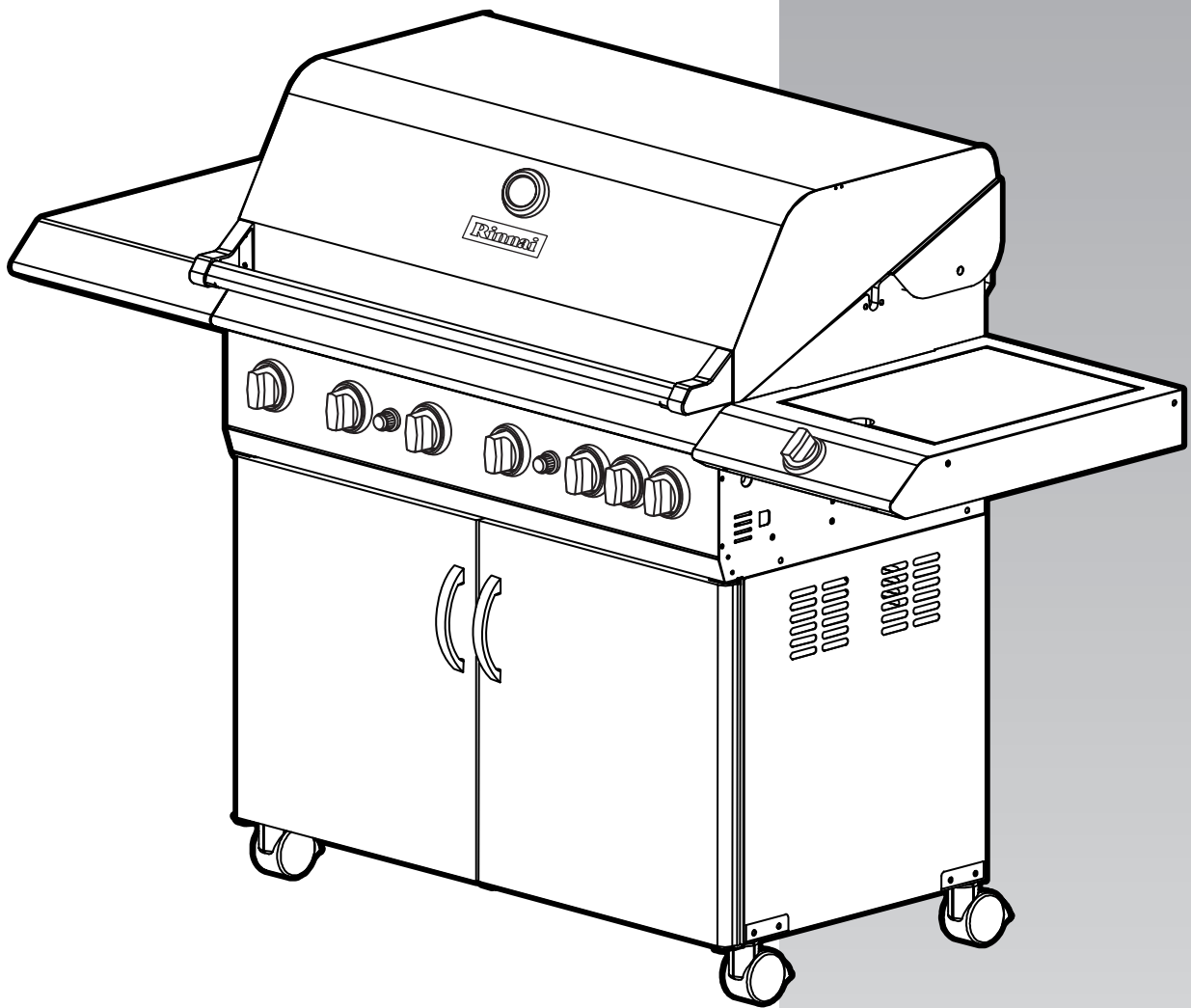

FOR YOUR SAFETY.

IF YOU SMELL GAS:

1. Shut off gas to the appliance, if possible.
2. Extinguish any open flame.
3. Open hood.
4. If odour continues, immediately call your gas supplier or fire department.

FOR YOUR SAFETY.

1. Do not store or use petrol or other flammable vapours and liquids in the vicinity of this or any other appliance.
2. A gas cylinder not connected for use must not be stored in the vicinity of this or any other appliance.

These instructions are a guide to assembling and using the Alfresco barbecue.

Please read carefully and retain for future reference.

Only to be used outdoors.
Illustration may vary from barbecue contained in carton.



FAILURE TO COMPLY WITH THESE INSTRUCTIONS COULD RESULT IN A FIRE OR EXPLOSION WHICH COULD CAUSE SERIOUS BODILY INJURY, DEATH OR PROPERTY DAMAGE.

TABLE OF CONTENTS

General	2
Safety	3
Outdoor Areas	4
Pre-Assembly	5
Assembly	6-11
Inspection	12-13
Accessory Assembly	13
Operation	14-16
Fault Finding	17
Maintenance	18-20
Parts Diagram and Lists	22-23

FOR CUSTOMER REFERENCE

(Record and file in a safe place)

Purchased from _____

Date purchased _____

Serial No. _____

NOTE: Sales docket must be kept as proof of purchase date.



ACCESSIBLE PARTS MAY BE VERY HOT. KEEP YOUNG CHILDREN AWAY. ANY MODIFICATION OF THIS APPLIANCE MAY BE DANGEROUS. DO NOT MOVE THIS APPLIANCE DURING USE. TURN OFF THE GAS SUPPLY AT THE GAS CYLINDER AFTER USE. READ THE INSTRUCTIONS BEFORE USING THE APPLIANCE. PARTS SEALED BY THE MANUFACTURER MUST NOT BE MANIPULATED. THIS BARBECUE IS ONLY TO BE USED OUTDOORS. NEVER OPERATE THIS BARBECUE WITHOUT A REGULATOR.

SPECIFICATIONS

Appliance specifications can be found on the data label attached to the rear panel of the barbecue body.

GAS INSTALLATION CODES

Barbecues must be used in accordance with the installation requirements of your local gas supply authority, and the appropriate installation standard AS5601/AG601.

Barbecues for use with bottled gas are labelled 'Universal LPG'. Barbecues for use with natural gas are labelled 'Natural Gas' and must be installed by a qualified person. Check the gas type sticker attached to the barbecue. Check that the label matches the gas type to be used.

DIMENSIONS AND CLEARANCES

Height – hood closed 1235 mm, hood open 1605 mm

Width – 1840 mm

Depth – hood closed 660 mm, hood open 785 mm

Openings at the rear and sides of the appliance provide air for combustion, and must not be obstructed.

Minimum clearances from combustible materials must be maintained: top and rear – 800 mm, sides – 250 mm, bottom of firebox – 300 mm (*inbuilt model*).

HOSE CONNECTIONS

5/8"-18 UNF (3/8" SAE FLARE).

HOSE AND REGULATOR SAFETY

The regulator and hose assembly supplied with the barbecue is suitable for use with bottled gas – POL connection.

A gas regulator adjusted to have an outlet pressure of 2.75 kPa is supplied for connection to the gas cylinder. The regulator and hose assembly supplied with the appliance must be used. Replacement regulator and hose assemblies must be those specified by the appliance manufacturer.

When connecting the hose and regulator assembly to the gas cylinder, take care to avoid unnecessary twisting of the flexible hose. After the assembly has been secured, turn on the gas and check for leaks by brushing a soap and water solution over all visible and accessible gas line connections. The presence of bubbles will indicate a gas escape. **DO NOT TEST FOR GAS ESCAPES WITH AN OPEN FLAME.**

If you are unable to correct the leak by tightening the connection, turn off the gas and contact your place of purchase immediately.

Always ensure the appliance is kept away from flammable materials and the gas cylinder clear of any heat source.

When changing over from an empty gas cylinder to a full one, make sure this procedure is carried out in a flame free atmosphere.

Inspect the gas hose when replacing the gas cylinder or once a year whichever is more frequent. If the hose is cracked, cut, abraded or damaged in any way, the appliance must not be operated. The hose must be replaced if damaged or when statutory conditions require it. Contact your place of purchase if uncertain.

The POL fitting of the hose and regulator should be disconnected from the gas cylinder valve when the outdoor appliance is not in use.

NATURAL GAS INSTALLATION

This barbecue is also certified for use on natural gas. It must be converted and installed by a qualified person if not provided in the correct condition for use on natural gas. Contact your place of purchase for advice in relation to using your barbecue on natural gas if not already provided in natural gas specification.



READ CAREFULLY BEFORE ASSEMBLING AND OPERATING YOUR BARBECUE.

LOCATION OF YOUR BARBECUE

DO NOT use your barbecue in garages, porches, breezeways, sheds or other enclosed areas. Your barbecue is to be used **OUTDOORS ONLY**. Refer to page 5. The barbecue is not intended to be installed in or on recreational vehicles and/or boats and should not be placed under any surface that will burn. Do not obstruct the flow of combustion and ventilation air around the barbecue while in use.



FOR YOUR SAFETY:

DO NOT STORE OR USE PETROL OR OTHER FLAMMABLE VAPOURS AND LIQUIDS IN THE VICINITY OF THIS OR ANY OTHER APPLIANCE.

DO NOT STORE EMPTY OR FULL SPARE GAS CYLINDERS IN STORAGE COMPARTMENT OR NEAR THIS OR ANY OTHER APPLIANCE.

KEEP THE GAS HOSE AWAY FROM HOT SURFACES. PROTECT GAS HOSE FROM DRIPPING GREASE.

AVOID UNNECESSARY TWISTING OF HOSE. VISUALLY INSPECT HOSE PRIOR TO EACH USE FOR CUTS, CRACKS, EXCESSIVE WEAR OR OTHER DAMAGE. REPLACE HOSE, IF NECESSARY.

NEVER TEST FOR GAS LEAKS WITH A LIT MATCH OR OPEN FLAME.

NEVER LIGHT BARBECUE WITH HOOD CLOSED.

NEVER LEAN OVER COOKING SURFACE WHILE LIGHTING BARBECUE.

USE GOOD QUALITY INSULATED OVEN MITTS WHEN OPERATING BARBECUE.

NEVER ALTER OR MODIFY THE REGULATOR OR GAS SUPPLY ASSEMBLY. THIS BARBECUE MUST NOT BE USED INDOORS.



IF YOU SMELL GAS:

1. **SHUT OFF GAS TO THE APPLIANCE AT ITS SOURCE, IF POSSIBLE.**
2. **EXTINGUISH ANY OPEN FLAME.**
3. **OPEN HOOD.**
4. **PERFORM GAS LEAK CHECK PROCEDURE.**
5. **IF ODOUR CONTINUES, IMMEDIATELY CALL YOUR GAS SUPPLIER OR FIRE DEPARTMENT.**

PROTECT CHILDREN

Keep children away from barbecue during use and until barbecue has cooled after you are finished. Do not allow children to operate barbecue, or to swing on handle.

CHECKING FOR GAS LEAKS

NEVER TEST FOR LEAKS WITH AN OPEN FLAME.

Prior to first use, and at the beginning of each new season (or, if using bottled gas, whenever gas cylinder is changed), you must check for gas leaks.

Follow these steps:

1. Make soap solution by mixing one part liquid detergent and one part water.
2. Turn burner control(s) to 'OFF', then turn on gas at source.
3. Apply the soap solution to all visible and accessible gas connections. Bubbles will appear in the soap solution if connections are not properly sealed. Tighten or rectify as necessary.
4. If you have a gas leak you cannot rectify, turn off the gas at the source, disconnect hose from barbecue and immediately contact your place of purchase for assistance. Refer to page back cover.

GAS CYLINDER USE AND SAFETY

This is a low pressure barbecue and must only be used with the hose and regulator supplied.

Your barbecue is designed for use with a 9 kg gas cylinder. Ensure gas cylinder conforms to Australian standards.

DO NOT CONNECT YOUR BARBECUE TO A GAS CYLINDER LESS THAN OR EXCEEDING THIS CAPACITY.



NEVER CONNECT AN UNREGULATED GAS CYLINDER TO YOUR BARBECUE.

The gas cylinder should be filled by a reputable gas dealer, or exchanged at a reputable cylinder exchange outlet. Gas cylinders should be visually inspected and requalified periodically.

Always keep gas cylinder in an upright position. Always close the cylinder valve when the barbecue is not in use.

Do not subject gas cylinder to excessive heat.



NEVER STORE YOUR GAS CYLINDER INDOORS. FOR STORAGE AND CYLINDER EXCHANGE, DISCONNECT HOSE AT THE CYLINDER ONLY – DO NOT DISCONNECT HOSE FROM THE APPLIANCE.

If you store your barbecue indoors, ALWAYS disconnect and remove gas cylinder FIRST, and store gas cylinder safely outside. Gas cylinders must be stored outdoors in a well ventilated area out of reach of children, and must not be stored in a building, garage or any other enclosed area.



DANGER – IF YOU SMELL OR HEAR THE HISS OF ESCAPING GAS FROM THE GAS CYLINDER:

KEEP CLEAR OF THE GAS CYLINDER. DO NOT ATTEMPT TO CORRECT THE PROBLEM YOURSELF.

CALL YOUR FIRE DEPARTMENT (DO NOT MAKE THE CALL FROM ANYWHERE NEAR THE GAS CYLINDER – YOUR TELEPHONE IS AN ELECTRICAL DEVICE, AND COULD PRODUCE A SPARK).



THIS APPLIANCE SHALL ONLY BE USED IN AN ABOVE GROUND OPEN AIR SITUATION WITH NATURAL VENTILATION, WITHOUT STAGNANT AREAS, WHERE GAS LEAKAGE AND PRODUCTS OF COMBUSTION ARE RAPIDLY DISPERSED BY WIND AND NATURAL CONVECTION.

ANY ENCLOSURE IN WHICH THE APPLIANCE IS USED SHALL COMPLY WITH ONE OF THE FOLLOWING:

- AN ENCLOSURE WITH WALLS ON ALL SIDES, BUT AT LEAST ONE PERMANENT OPENING AT GROUND LEVEL AND NO OVERHEAD COVER
 - WITHIN A PARTIAL ENCLOSURE THAT INCLUDES AN OVERHEAD COVER AND NO MORE THAN TWO WALLS
 - WITHIN A PARTIAL ENCLOSURE THAT INCLUDES AN OVERHEAD COVER AND MORE THAN TWO WALLS, THE FOLLOWING SHALL APPLY:
 - (i) AT LEAST 25% OF THE TOTAL WALL AREA IS COMPLETELY OPEN; AND
 - (ii) AT LEAST 30% OF THE REMAINING WALL AREA IS OPEN AND UNRESTRICTED
 - IN THE CASE OF BALCONIES, AT LEAST 20% OF THE TOTAL OF THE SIDE, BACK AND FRONT WALL AREAS SHALL BE AND REMAIN OPEN AND UNRESTRICTED
 - DO NOT USE YOUR BARBECUE IN GARAGES, PORCHES, BREEZEWAYS, SHEDS OR OTHER ENCLOSED AREAS.
- YOUR BARBECUE IS TO BE USED OUTDOORS ONLY.
Refer below
- THE BARBECUE IS NOT INTENDED TO BE INSTALLED IN OR USED ON RECREATIONAL VEHICLES AND/OR BOATS AND SHOULD NOT BE PLACED ADJACENT TO OR UNDER ANY SURFACE THAT WILL BURN
 - DO NOT OBSTRUCT THE FLOW OF COMBUSTION AND VENTILATION AIR AROUND THE BARBECUE HOUSING WHILST IN USE.

The following diagrams are examples of outdoor areas.
These same principles apply to canopy or shaded cloth areas.

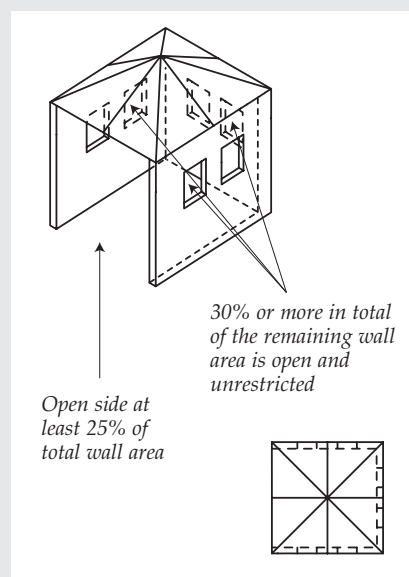
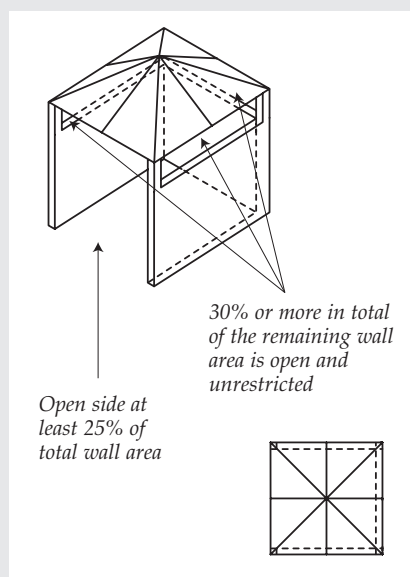
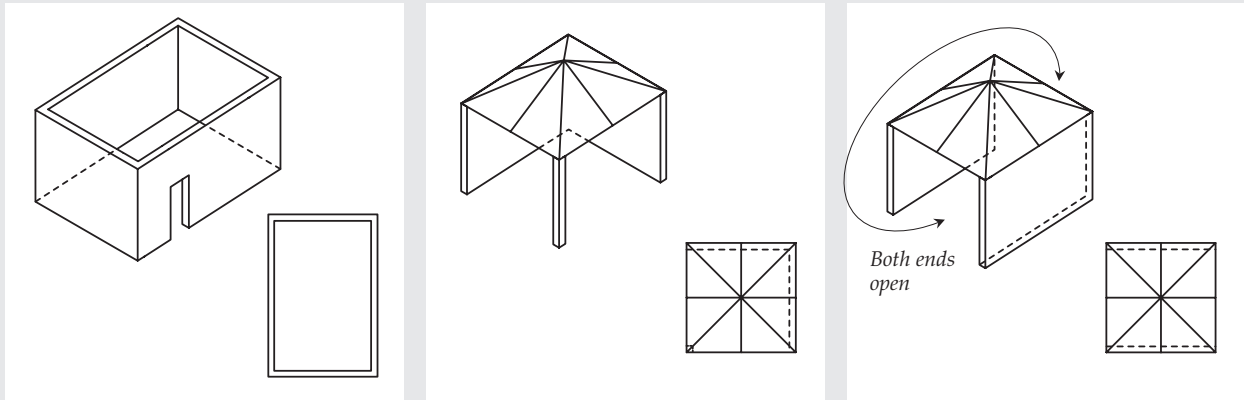

GENERAL

While it is possible for one person to assemble the barbecue, we recommend asking for the assistance of another person when manoeuvring some of the larger or heavier pieces.

ASSEMBLY TIPS

1. Flatten cardboard packaging and use this as a protective work surface to assemble upon.
2. Some protective coating may need to be removed from components prior to assembly.
3. Do not tighten screws and nuts until trolley is fully assembled.
4. Pre-screwing of connection points for securing the side shelves will assist in securing shelves smoothly.

CHECK BARBECUE FOR ANY DAMAGE

Before attempting to assemble your barbecue, check that all the necessary parts have been included using the parts list opposite. Inspect barbecue and trolley parts as you proceed.

Contact your place of purchase for assistance regarding replacement of any damaged or missing parts. Supplier contact details are on the back cover of the instruction manual.

Do not assemble or operate a barbecue that appears damaged.

Check that the barbecue supplied is correct for the gas type being used. There is a label on the side panel of the barbecue above the gas connection. Barbecues for use with gas cylinders are labelled 'Universal LPG'. Barbecues for use with natural gas are labelled 'Natural Gas'.

TOOLS YOU WILL NEED

Standard Phillips-head screwdriver.
Adjustable spanner (*open end shifter*).

CARTON CONTENTS

<i>Description</i>	<i>Qty</i>
Trolley side panel – <i>right</i>	1
Trolley side panel – <i>left</i>	1
Bottom shelf	1
Castor seat	4
Castors	4
Trolley bracket – <i>front</i>	1
Gas cylinder housing	1
Door hinge bracket – <i>top left</i>	1
Door hinge bracket – <i>top right</i>	1
Doors	2
Door guide	1
Door support bracket – <i>upper</i>	1
Barbecue body assembly	1
Side shelf – <i>left</i>	1
Side burner assembly – <i>right</i>	1
Shelf brackets – <i>A: LF/RR</i>	2
Shelf brackets – <i>B: RF/LR</i>	2
Hardware pack	1
Hot plate	1
Grill plate	4
Flame tamer	4



- PARTS AND COMPONENTS MUST NOT BE MODIFIED OR ALTERED IN ANY WAY. THIS COULD LEAD TO A HAZARDOUS SITUATION
- MODIFYING OR ALTERING ANY PARTS OR COMPONENTS WILL VOID THE WARRANTY.

- ① Attach castor seats to side panels.

NOTE: Castor seats are labelled for correct location

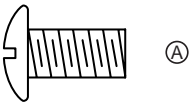

Phillips-head screw $1/4" \times 1/2"$
Qty: 8

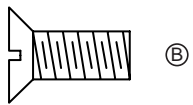

Countersunk flat-head screw $3/16" \times 3/8"$
Qty: 8

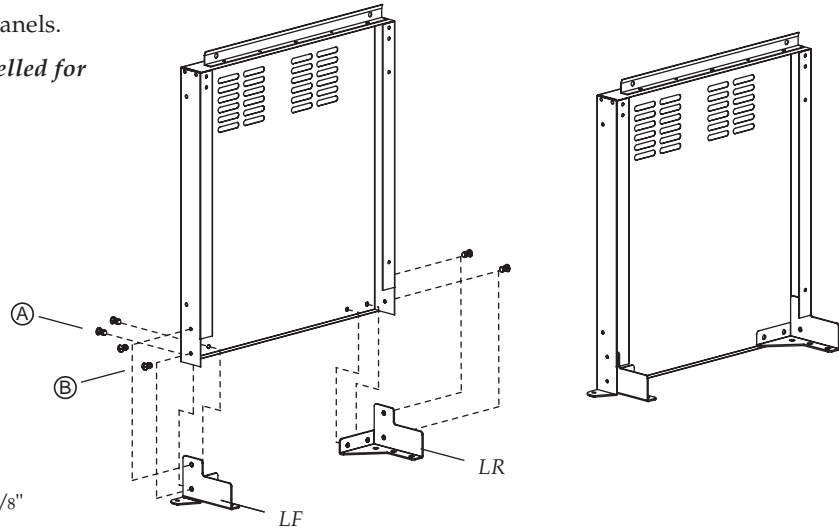

- ② Attach side panels to bottom shelf.

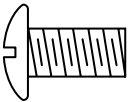

Phillips-head screw $1/4" \times 1/2"$
Qty: 8

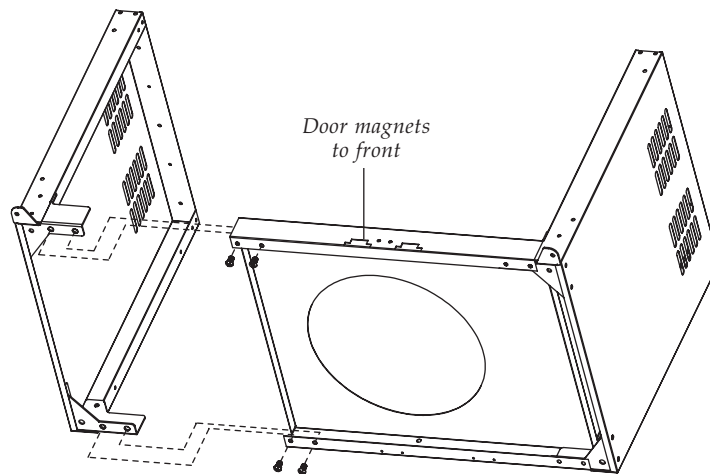

- ③ Screw castor wheels into castor seat.
Attach door guide.

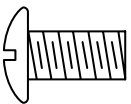

Phillips-head screw $3/16" \times 3/8"$
Qty: 2

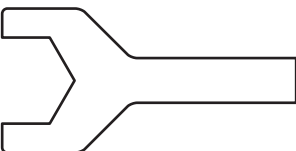

Castor wheel spanner Qty: 1

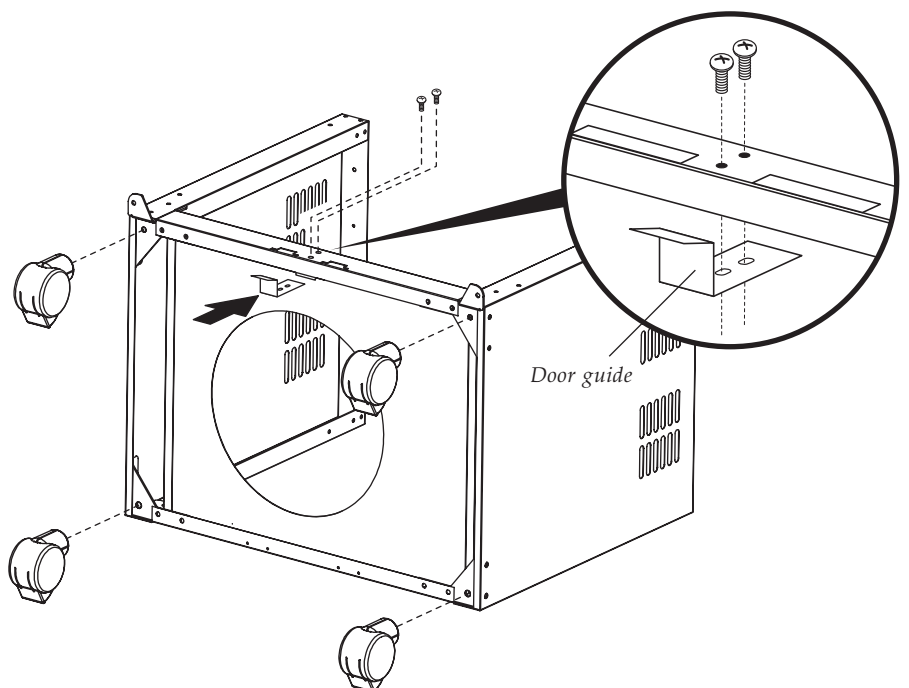

- ④ Attach the trolley bracket front and rear panel.

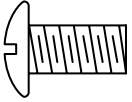

Phillips-head screw $\frac{3}{16}'' \times \frac{3}{8}''$
Qty: 8



Flange nut $\frac{3}{16}''$
Qty: 8

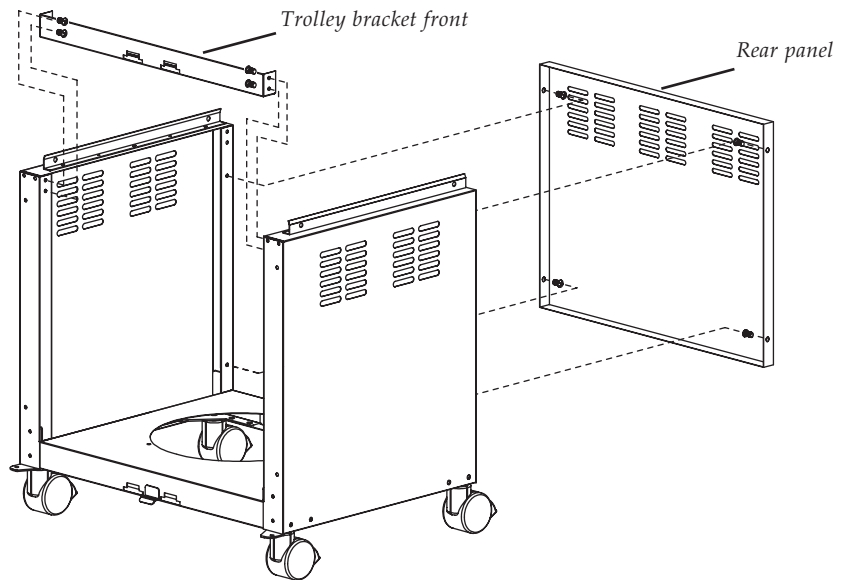

- ⑤ Attach body support brackets and gas cylinder housing, facing wing bolt to rear.

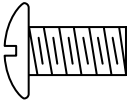

Phillips-head screw
 $\frac{3}{16}'' \times \frac{3}{8}''$ Qty: 3

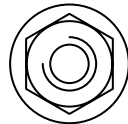

Flange nut $\frac{3}{16}''$
Qty: 3

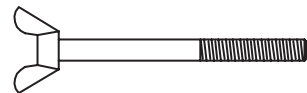

Wing bolt
Qty: 1

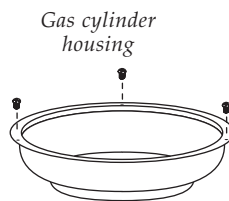

Gas cylinder housing

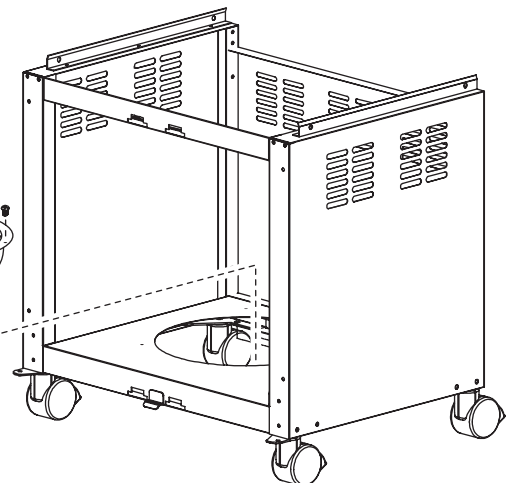

- ⑥ Attach top right and left door hinges. Insert the bottom door hinge pin into the lower door hinge bracket holes. Depress the spring loaded top door hinge pin and line up with the top hinge bracket holes, and release the pin.



Countersunk flat-head screw $\frac{3}{16}'' \times \frac{3}{8}''$
Qty: 4

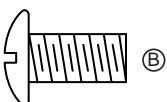

Phillips-head screw $\frac{3}{16}'' \times \frac{1}{4}''$
Qty: 4

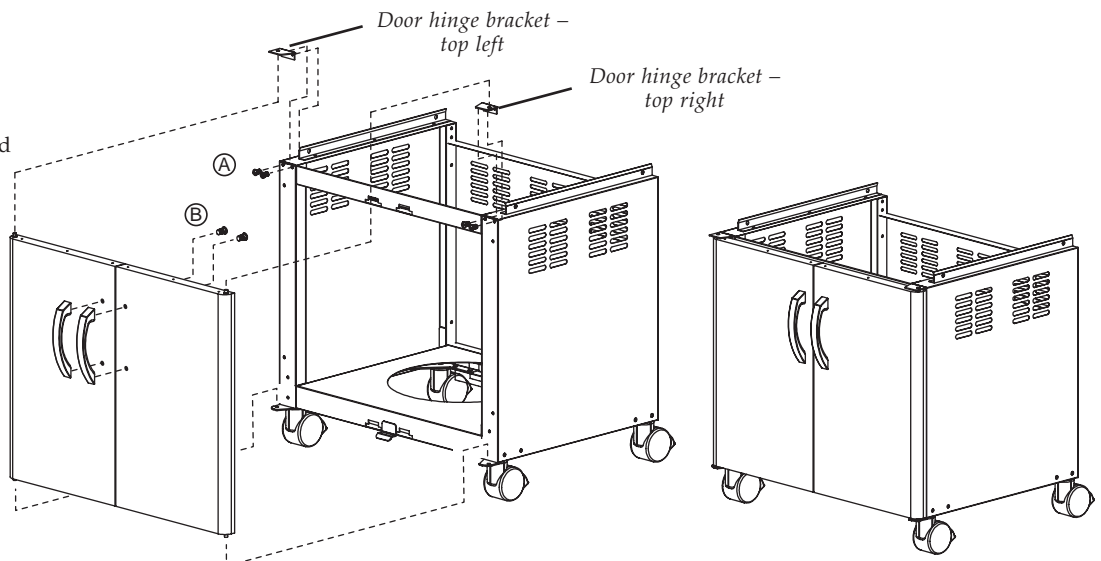

⑦ Attach barbecue body to trolley.

NOTE: Cut cable tie from underneath the barbecue head to release the gas regulator before assembling onto trolley.

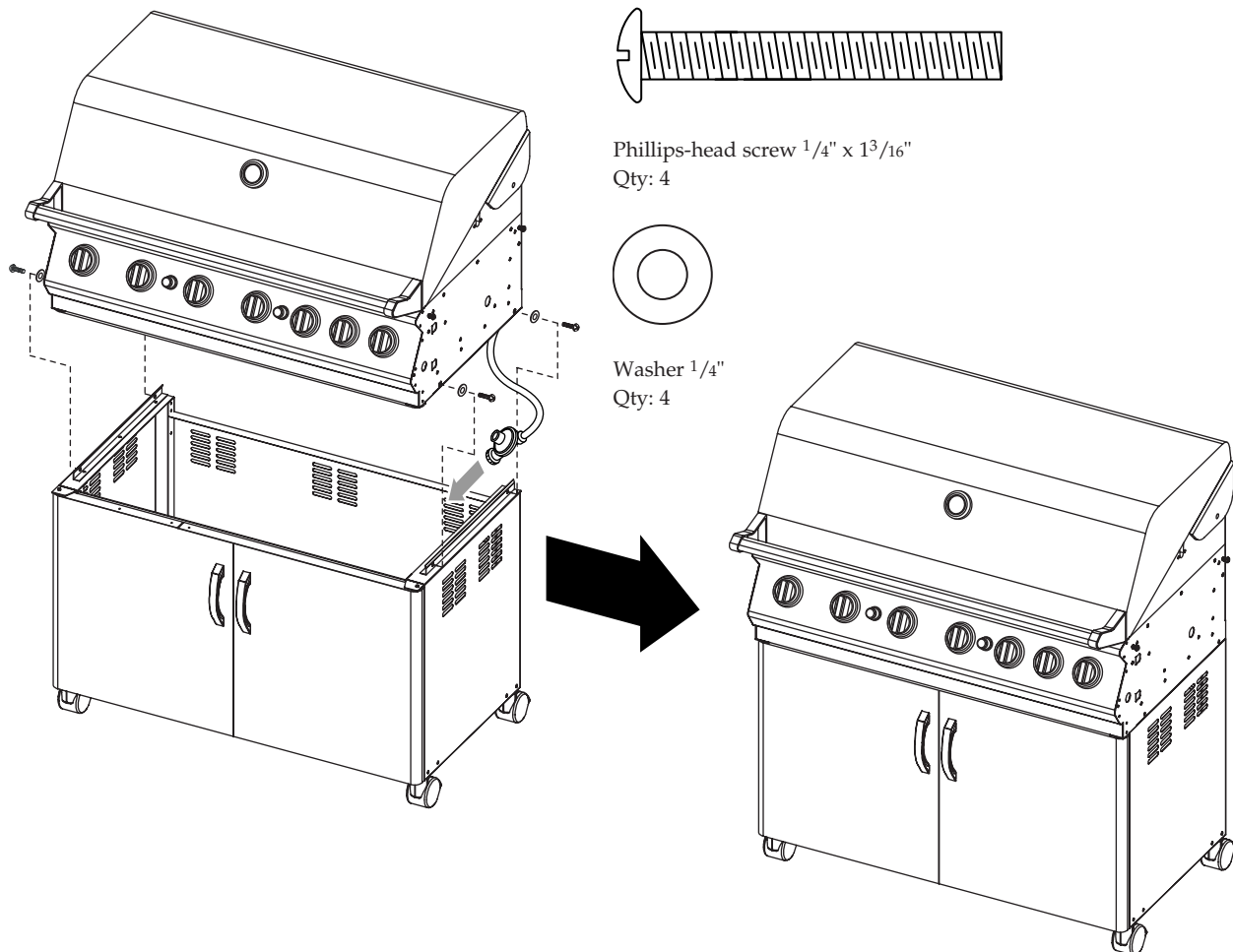

⑧ Regulator assembly

Place the LPG regulator inside the trolley through the opening above trolley rear panel. Press the hose of the LPG regulator into the hose holder above trolley rear panel. secure firmly using two (2) $\frac{3}{16}$ " x $\frac{3}{8}$ " Phillips-head screws and two (2) $\frac{3}{16}$ " x flange nuts.



Phillips-head screw
 $\frac{3}{16}$ " x $\frac{3}{8}$ "
Qty: 2



Flange nut
 $\frac{3}{16}$ "
Qty: 2

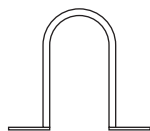

Hose holder
Qty: 1

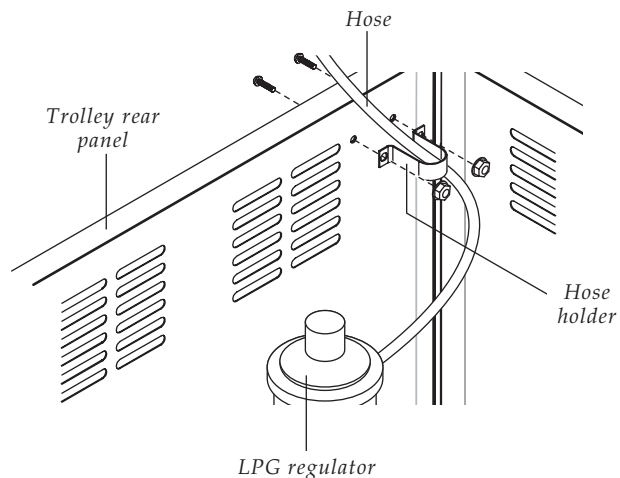

⑨ Install side shelf brackets.

From the rear of the barbecue, and below the gas hoses, slide the grease tray side tabs over the side rails underneath the barbecue body.

Install the grease receptacle under the grease tray from the front of the barbecue.

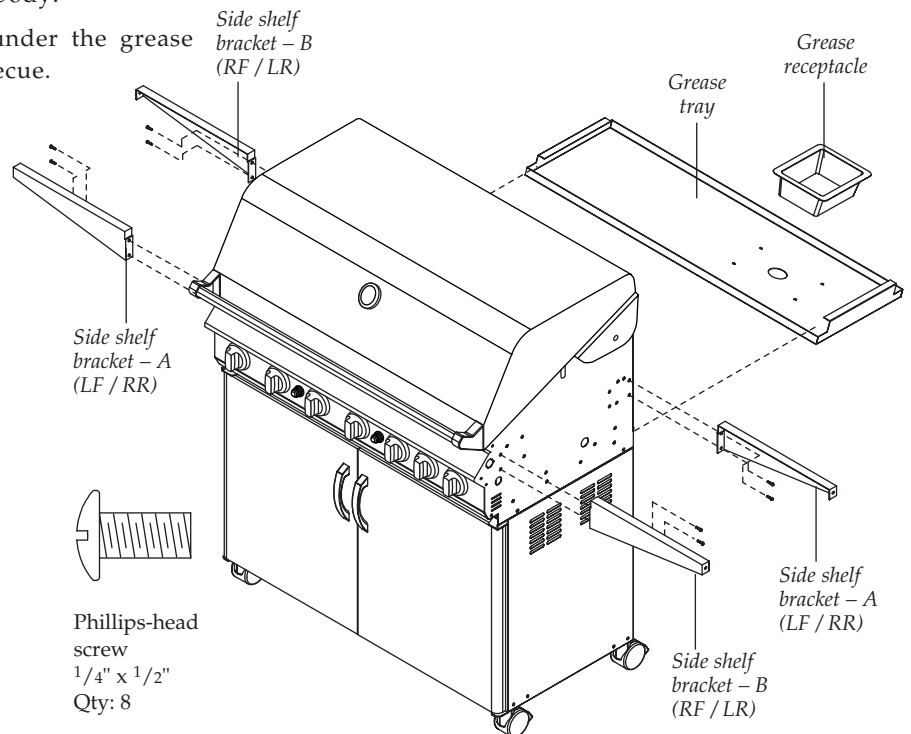

- **DO NOT LINE THE GREASE DRAINING TRAY WITH FOIL OR ABSORBENT MATERIALS**
- **THE GREASE RECEPTACLE MAY BE LINED WITH FOIL FOR EASY CLEANING**
- **GREASE / FAT FIRES ARE NOT COVERED BY WARRANTY.**

10 Install left side shelf and side burner frame

Place the side shelf over the left side shelf brackets and side burner frame over the right side shelf brackets using four (4) $\frac{1}{4}$ " x $\frac{1}{2}$ " Phillips-head screws and four (4) $\frac{1}{4}$ " flange nuts.

Tighten the left side shelf and side shelf brackets using four (4) $\frac{1}{4}$ " x $\frac{1}{2}$ " Phillips-head screws and four (4) $\frac{1}{4}$ " flange nuts. Repeat for side burner frame.

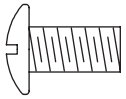

Phillips-head screw
 $\frac{1}{4}$ " x $\frac{1}{2}$ "
Qty: 8



Flange nut $\frac{1}{4}$ "
Qty: 8

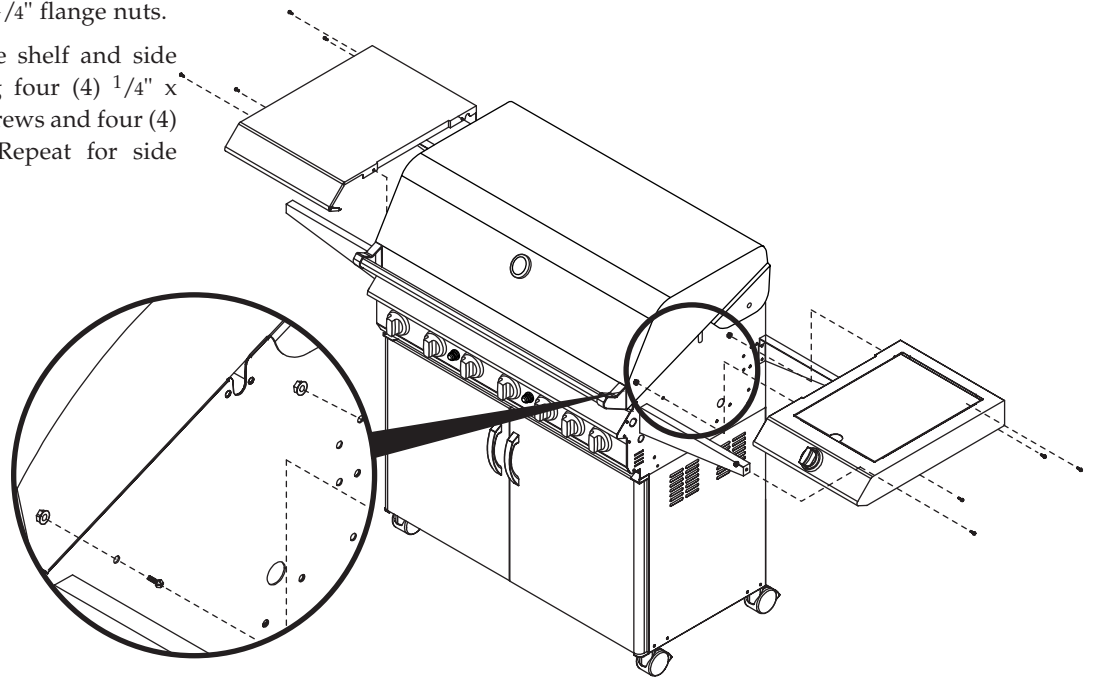

11 Install connection hose

Install connection tube to gas fitting and secure firmly the brass nut of connection tube.

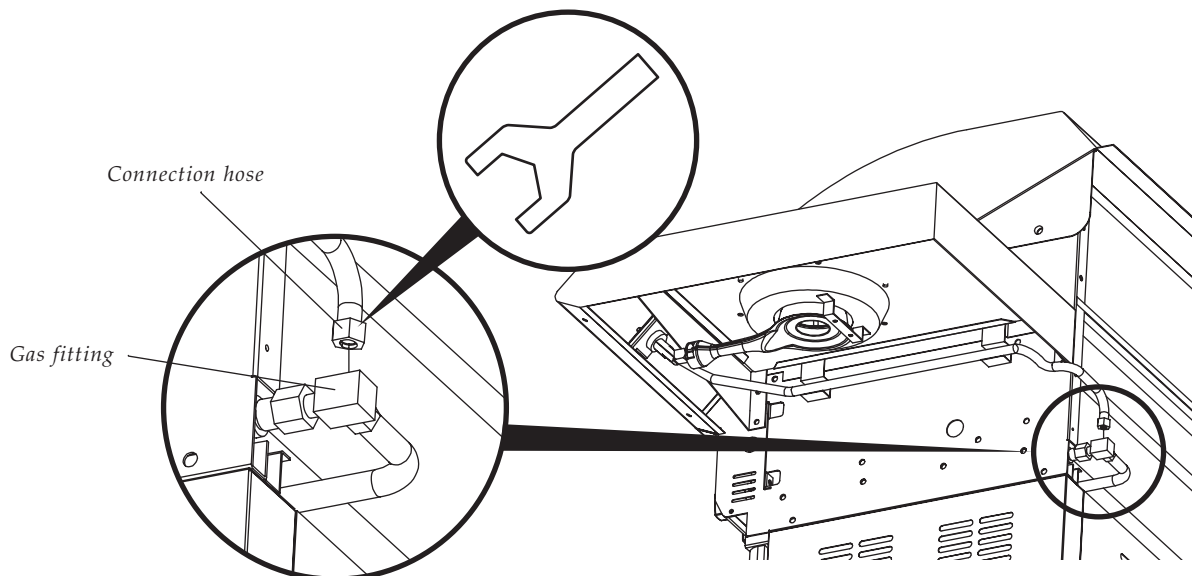

ENSURING BURNER CONTROLS ARE OFF

IMPORTANT: Before connecting and disconnecting barbecue to gas source, ensure burner controls are in 'OFF' position.

NOTE: The 'OFF' position on the control panel is identified by either a small black dot / a short vertical black line / or the word 'OFF'.

When the marking, or the word 'OFF' printed on the control knob, aligns with the printed marking on the control panel, then the burner is in the fully off position.

CAUTION: When the appliance is not in use, the gas must be turned off at the gas cylinder.

Familiarise yourself with the general information and safety guidelines located at the front of this booklet. Check to see that gas cylinder is filled and that end of each burner tube is properly located over each valve orifice. Set burner controls to 'OFF' position.

CONNECTING TO, AND DISCONNECTING FROM GAS SOURCE



TEST FOR LEAKS WITH A SOAP SOLUTION, NEVER WITH AN OPEN FLAME (Refer pages 3 and 4) .

CONNECTING TO GAS SOURCE

- Place the gas cylinder into the gas cylinder housing 'A' and face the gas cylinder valve to the right rear corner. Secure with the wing bolt.

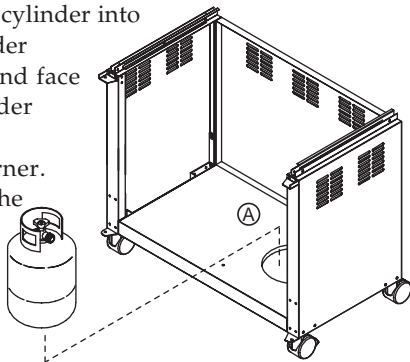

CAUTION: When the appliance is not in use, the gas must be turned off at the gas cylinder.

- Attach cylinder connection device of regulator and hose assembly to cylinder valve outlet.
Tighten firmly.

- Open the gas cylinder valve fully to allow gas to flow.
- Leak test all accessible connections thoroughly using a soapy water solution prior to lighting the barbecue.

Refer to Safety information, pages 3.

- If a leak is found, turn gas cylinder valve off and do not use barbecue until repairs or replacement can be made.

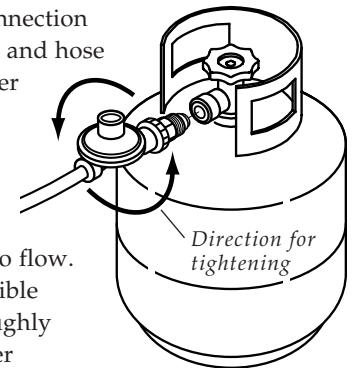

DISCONNECTING FROM GAS SOURCE

- Turn the burner control 'OFF'.
- Turn the gas cylinder valve off fully.
- Detach the regulator assembly from gas cylinder valve.



- **DISCONNECT AND REMOVE GAS CYLINDER WHEN MANOEUVRING THE BARBECUE OVER UNEVEN SURFACES OR CARRYING UP AND DOWN STAIRS**
- **IF THIS INFORMATION IS NOT FOLLOWED EXACTLY, A FIRE CAUSING DEATH OR SERIOUS INJURY MAY OCCUR!**
- **DO NOT STORE A SPARE GAS CYLINDER UNDER OR NEAR THIS APPLIANCE**
- **THIS BARBECUE IS ONLY TO BE USED OUTDOORS.**

NATURAL GAS INSTALLATION

This barbecue is also certified for use on natural gas. Contact your place of purchase for advice in relation to using your barbecue on natural gas. Refer to back cover for contact details.

Barbecues for use on natural gas must be installed by an authorised person.

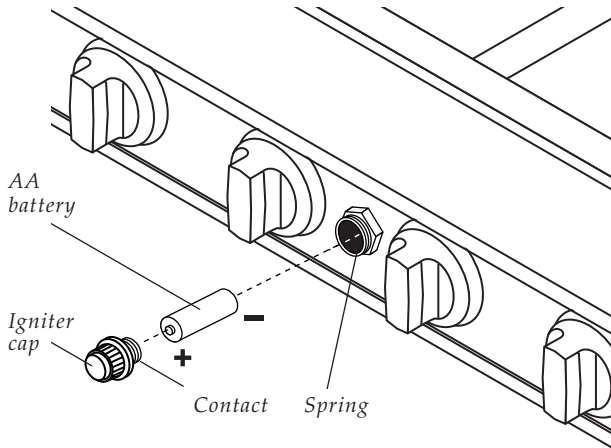
IGNITION BATTERY**BACK BURNER SPARK ELECTRODE TEST AND ADJUSTMENT – 5012 model**

Product shipping can reposition the rotisserie burner spark electrode. If your barbecue and side burner are completely assembled and this rotisserie burner electrode does not continuously spark, then conduct this adjustment.

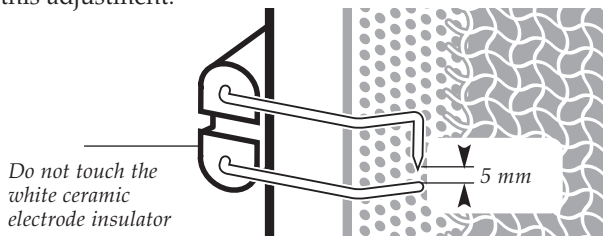

1. Turn the gas supply off at the gas cylinder.
2. Be sure the AA battery is installed and ensure the connections are secure.
3. Push the ignition button and watch for a small blue spark at the rotisserie burner electrode tip. If there is no spark you must adjust the gap between the electrode tip and the stainless steel rotisserie burner screen. The gap should be adjusted to approximately 5 mm or closer.
4. Adjust the gap using needle nose pliers. **DO NOT** adjust the gap by hand or touch the white ceramic electrode insulator. Using one set of needle nose pliers, securely hold the electrode as shown above. With another set of pliers, gently bend the tip end of electrode to within 5 mm of the stainless steel screen. Be careful not to puncture the screen or break electrode tip.
5. Try spark electrode test again. Re-adjust if necessary.

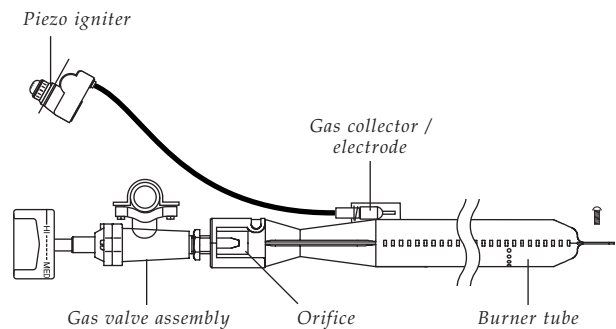
BURNER OPERATION AND IGNITION SYSTEM CHECK

1. With burner controls in 'OFF' position, open the gas cylinder valve or connect to gas supply.
2. Upon first assembly the gas lines and burners will be full of air. In order for the burners to light properly the lines must fill with gas. It may require several attempts at lighting the burners before you are successful.
3. Push the igniter button and check for sparking at the stainless steel gas collector, located adjacent to each burner.
4. If a spark is not evident at the gas collector, check that the ignition lead is firmly attached to the spark plug.
5. With sparking established at collector box, turn the burner control to 'HI' to establish a flame on the burner.
6. Push and turn the required burner control as required in an anti-clockwise direction to the 'HI' position. Cross lighting channels inside the barbecue body enables the flame to transfer across to the centre and opposite side burners to ignite them.
7. If any burners fail to light after several attempts, turn off gas supply at source.

Wait until burners cool and inspect for obstructions to gas flow. See also *Safety instructions* (pages 3, 4), *Lighting and Operating instructions* (pages 14, 15).

WITH THE ASSISTANCE OF ANOTHER PERSON, PERFORM THIS ELECTRODE CHECK BEFORE PROCEEDING.

This test will ensure that the spark electrode tips are properly positioned so your barbecue lights easily and properly.

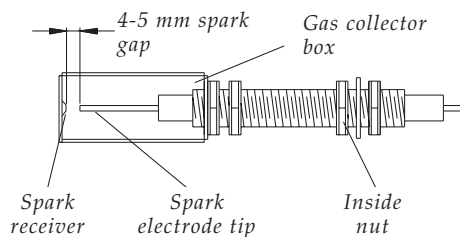

Ensure the gas source is turned off – or is disconnected and all burner control knobs are set to 'OFF' – and open the lids / side shelves.

Have your assistant stand behind to the right of the barbecue and look toward the front of the barbecue. Never put your face inside the barbecue.

Press the igniter cap. You should hear a 'clicking' sound. Your assistant should see a blue spark within each gas collector box. If a spark is present the electrode tips are properly positioned.

If no spark is seen, the spark gap needs to be adjusted as follows:

- Using an adjustable spanner, loosen the inside nut until the gas collector box can be turned upward. If the gap between the spark electrode tip and receiver is more than 4 - 5 mm use long nose pliers to gently squeeze the gas collector box to narrow gap. Return the gas collector box to its original position, secure the inside nut and try the electrode check again.

If no 'clicking' sound is heard:

- AA battery may be installed backwards.
- Electronic wires may be loose. Remove the AA battery and inspect the igniter junction box found behind the control panel and reconnect any loose wires.



- CHECK PERFORMANCE OF BURNERS PRIOR TO INSTALLING BARBECUE PLATE COMPONENTRY. Refer pages 14 and 15 for lighting instructions**
- DO NOT SMOKE WHEN ATTEMPTING TO IGNITE BARBECUE**
- NEVER USE VOLCANIC ROCK, HEAT BEADS OR OTHER MATERIAL**
- ALWAYS USE PROTECTIVE GLOVES WHEN HANDLING HOT COMPONENTS.**

SIDE BURNER ELECTRODE CHECK

- Open side burner lid. Remove plastic shipping band from burner and pot support.
- Push and turn side burner control knob to 'HI'. Look for spark between tip of electrode and burner.
- If you don't see a spark from side burner electrode, adjust gap between electrode and burner surface to 4 - 5 mm.

FLAME TAMERS

The flame tamer plate is designed to reduce flaring. The plates fit onto the ledge at the front and rear of the barbecue body. Position with the slots to the front as shown below.

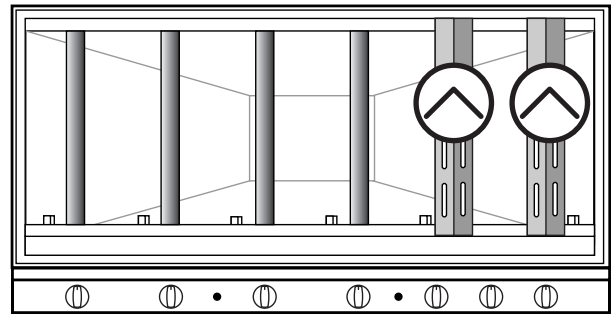

COOKING PLATES

The grill plates must be positioned over the flame tamers. Position hot plate and grill plates as indicated below.



DO NOT COVER ENTIRE COOKING SURFACE WITH SOLID PLATES, AS THIS WILL RESULT IN POOR COOKING PERFORMANCE, OR THE BURNERS MAY GO OUT, CREATING A HAZARDOUS SITUATION.

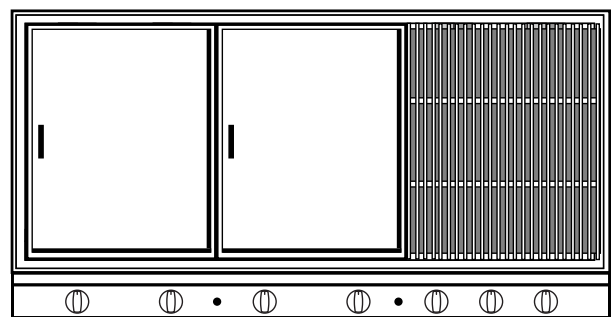

TEMPERATURE GAUGE

The temperature gauge is used as a guide to cooking temperatures when cooking with the hood closed. When an opening is provided in the hood, this allows for the installation of the temperature gauge. *Install as shown in the diagram, if not factory fitted.*

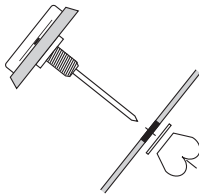

NOW YOUR BARBECUE IS READY TO USE

Before first use and at the beginning of each barbecue season:

1. Please read *Safety, Lighting and Operating instructions* carefully.
2. Check gas valve orifices, burner tubes and burner ports for any obstructions. *eg. spiders, webs, insects.*
3. Check and ensure the gas cylinder is full.
4. **Ensure all connections are securely tightened. Check for gas leaks. See pages 3.**

MAIN BURNER IGNITION

1. Open barbecue hood before attempting to light burners.
2. Set burner control knobs to 'OFF' and open the gas cylinder valve.

NOTE: *Upon first assembly the gas lines and burners will be full of air. In order for the burners to light properly the lines must fill with gas. It may require several attempts at lighting the burners before you are successful.*



3. Push and turn the required burner control knob to 'HI'.
4. Immediately press the continuous spark igniter for up to 15 seconds to light the burner.
5. If the burner does not light, turn the burner control knob to 'OFF', wait 5 minutes for gas to clear, then retry.
6. Once the burner is ignited, the adjacent burner can be lit by simply turning its control knob to 'HI'.
7. Adjust burner control knobs to your desired cooking temperature.
8. If ignition cannot be achieved, perform ignition check procedure. *Refer to pages 12 and 13.*

BACK BURNER IGNITION

NOTE: *The location of the back burner makes it more susceptible to wind conditions that will decrease the performance of your rotisserie cooking. For this reason you should not operate the back burner during windy weather conditions.*

1. Open barbecue hood before attempting to light back burner.

2. Set burner control knobs to 'OFF' and open the gas cylinder valve.

3. Push and turn back burner control knob to 'HI'.

4. Then immediately press the continuous spark igniter for 3 - 4 seconds to light the burner.

5. If the burner does not light, turn the control knob to 'OFF', wait 5 minutes, then retry.

6. Once the burner is ignited, the back burner will reach cooking temperature quickly. The orange / red glow will even out in about 5 minutes.

7. For best results, always rotisserie cook with the hood down.

NOTE: *If extra heat is required, then any of the main burners may be used on the 'LOW' setting only. Do not exceed 250° with hood closed.*

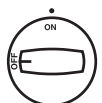
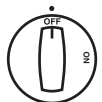
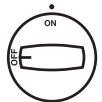
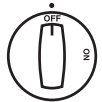

SIDE BURNER IGNITION – All models

1. Open side burner lid before attempting to light side burner.

2. Set burner control knobs to 'OFF' and open the gas cylinder valve.

3. Push and turn the control knob anti-clockwise until a "click" is heard.

4. Immediately the piezo igniter will be triggered to light the burner.

5. If the burner does not light, turn the control knob to 'OFF', wait 5 minutes, then retry.

6. Adjust burner control knob to desired flame level.

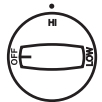
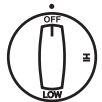

CAUTION: *IF BURNERS GO OUT DURING OPERATION, CLOSE GAS SUPPLY AT SOURCE, AND TURN ALL BURNER CONTROLS OFF.*

OPEN HOOD AND WAIT 5 MINUTES BEFORE RE-ATTEMPTING TO LIGHT (ENSURE ACCUMULATED GAS FUMES HAVE CLEARED).

CAUTION: *SHOULD A GREASE FIRE OCCUR, ATTEMPT TO CLOSE GAS SUPPLY AT SOURCE, TURN OFF ALL BURNERS AND REMOVE FOOD IF POSSIBLE.*

KEEP THE VENTILATION OPENINGS OF THE CYLINDER ENCLOSURE FREE AND CLEAR FROM DEBRIS.

THE HOOD MUST BE IN THE OPEN POSITION FOR LIGHTING.

DO NOT SMOKE AT ALL TIMES WHEN ATTEMPTING TO IGNITE BARBECUE.

CAUTION: *DO NOT MOVE TROLLEY WHILE BARBECUE IS IN OPERATION.*

THE SIDE BURNER IS DESIGNED FOR USE WITH A WOK UP TO 360 mm DIAMETER, AND COOKING PAN OF UP TO 200 mm DIAMETER.

USE OF VERY LARGE POTS MAY RESULT IN DISCOLOURATION OF THE SURFACE FINISH, OR CAUSE POOR COMBUSTION.

OPERATING PROCEDURE

BURN-OFF

Before cooking on your barbecue for the first time, burn-off any residual oils or foreign matter from the cooking plates. **ENSURE THE LID IS REMOVED OR THE HOOD OPEN**, and operate at 'HI' setting for approximately 15 minutes. Allow to cool then wash grill/plate/pan thoroughly with soap suds and scrubbing brush. Rinse thoroughly and wipe clean with a cloth. Your grill/plate/pan is ready to use.

PREHEATING

It is necessary to preheat the barbecue before cooking. Operate the burner(s) under the cooking surface to be used at 'HI' for approximately 10 minutes before cooking. Hooded barbecues should be pre-heated with the hood down.



EXTENDED PERIODS OF PRE-HEATING WITH THE HOOD DOWN MAY DAMAGE THIS APPLIANCE.

COOKING TEMPERATURES

'HI' setting – Use this setting only for warm up, for searing steaks and chops, and for burning food residue from the grill plates after the cooking is over. Rarely, if ever, do you use the 'HI' setting for extended cooking.

'MEDIUM' setting (*mid-way between 'HI' and 'LOW'*). Use this setting for most grilling, and for cooking hamburgers and vegetables.

'LOW' setting – Use this setting when cooking very lean cuts such as fish.

Actual cooking surface temperatures vary with outside temperature and the wind conditions.

MANUAL LIGHTING

If for some reason, igniters fail to produce a spark at the electrode, barbecue can be lit carefully with a match.

Insert lit match or long-necked butane lighter through lighting hole located on right side of barbecue body, after turning the right burner control to the 'HI' position.

Sequentially light the remaining burners from right to left.

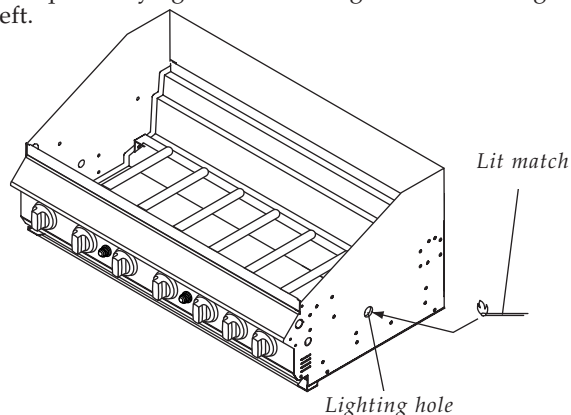

- **THE SIDE BURNER IS DESIGNED FOR USE WITH A WOK UP TO 360 mm DIAMETER AND COOKING POTS UP TO 200 mm DIAMETER**
- **USE OF VERY LARGE POTS MAY RESULT IN DISCOLOURATION OF THE SURFACE FINISH, OR CAUSE POOR COMBUSTION.**

FLARE-UPS

The fats and juices that drip from the meat may cause flare-ups. Since flare-ups impart the distinctive taste and colour for food cooked over an open flame, they should be expected and encouraged within reason. Nevertheless, uncontrolled flaring can result in a ruined meal.

COOKING WITH THE HOOD DOWN

Cooking with the hood in the closed position helps to cook food more quickly than in conventional barbecues with a simple lid. The hood (*when closed*) helps to retain the heat more evenly and conserves energy.

IMPORTANT: *Never use any burner or combination of burners on 'HI' for extended periods when cooking with the hood down.*

High direct heat when the hood is down may result in burnt food, or damage to painted surfaces.

When roasting in your barbecue, food should be positioned over the centre burners either on a roasting rack with the cooking pan underneath, or directly in the cooking pan, or placed in a disposable aluminium foil dish on top of a flame tamer. Remove other grill plate and hot plate not being used, and ignite burners 1, 2, 5 & 6.

It is recommended not to exceed 250°C when cooking with the hood down. The heat from the selected burners circulates gently throughout the barbecue, cooking the meat or poultry without any direct flame touching it. This method greatly reduces flare-ups when cooking extra fatty cuts, because there is no direct flame to ignite the fats and juices that drip during cooking.

PRE HEATING

With the hood open, ignite the outer left and right burners. Once ignition is established, close the hood. Leave the burners on 'HI' for 10 minutes or until the temperature reaches a suitable level for cooking. Modulate the required temperature by turning the left and right burners progressively to 'LOW'.

ROTISSERIE

Rotisserie is available as an optional extra from your place of purchase.

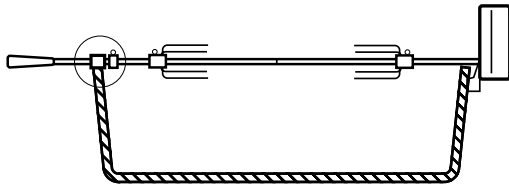

SAFETY POINTS

- Do not operate damaged rotisserie.
- Do not use rotisserie in poor weather conditions.
- Avoid contact with hot surfaces.
- Always load rotisserie to barbecue before switching motor on.
- Always turn rotisserie 'OFF' before removing from barbecue.
- Do not leave rotisserie on barbecue when not in use.

LOADING THE SPIT RODS

- Assemble rotisserie rod as shown.
- Centre food on the spit rod.
- Use butcher string to secure loose portions.

ROTISSERIE COOKING

- Rotisserie cooking produces foods that are moist, flavoursome and appealing. The rotating food self bastes. Although the rotisserie is best for larger pieces of meat or poultry, most cuts can be used if prepared properly.
- The balancing of the food requires the most attention in rotisserie cooking. The rotisserie must turn evenly otherwise the stopping and starting action will cause the food to cook unevenly and possibly burn the heavier side. Refer to the diagram below.

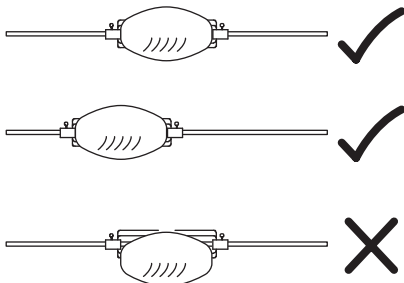

- The easiest foods to balance are those of uniform shape and texture. To test if the food is balanced correctly when secured, place the ends of the rotisserie skewer loosely in the palm of your hands. Give the spit a quarter turn and if there is no tendency to roll and it is stable give it a another quarter turn. It should rest without turning in each of these positions.

It can then be attached to the barbecue.

- When using poultry, truss the bird tightly so that wings and drumsticks are close to the body of the bird. The cavity of the bird can be stuffed prior to this, if you wish. Pull the neck skin down and using a small skewer fix to the back of the bird. Push the rotisserie skewer through lengthwise, catching the bird in the fork of the wishbone. Centre the meat and tighten the holding forks. Test the balance as described above.
- A rolled piece of meat only requires the rotisserie skewer to be inserted through the centre of the length of meat, then secured and balanced using the forks.
- For meats which are un-boned, it is best to secure the rotisserie skewer diagonally through the meaty sections. If protruding bones or wings brown too quickly, cover with pieces of foil.

SETTING UP THE BARBECUE

- Remove all the cooking plates from the barbecue and position the flame tamer centrally. Place either an oven proof cooking pan or disposable aluminium foil dish on top of the flame tamer under the food being cooked so that it catch any drips from the food above. The drippings can be used to make gravies and other sauces to accompany the cooked meat.
- Once the barbecue has been set up, pre-heat the barbecue according to the manufacturer instructions. Close the hood when you start to cook.
- For foods with little fat you may wish to cook them directly over lit burners to give a charred effect. This should only be done towards the end of the cooking for no longer than the time required to give the desire visual effect. Do not attempt this with fatty foods as this will cause flare-ups and excessive smoke.

COOKING TIMES

- This will vary according to the type and weight of food you are cooking. However as a guide the cooking times on a rotisserie are similar to conventional oven cooking.



- SHOULD A FLASHBACK FIRE OCCUR IN OR AROUND THE BURNER TUBES, FOLLOW THE INSTRUCTIONS BELOW. FAILURE TO COMPLY WITH THESE INSTRUCTIONS COULD RESULT IN A FIRE OR EXPLOSION THAT COULD CAUSE SERIOUS BODILY INJURY, DEATH, OR PROPERTY DAMAGE
- SHUT OFF GAS SUPPLY TO THE GAS BARBECUE
- TURN THE CONTROL KNOBS TO OFF POSITION
- OPEN THE BARBECUE LID. PUT OUT ANY FLAME WITH A FIRE EXTINGUISHER
- ONCE THE BARBECUE HAS COOLED DOWN, CLEAN THE BURNER TUBES AND BURNERS ACCORDING TO THE CLEANING INSTRUCTIONS IN THIS OPERATOR'S MANUAL.

CAUTION: If burners go out during operation, close gas supply at source, and turn all gas valves off. Open hood and wait 5 minutes before re-attempting to light (this allows accumulated gas fumes to clear).

CAUTION: Should grease fire occur, close gas supply at source, turn off all burners and remove food until fire is out.

KEEP THE VENTILATION OPENINGS OF THE CYLINDER ENCLOSURE FREE AND CLEAR FROM DEBRIS.

IF THE BARBECUE FAILS TO LIGHT

1. Turn gas off at source and turn burner control knobs to 'OFF'. Wait at least five (5) minutes for gas to clear, then retry.
2. If your barbecue still fails to light, check gas supply and connections.
3. Repeat lighting procedure. If your barbecue still fails to operate, turn the gas off at source, turn the control knobs to 'OFF', then check the following:
 - **Misalignment of burner tubes over orifices**
Correction: Reposition burner tubes over orifices.
 - **Obstruction in gas line**
Correction: Remove fuel line from barbecue. Do not smoke! Open gas supply for one second to clear any obstruction from fuel line. Close off gas supply at source and reconnect fuel line to barbecue.
 - **Plugged orifice**
Correction: Remove burners from barbecue by pulling cotter pin (beneath burner) using long nose pliers. Carefully lift each burner up and away from gas valve orifice. Remove the orifice from gas valve and gently clear any obstruction with a fine wire. Then reinstall all orifices, burners, cotter pins and cooking components.

If an obstruction is suspected in gas valves or manifold, contact your place of purchase or manufacture.
 - **Obstruction in burner tubes**
Correction: Follow the burner tube cleaning procedure on page 20 of this operator's manual.
 - **Misalignment of igniter on burner**
Correction: Check for proper position of the electrode tip as shown on pages 12 and 13. The gap between the spark electrode tip and spark receiver should be approximately 4 - 5 mm. Adjust if necessary. With the gas supply closed and all control knobs set to 'OFF' press the electronic igniter cap and check for the presence of a spark at the electrode.
 - **Disconnected electronic wires**
Correction: Inspect the igniter junction box found behind the control panel. Connect loose electronic wires to junction box and try to light the barbecue.
 - **Weak AA battery**
Correction: Unscrew the igniter cap and replace the battery.



DO NOT USE OVEN CLEANER TO CLEAN THE BARBECUE.



FAILURE TO READ AND FOLLOW THE USE AND CARE INSTRUCTIONS COULD RESULT IN A FIRE OR EXPLOSION THAT COULD CAUSE SERIOUS BODILY INJURY, DEATH OR PROPERTY DAMAGE.



IN COASTAL AREAS, FREQUENT CLEANING AND THE USE OF A COVER IS RECOMMENDED TO PROLONG THE LIFE OF THE APPLIANCE. SALTY AIR WILL ADVERSELY AFFECT EXPOSED PARTS.

CLEANING AND MAINTENANCE

Proper care and maintenance will keep your barbecue in top operating condition and prolong its life. Follow these cleaning procedures on a timely basis and your barbecue will stay clean and operate with minimum effort.

CAUTION: Be sure your barbecue is off and cool before cleaning.

CLEANING THE COOKING PLATES

Before initial use, and periodically, wash your cooking plates in a mild soap and warm water solution. You can use a wash cloth or vegetable brush to clean your cooking plates.

It is recommended the cooking plates be coated with a thin layer of cooking oil on a regular basis to prevent rusting. Slight rusting can be removed with a scrubbing brush before use.

CLEANING THE FLAME TAMERS

Periodically you should wash the flame tamer in a soap and warm water solution. Use a vegetable brush to remove stubborn burnt-on cooking residue. Dry the flame tamers thoroughly before you re-install them into the barbecue.

CLEANING THE GREASE TRAY AND RECEPTACLE

To reduce the chance of fire, the grease draining tray and grease receptacle should be visually inspected before each barbecue use. Remove any grease and wash grease tray and receptacle with a mild soap and warm water solution.

NOTE: Grease / fat fires are not covered by warranty.

CLEANING EXTERIOR SURFACES

Before initial use, and periodically thereafter, we suggest you wash your barbecue using a mild soap and warm water solution. You can use a wash cloth or sponge for this process. Do not use a stiff wire or brass brush. These will scratch stainless steel and chip painted surfaces (varies by model) during the cleaning process.

CARE FOR STAINLESS STEEL SURFACE

The stainless steel over time will be affected by 'tea staining' (*the brown discolouration of some stainless steel*).

Tea staining can be reduced by washing the surface with mild detergent and warm water. This should then be followed by rinsing with clean cold water. We recommend the surface then be wiped dry with a clean cloth.

STORAGE

We recommend that you minimise the barbecue's exposure to the elements. High moisture content in the air (*rain, mist, salt spray etc.*) can affect metal components and lead to material breakdown. If left in an area subjected to high moisture content, we strongly recommend that you observe the cleaning procedure on a regular basis and cover the appliance whilst not in use (*covers are available as an optional extra*). Material breakdown from high moisture conditions can be avoided if the appliance is well protected from the weather and regular cleaning is carried out.

ANNUAL CLEANING OF THE BARBECUE INTERIOR

Burning-off excess food after every cookout will keep it ready for instant use. However, at least every 3 months you must give the entire barbecue a thorough cleaning to minimise your risk of grease fire and keep the barbecue in top shape. *Follow these steps:*

1. Turn all burner valves to the full 'OFF' position.
2. Turn the LP gas cylinder valve to the full 'OFF' position.
3. Disconnect the regulator from the gas cylinder. Inspect the hose with regulator assembly for cracking, cuts or any other damage, and replace as necessary. *Refer to the Parts List in this operator's manual, pages 22 - 23.*
4. Remove and clean the flame tamers, cooking plates and barbecue burners.
5. Cover each gas valve orifice with aluminum foil.
6. Brush the inside and bottom of the barbecue with a fibre pad or nylon brush and wash with a mild soap and warm water solution. Rinse thoroughly and let dry.
7. Remove aluminum foil from orifices and check each orifice for obstruction.
8. Check each spark electrode, adjusting as needed. The space between the spark electrode tip and spark receiver should be approximately 4 - 5 mm.
9. Replace the burners and adjust the gas collector box. The edge of the collector box should be overlapping the burner port.
10. Reconnect the gas source and observe the burner flame for correct operation.
11. Replace flame tamers and cooking plates.



- **BEWARE OF SPIDERS. BURNER TUBES SHOULD BE INSPECTED AND CLEANED PERIODICALLY.**



- **SPIDERS AND SMALL INSECTS CAN OCCASIONALLY SPIN WEBS OR MAKE NESTS IN THE BURNER TUBES. THESE WEBS CAN LEAD TO A GAS FLOW OBSTRUCTION WHICH COULD RESULT IN A FIRE IN AND AROUND THE BURNER TUBES**
- **THIS TYPE OF FIRE IS KNOWN AS 'FLASH-BACK' AND CAN CAUSE SERIOUS DAMAGE TO YOUR BARBECUE AND CREATE AN UNSAFE OPERATING CONDITION FOR THE USER**
- **ALTHOUGH AN OBSTRUCTED BURNER TUBE IS NOT THE ONLY CAUSE OF 'FLASH-BACK' IT IS THE MOST COMMON CAUSE AND FREQUENT INSPECTION AND CLEANING OF THE BURNER TUBES IS NECESSARY.**



- **KEEP BARBECUE AREA CLEAR AND FREE FROM COMBUSTIBLE MATERIALS, GASOLINE AND OTHER FLAMMABLE VAPOURS AND LIQUIDS**
- **DO NOT OBSTRUCT THE FLOW OF AIR FOR COMBUSTION AND VENTILATION**
- **KEEP THE VENTILATION OPENINGS OF THE CYLINDER ENCLOSURE CABINET FREE AND CLEAR OF DEBRIS**
- **VISUALLY CHECK BURNER FLAMES OCCASIONALLY TO ENSURE PROPER FLAME PATTERN AS SHOWN BELOW**
- **FAILURE TO COMPLY WITH THESE INSTRUCTIONS MAY RESULT IN A HAZARDOUS SITUATION WHICH, IF NOT AVOIDED, MAY RESULT IN INJURY.**



Magnified view of burner flame through lighting hole

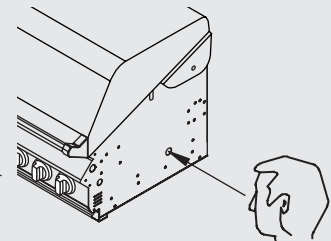

CLEANING THE BURNER TUBES AND BURNER PORTS

To reduce the chance of FLASHBACK FIRE you must clean the burner tubes as follows at least once a month in summer and fall or whenever spiders are active in your area, and if your barbecue has not been used for an extended period of time.

1. Turn all burner valves to the full 'OFF' position.
2. Turn the LP gas cylinder valve to the full 'OFF' position.
3. Detach the LP gas regulator assembly from your gas barbecue.
4. Remove the cooking plates, flame tamer plates and grease trays from your barbecue.
5. Remove the screw from the rear of each burner using a Phillips-head screwdriver.
6. Carefully lift each burner up and away from the gas valve orifice.
7. Check and clean burner/venturi tubes for insects and insect nests. A clogged tube can lead to a fire beneath the barbecue.
8. Refer to diagram 1 and perform one of these three cleaning methods:

METHOD 1: Bend a stiff wire or wire coat hanger into a small hook as shown and run the hook through the burner tube and inside the burner several times to remove debris.



METHOD 2: Use a bottle brush with a flexible handle and run the brush through the burner tube and inside the burner several times to remove any debris.

METHOD 3: Use an air hose to force air through each burner tube. The forced air should pass debris or obstructions through the burner and out the ports.

Regardless of which burner cleaning procedure you use, we recommend you also complete the following steps to help prolong burner life.

1. Use a fibre pad or nylon brush to clean the entire outer surface of each burner until free of food residue and dirt.
2. Clean any clogged ports with a stiff wire, such as an open paper clip.
3. Inspect each burner for damage (*cracks or holes*) and if such damage is found, order and install a new burner. After installation, check to ensure that the gas valve orifices are correctly placed inside the ends of the burner tubes. Also check the position of your spark electrode.



FOR SAFE OPERATION ENSURE THE GAS VALVE ASSEMBLY ORIFICE IS INSIDE THE BURNER TUBE BEFORE USING YOUR BARBECUE. See diagram. IF THE ORIFICE IS NOT INSIDE THE BURNER TUBE, LIGHTING THE BURNER MAY CAUSE EXPLOSION AND / OR FIRE RESULTING IN SERIOUS BODILY INJURY AND / OR PROPERTY DAMAGE.

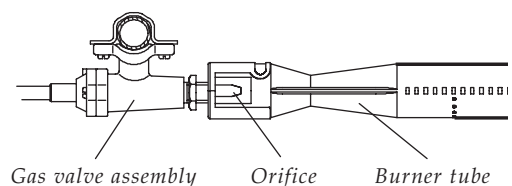
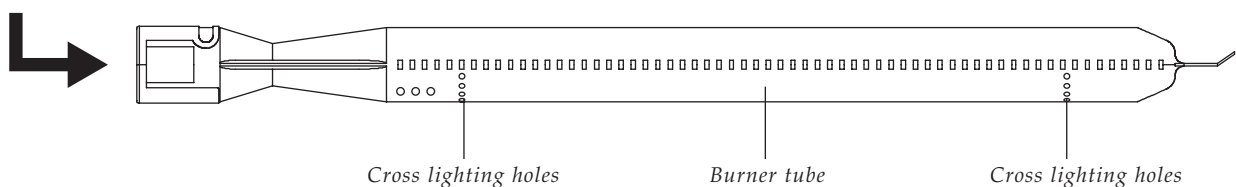

Diagram 1.

To clean burner tube, insert hook as indicated by the arrow.



BURNER IS TO BE INSTALLED WITH THE CROSS IGNITION HOLES UNDERNEATH.

THIS PAGE HAS BEEN LEFT INTENTIONALLY BLANK

This diagram is provided to assist you identify parts if replacement is necessary. Contact your place of purchase or the manufacturer to enquire about parts, availability and or service.

Items included in your barbecue specification may differ from the parts list, depending on region or specific dealer specification.

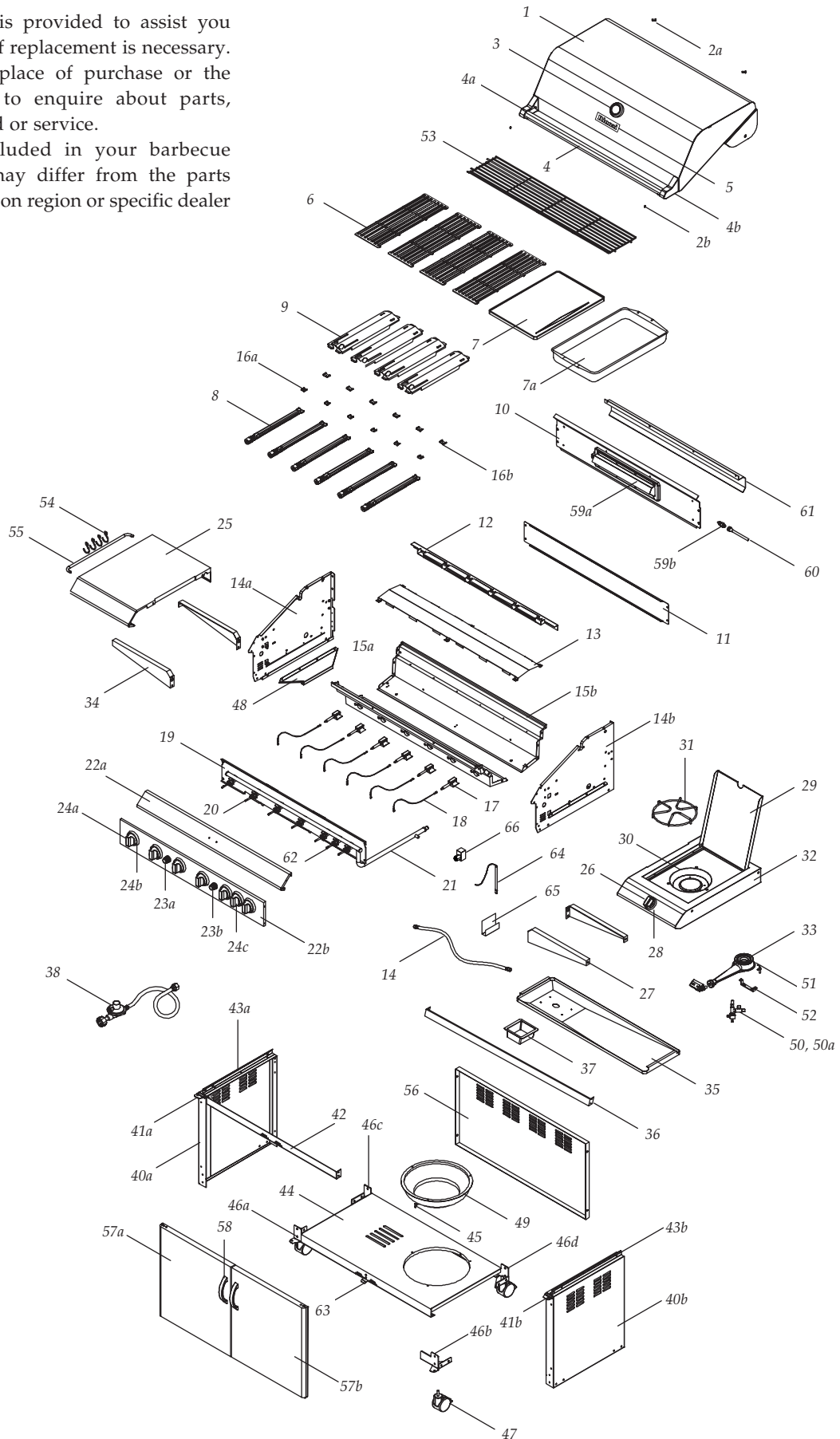

Ref	Description	Part No.	Qty
1	Hood	P00145044C	1
2a	Hood hinge	P05501018A	2
2b	Protective pad	P05518002I	2
3	Temperature gauge	P00601011B	1
4	Hood handle	P00206004M	1
4a	Hood handle bracket – left	P00301086A	1
4b	Hood handle bracket – right	P00302086A	1
5	Name plate	P00415006C	1
6	Grill plate	P01615028H	4
7	Hot plate	P01702008K	1
7a	Cooking pan	P05805011F	1
8	Burner – main	P02008015A	6
9	Flame tamer	P01708033E	4
10	Bowl wind shield	P06905028A	1
11	Rear wind shield	P00751011B	1
12	Burner bracket	P0220606ED	1
13	Bowl heat shield	P06903034A	1
14a	Bowl panel – left	P0072078NA	1
14b	Bowl panel – right	P0072179NA	1
15a	Bowl panel – front	P00738634A	1
15b	Bowl panel – rear	P00725674A	1
16a	Flame tamer bracket – front	P03328050A	6
16b	Flame tamer bracket – rear	P03328051A	6
17	Gas collector with electrode	P02609002B	6
18	Wire set	P02615081A	1
19	Heat shield	P03010121B	1
20	Gas valve – main without jet	P03222132A	6
20a	Gas jet – main burner	P06517005A	6
21	Manifold	P05013012A	1
22a	Control panel – top	P02914021A	1
22b	Control panel – bottom with screen print	P0291401BA	1
23a	Igniter – 6 point	P02502075C	1
23b	Igniter – 2 point	P02502192C	1
24a	Control knob – main burner	P03419413L	6
24b	Control knob seat – main / back burner	P03415014S	7
24c	Control knob – back burner	P03419403L	1
25	Side shelf – left	P01106042S	1
26	Control knob – side burner	P03401043S	1
27	Side shelf bracket – RF / LR	P01206005B	2
28	Control knob seat – side burner	P03408053S	1
29	Side shelf lid	P0011538P4	1
30	Side shelf body	P011020364	1
31	Side shelf pot support	P00805010B	1
32	Side shelf trim plate	P01108012S	1
33	Side burner	P02002012A	1
34	Side shelf bracket – LF / RR	P01204005B	2
35	Grease draining tray	P02717115B	1
36	Trolley bracket – front	P033050194	1
37	Grease receptacle	P02701187B	1
38	Regulator	P03603008A	1
39	Connection tube	P03705084F	1
40a	Trolley panel – left	P07605005B	1
40b	Trolley panel – right	P07606005B	1
41a	Door hinge bracket – top left	P03313006D	1
41b	Door hinge bracket – top right	P03313007D	1
42	Door bracket – upper	P03301037D	1
43a	Bowl support bracket – left	P03315001D	1
43b	Bowl support bracket – right	P03315002D	1
44	Trolley bottom shelf	P01004065D	1
45	Wing bolt	S233G05261	1
46a	Castor seat – LF	P05327019G	1
46b	Castor seat – RF	P05327020G	1
46c	Castor seat – LR	P05327018G	1
46d	Castor seat – RR	P05327017G	1
47	Castor – 3"	P05112002A	4
48	Grease tray track	P05330102G	2
49	Gas cylinder frame	P04021003C	1
50	Gas valve – side without jet	P03226009C	1
50a	Gas jet – side burner	P06519081A	1
51	Ignition wire set – side	P02607002A	1
52	Side burner bracket	P03309003F	1
53	Cooking rack – fixed	P01508007H	1
54	Tool holder	P05212013F	1
55	Tool hook	P05514130L	3
56	Trolley rear panel	P07702044B	1
57a	Door – left	P04305004D	1
57b	Door – right	P04306004D	1
58	Door handle	P00201001C	2
59a	Back burner	P02007014A	1
59b	Gas jet – back burner	P06531001A	1
60	Back burner extension tube	P03717039B	1
61	Back burner wind shield panel	P06905029B	1
62	Gas valve – back burner	P03222131A	1
63	Door guide plate	P05510024G	1
64	Lighting stick	P05507031E	1
65	Side burner hose bracket	P03327028Q	2
66	Gas fitting	P03904001A	1

RINNAI NEW ZEALAND. LTD

Head Office: 691 Mt. Albert Rd, Royal Oak, Auckland.
PO Box 24068.
Tel (09) 625 4285. Fax (09) 624 3018.
Internet: www.rinnai.co.nz
Email: sales@rinnai.co.nz

*For your local
Service Centre
contact:* 0800 RINNAI (0800 746624).

