



**Rinnai INFINITY gas continuous flow water heating**  
Specification guide: A-Series, EF26, HD49, and N-Series

**Rinnai**

---

# Important

---

Rinnai is constantly improving its products, and as such, information and specifications are subject to change without notice. For the most up-to-date information, go to [www.rinnai.co.nz](http://www.rinnai.co.nz).

## Help is here

For more information about buying, using, and servicing of Rinnai appliances call 0800 RINNAI (0800 746 624).

Rinnai New Zealand Limited  
105 Pavilion Drive, Mangere, Auckland  
PO Box 53177, Auckland Airport, Auckland 2150

Phone: 09 257 3800  
Email: [info@rinnai.co.nz](mailto:info@rinnai.co.nz)  
Web: [www.rinnai.co.nz](http://www.rinnai.co.nz)  
[www.youtube.com/rinnainz](http://www.youtube.com/rinnainz)  
[www.facebook.com/rinnainz](http://www.facebook.com/rinnainz)



---

# Contents

---

Leaders in gas continuous flow .....	4
Rinnai INFINITY range .....	5
What is continuous flow.....	6
Model selection for residential applications.....	7
Location of a Rinnai INFINITY.....	8

## **Product specification pages**

Rinnai INFINITY A-Series.....	10
Rinnai INFINITY EF26.....	12
Rinnai INFINITY HD49 and HD250 range.....	14
Rinnai INFINITY N-Series .....	16
Rinnai INFINITY accessory matrix .....	18
Rinnai INFINITY internal flueing .....	20

## **Rinnai INFINITY accessory product pages**

Digital controllers.....	26
Metal recess box .....	28
Pipe covers.....	29
Rinnai INFINITY flue diverters.....	30
N-Series N56kWi flue diverter kit.....	32
Security bracket.....	33
Commercial error switch.....	34
EZ HD connect cable.....	34
N-Series cascade cable, and pump cable.....	35
HD manifolding (MECS).....	34

## **Appendices**

Appendix 1: Water flow and gas usage .....	38
Appendix 2: Rinnai INFINITY inbuilt frost protection .....	46
Appendix 3: Gas boosted solar .....	47
Appendix 4: Rinnai INFINITY Limited Warranty .....	48
Appendix 5: LPG gas bottle consumption and clearances.....	52
Appendix 6: The future of gas in New Zealand .....	53

# Leaders in gas continuous flow

When you turn on a tap you want water at the right temperature fast, which is why over the years we've devoted considerable time and resource to leading edge research and development.

We were the first to introduce continuous flow technology and have been tirelessly working on improving this ever since.





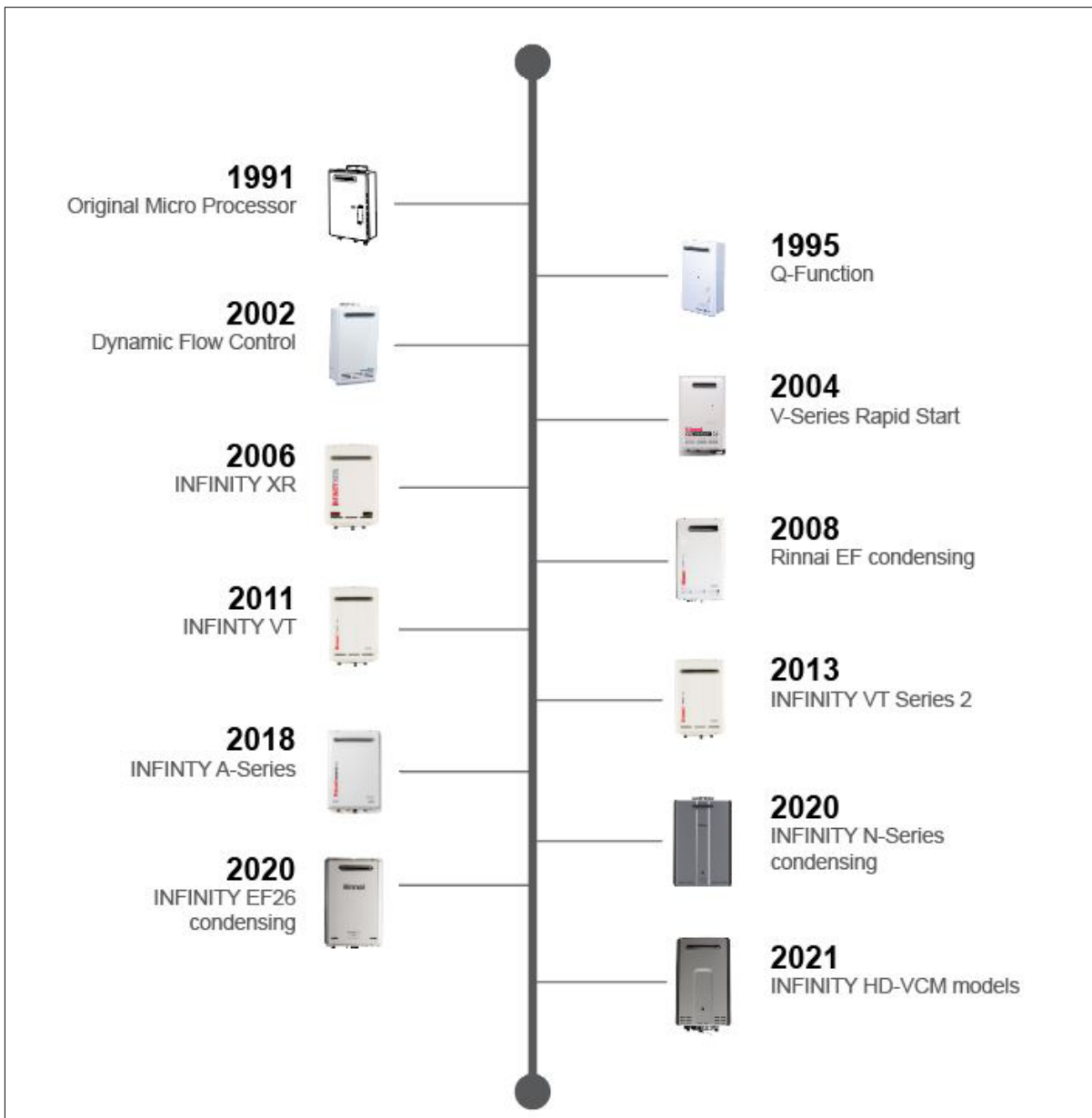

## Rinnai INFINITY continuous flow technology timeline



# Rinnai INFINITY range

The Rinnai INFINITY range is made up of four categories to cater for a variety of hot water demands and installation requirements.

Category	Suitability	
Rinnai INFINITY <b>A-Series</b> Improved accessibility for easier and faster service	Residential applications only	
Rinnai INFINITY <b>HD</b> Heavy duty on demand for demanding jobs	Residential and commercial applications	
Rinnai INFINITY <b>N-Series</b> Condensing technology to deliver higher efficiencies.	Residential and commercial applications	
Rinnai INFINITY <b>EF26</b> Condensing technology, replacing the EF24.	Residential applications only	

Model	Mounting position	Input	Output	Thermal efficiency on high	Status monitor
A16	External	16.3-124 MJ/h	27.8 kW	80.5%	No
A20	External	19.9-156 MJ/h	34.9 kW	80.5%	No
A24	External	16.3-184 MJ/h	42.0 kW	81%	No
A26	External	16.3-199 MJ/h	44.5 kW	80.5%	No
A28i	Internal	11.0-210 MJ/h	48.8 kW	83.5%	Yes
EF26	External	16.3-175 MJ/h	44.5kW	91.5%	No
HD49kWi	Internal	11.0-210 MJ/h	48.8 kW	83.5%	Yes
HD49kWe	External	11.0-210 MJ/h	48.8 kW	83.5%	Yes
HD250	External	20.0-249 MJ/h	57.8 kW	83%	No
N56kWi	Internal	16.0-209 MJ/h	55.5 kW	97%	Yes
N56kWe	External	16.0-209 MJ/h	55.5 kW	97%	Yes

## Service and maintenance

For reliable operation Rinnai INFINITY continuous flow water heaters in residential applications should be serviced every two years. For commercial applications Rinnai has a maintenance and servicing schedule, please contact us for more information.



# What is continuous flow?

A continuous flow hot water system only heats water when it passes through the unit. It will deliver heated water at a predetermined flow rate, depending on the model, as long as the unit is connected to power and gas.

## General principle of operation

Each Rinnai INFINITY has a number of components that control the water temperature and water flow. These are:

- PCB (onboard computer)
- water flow control valve
- water flow sensor
- modulating gas valve
- outlet water temperature sensor

When a tap is turned on the unit senses the need to start. The combustion fan starts, ignition begins (electronic requiring electricity), and the gas valve opens. Once the flame is established the appliance will heat the water through the heat exchanger (as required) until the tap is turned off.

They do this by preheating the incoming water through the transfer of heat from the exhaust gas, which in a standard unit would otherwise be wasted.

Water then flows to the primary heat exchanger and is heated. As the water is already preheated it uses less gas to reach the required temperature.

## What is condensing continuous flow?

The Rinnai N-Series and EF26 utilise condensing technology to deliver higher efficient water heaters, requiring less gas to operate. These water heaters, via a secondary heat exchanger, unlock energy that would otherwise be wasted.

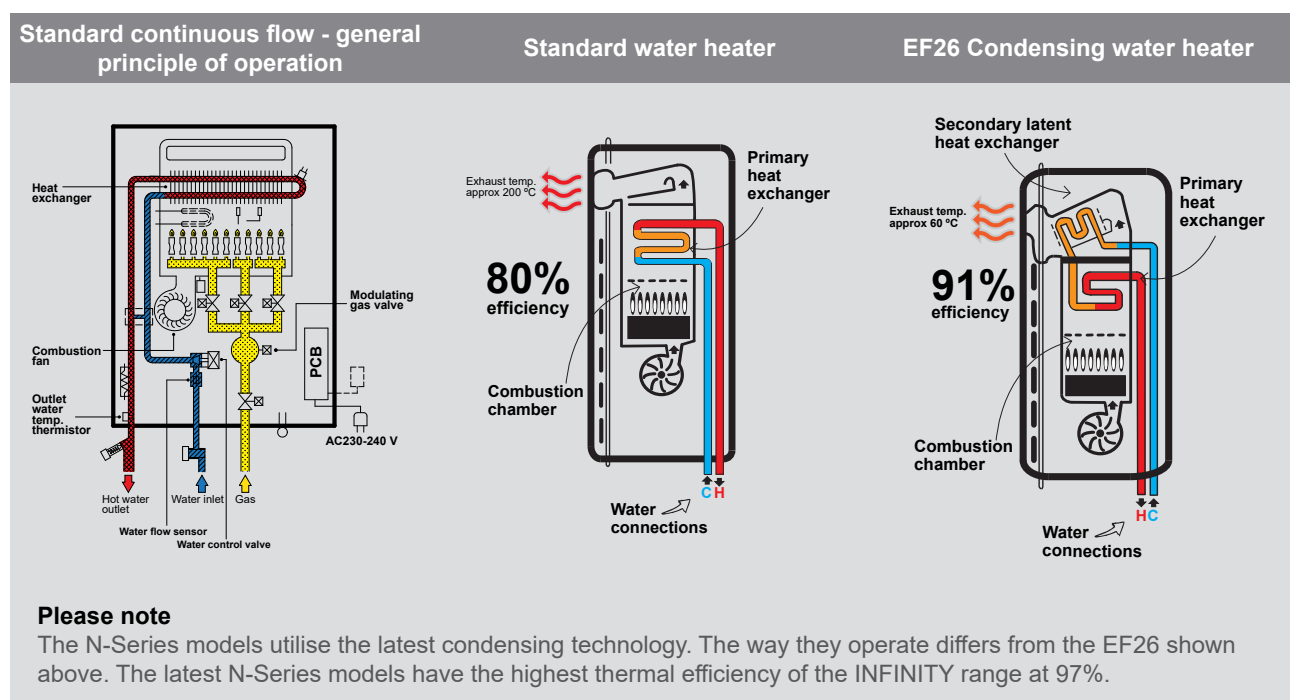

# Model selection for residential applications

When specifying residential applications there are some questions you need to ask when selecting a model or models. Keep in mind future requirements of the building. Water heating solutions should be designed to the number of hot water outlets and not the number of people.

## How many bathrooms?

An A16 or A20 unit may be suitable for a one bathroom home, a two or three bathroom home will need a larger Rinnai INFINITY, or even multiple units.

## Where are the bathrooms and other hot water outlets in the building?

Where are the bathrooms and other hot water outlets in relation to where the water heater is to be installed. In most cases it is better to site the Rinnai INFINITY closer to the kitchen where there is an immediate demand for hot water. If bathrooms are situated at opposite ends of the house two units may be required.

## Simultaneous demand?

How likely will hot water outlets, such as showers, be used at the same time?

Scenario one: Two bathroom home with a couple who rarely use the second shower—an A20 may be suitable.

Scenario two: Two bathroom home with a

family of five who fight for two showers in the morning—a larger Rinnai INFINITY would be needed.

## What type of tapware is installed?

There is a large range of tapware in the market, some with very high flow rates. The main consideration is the type of shower rose installed and how many litres it puts out—typical flow rates for showers is around 8-12 L/min. This needs to be factored when determining the model. To measure the flow rate of a shower, hold a bucket under the shower rose for one minute and measure the water volume.

## Location in New Zealand?

Ambient water temperatures will vary throughout the country, especially in winter. This is important when determining incoming water temperature and the temperature required at the hot water outlet, as this will affect how much hot water the unit can deliver. For more information refer to Appendix 1 on p.38 and the below model selection graph.

### Model selector example

Determine the hot water outlets that will run simultaneously and list the flow rates against them.

Hot water outlet	Typical flow rate	Worked example
Bathroom 1	9 L/min	9 L
Bathroom 2	9 L/min	9 L
Kitchen	6 L/min	6 L
Laundry	6 L/min*	
Other	Allow 6 L/min	
<b>TOTAL</b>		<b>24 L</b>

\* Some washing machines, particularly front loaders, have a cold-only connection as they have an internal heater. Hot water in this instance would not need to be factored into this calculation.

In the column for the geographical region move down until a number bigger than your total appears.

Warm (L/min)	Mild (L/min)	Cool (L/min)	A-Series	HD	EF26 & N-Series
16	13	11	16	HD49 (28)	EF26 (26)
20	17	14	20	HD49 (28)	EF26 (26)
24	20	17	24	HD49 (28)	EF26 (26)
26	22	19	26	HD49 (28)	N56 (32)
30	26	22	26	HD250 (32)	N56 (32)
32	27	23	28i	HD250 (32)	N56 (32)

Read across the model, e.g. for 24 litres per minute in the mild zone an A26 is selected. If you find the flow rate is greater than the figures listed in the table please contact Rinnai for advice. Multiple units or an alternative hot water heating solution may be required.



# Location of a Rinnai INFINITY

To provide safe and effective water heating it is important to adhere to all the relevant gas installation standards. If in doubt it pays to consult a licensed gasfitter to double check where the unit can be located.

## General installation considerations

The Rinnai INFINITY should be placed as close as possible to the most frequently used hot water outlet(s) to minimise the delay for hot water. In most cases it's better to site the unit closer to the kitchen where there is an immediate demand for hot water.

For installations where the distance between the water heater and outlets is considerable, a flow and return system with a buffer tank can be used to minimise the waiting time for hot water. Alternatively multiple units can be strategically placed to serve different outlets.

## Operating noise

Some people are susceptible to low level noise. Rinnai INFINITY units operate at around 50-54 dB(A). This needs to be considered if locating the appliance near a bedroom.

## Easy access

All continuous flow water heaters must be installed so that access can be gained for servicing and repair without hazard or undue difficulty.

If mounting the unit at height the owner must arrange permanent and safe access, or provide another means of safe access such as scissor or boom lifts.

## External models

External models are designed for outdoor installations only. They must be located above ground where products of combustion can be naturally dispersed. They should not be in enclosed areas as the unit can suffocate on its own flue gases, which will cause the unit to malfunction. Refer to the general flue clearances diagram below.

## Internal models

Internal models are designed for indoor installations only. They are a flued appliance. They may be installed in an enclosure if the requirements of AS/NZS 5601.1 are met. An enclosure is defined as a compartment, enclosed area, or partitioned off space primarily used for the installation of the appliance.



Example of an internal unit installed in a cupboard - Rinnai Auckland showroom

For internal units we recommend a 600 mm clearance in front of the unit for servicing access. This can be reduced to 50 mm if installed in a cupboard, refer clearances below.

**GENERAL FLUE CLEARANCES:**

Dim.	A-Series, EF26	N56kWe, HD49kWe <sup>1</sup> , HD250
A	Min. 300 mm	Min. 500 mm
B	Min. 300 mm	Min. 500 mm
C	Min. 1.5 m	Min. 1.5 m
D	Min. 500 mm	Min. 500 mm
E	Min. 300 mm	Min. 300 mm
F	Min. 300 mm*	Min. 300 mm <sup>2</sup>
G	Min. 300 mm	Min. 300 mm

**External models**

**Internal models**

Below eaves, balconies, and other projections, min. 300 mm.  
 From a gas meter 1000 mm. From an electricity meter or fuse box, min. 500 mm.

<sup>1</sup> If the HD49kWe is downrated to a 26 L unit (MJ rating decreases) then the clearances shift to the A-Series / EF26 column  
<sup>2</sup> Rinnai recommend 1.5 m to give enough clearance for the pipe work, and to safely expel flue gases.



---

# Rinnai INFINITY

product specification pages

---



## Instant vs continuous flow hot water

If an outlet is more than 15 m away from the INFINITY there could be a time delay for hot water of approximately 10-15 seconds. To minimise hot water delivery times, pipe sizing, INFINITY model selection and location are important. Consult a licensed gasfitter for more information.

# Rinnai INFINITY A-Series

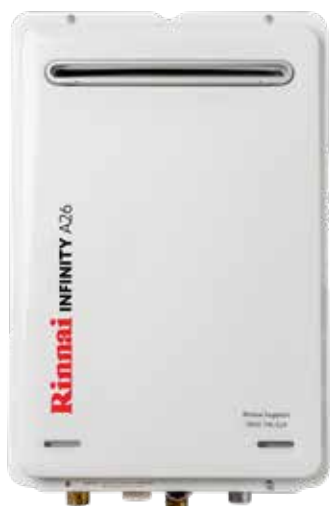

## Description

Designed and made in Japan, the Rinnai INFINITY A-Series are gas continuous flow hot water heaters with inbuilt frost protection. They have electronic ignition and require electricity to operate. They are factory preset to deliver water at 55 °C. The internal unit (A28i) is a room sealed appliance.

## Scope of use

Suitable for RESIDENTIAL applications only. The external units are designed to be externally mounted on an outside wall. The internal A28i unit is designed for internal installations only and can be installed in an enclosure if the requirements of AS/NZS 5601.1 are satisfied. They are designed to be located as close as practicable to the most frequently used hot water outlets to reduce the delay for hot water delivery.

Not suitable as a spa or swimming pool heater, or for hydronic applications. The **external** units are also not suitable as a gas boost for solar installations as the temperature cannot be set high enough.

Hard or acidic water will need to be treated to use this product.



	A16 external	A20 external	A24 external	A26 external	A28i <sup>1</sup> internal
<b>REU number</b>	A1620WG-ZK	A2024WG-ZK	A2426WG-ZK	A2626WG-ZK	VCM2837FF-ZK
<b>Code Natural Gas</b>	INFA16N	INFA20N	INFA24N	INFA26N	INFA28FFN
<b>Code LPG</b>	INFA16L	INFA20L	INFA24L	INFA26L	INFA28FFL
<b>Thermal efficiency on high</b>	80.5%	80.5%	81%	80.5%	83.5%
<b>Hot water capacity<sup>2</sup></b>	1.5-20 L/min	1.5-24 L/min	1.5-26 L/min	1.5-26 L/min	1.4-37 L/min
<b>Hot water capacity at a 25° rise</b>	16 L/min 960 L/h	20 L/min 1200 L/h	24 L/min 1440 L/h	26 L/min 1560 L/h	28 L/min 1680 L/h
<b>Input</b>	16.3-124 MJ/h	19.9-156 MJ/h	16.3-184 MJ/h	16.3-199 MJ/h	11-210 MJ/h
<b>Output</b>	27.8 kW	34.9 kW	42 kW	44.5 kW	48.8 kW
<b>Weight</b>	13 kg	14 kg	15 kg	15 kg	21 kg
<b>Nominal operating pressure</b>	120-1000 kPa	160-1000 kPa	200-1000 kPa	200-1000 kPa	200-1000 kPa
<b>Connection - hot</b>	R ½ (15 mm)	R ¾ (20 mm)	R ¾ (20 mm)	R ¾ (20 mm)	R ¾ (20 mm)
<b>Connection - cold</b>	R ½ (15 mm)	R ¾ (20 mm)	R ¾ (20 mm)	R ¾ (20 mm)	R ¾ (20 mm)
<b>Connection - gas</b>	R ¾ (20 mm)	R ¾ (20 mm)	R ¾ (20 mm)	R ¾ (20 mm)	R ¾ (20 mm)
<b>Ingress protection rating</b>	IPX4	IPX4	IPX4	IPX4	IPX2
<b>Noise level (1 m) away</b>	54 dB(A)	55 dB(A)	54 dB(A)	55 dB(A)	54 dB(A)
<b>Power consumption</b>					
• normal	47 W	58 W	56 W	66 W	66 W
• standby	2 W	2 W	2 W	2 W	2 W
• frost protection	68 W	68 W	68 W	68 W	104 W

<sup>1</sup> The A28i model, while part of the A-Series range, looks different to the external units—refer image on p.5. This model is suitable as a gas boost for solar installations as the temperature can be set to 75 °C—refer system layout diagram on p.47.

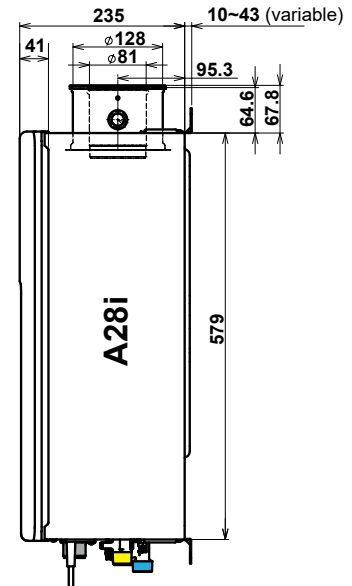
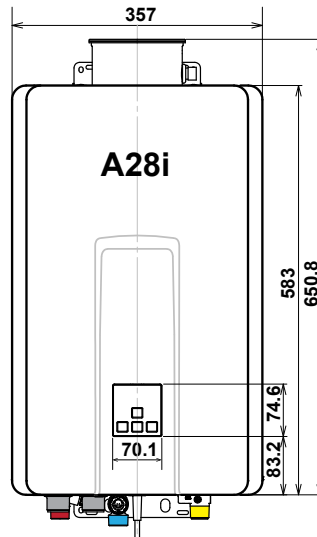
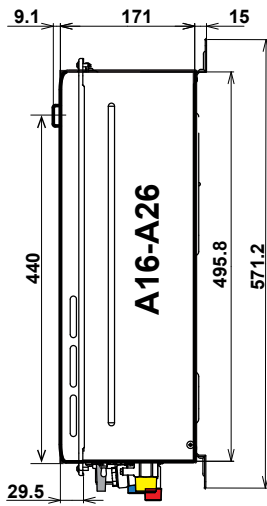
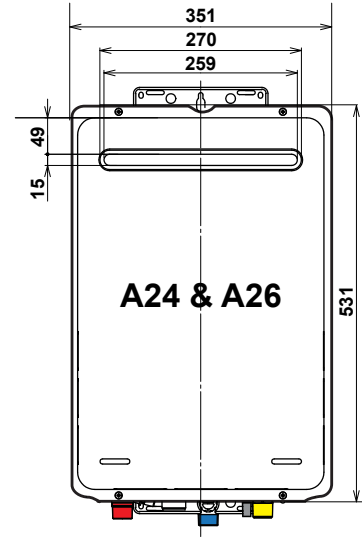
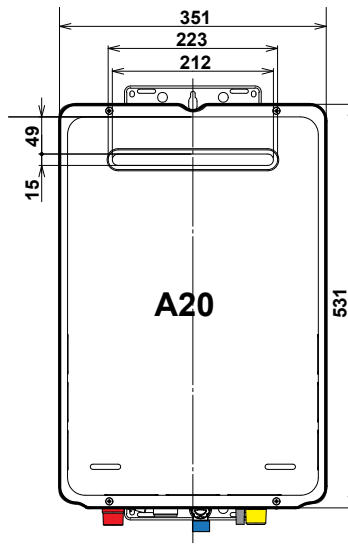
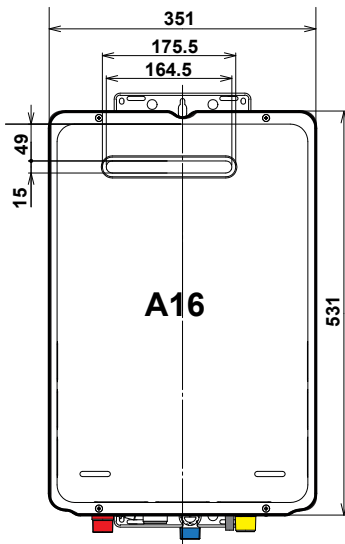
<sup>2</sup> The higher figures for the A16, A20, A24, and A28i are only applicable in areas where the incoming water temperatures are high, for example 20 °C. Rather than all the water going through the heat exchanger, some of the water will go through the bypass tube allowing a greater capacity of water to be delivered.



### Connection dimensions under unit

	A16-A26	A28i
		
<b>1</b>	Gas connection from wall Gas connection from centre Gas connection length from base	89 mm 89 mm 36.4 mm
<b>2</b>	Cold water inlet from wall Cold water inlet from centre Cold water inlet length from base	60.1 mm 27 mm 46.1 mm
<b>3</b>	Hot water outlet from wall Hot water outlet from centre Hot water outlet length from base	81.1 mm 110 mm 36.3 mm

# Rinnai INFINITY EF26



## Description

Designed and made in Japan, the Rinnai INFINITY EF26 is an external gas condensing continuous flow hot water heater with inbuilt frost protection. It has electronic ignition and requires electricity to operate. It is factory preset to deliver water at 55 °C (maximum set temperature is 65 °C).

## Scope of use

Suitable for RESIDENTIAL applications only. The EF26 is designed to be externally mounted on an outside wall and located as close as practicable to the most frequently used hot water outlets to reduce the delay for hot water delivery.

It is not suitable as a spa or swimming pool heater, or for hydronic applications. It is also not suitable as a gas boost for solar installations as the temperature cannot be set high enough.

Hard or acidic water will need to be treated to use this product.

<b>REU number</b>	E2626W-ZK
<b>Code Natural Gas</b>	INFEF26N
<b>Code LPG</b>	INFEF26L
<b>Thermal efficiency on high</b>	91.5%
<b>Hot water capacity</b>	1.5-26 L/min
<b>Hot water capacity at a 25° rise</b>	26 L/min 1560 L/h
<b>Input</b>	16.3-175 MJ/h
<b>Output</b>	44.5 kW
<b>Weight</b>	18 kg
<b>Nominal operating pressure</b>	220-1000 kPa
<b>Connection - hot</b>	R ¾ (20 mm)
<b>Connection - cold</b>	R ¾ (20 mm)
<b>Connection - gas</b>	R ¾ (20 mm)
<b>Connection - condensate</b>	R ½ (15 mm)
<b>Ingress protection rating</b>	IPX5
<b>Noise level (1 m) away</b>	50 dB(A) approx.
<b>Power consumption</b>	
• normal	63 W
• standby	2 W
• automatic frost protection	92 W

## Please note

Joining units together is not possible. The EF26 model is unable to be electronically manifolded.

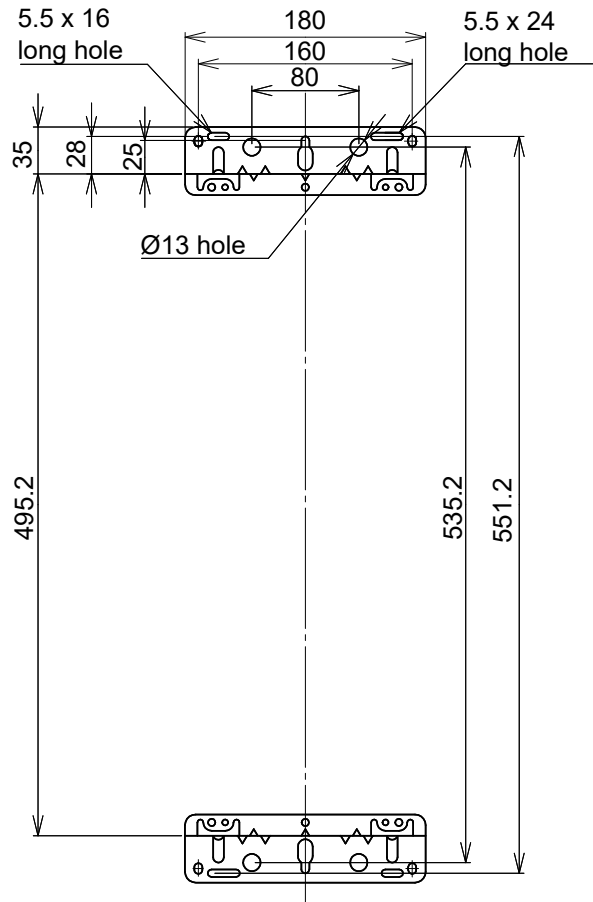
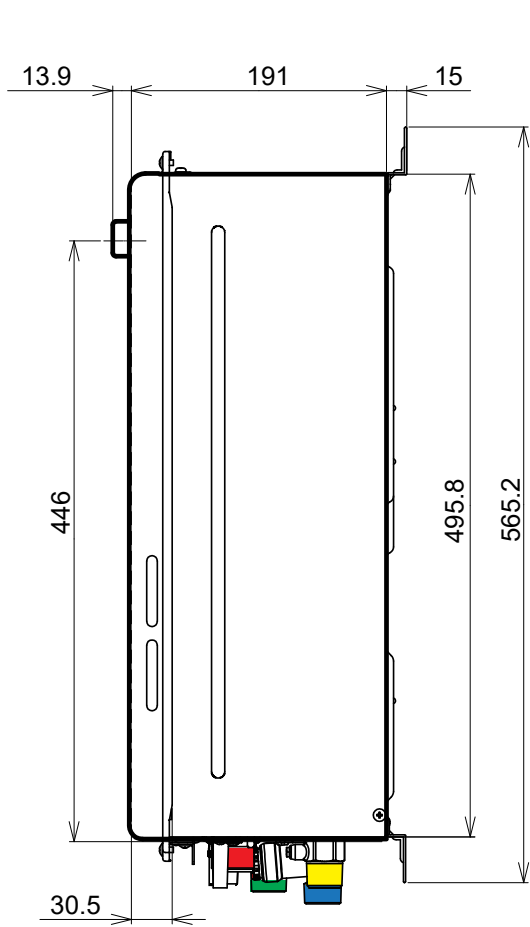
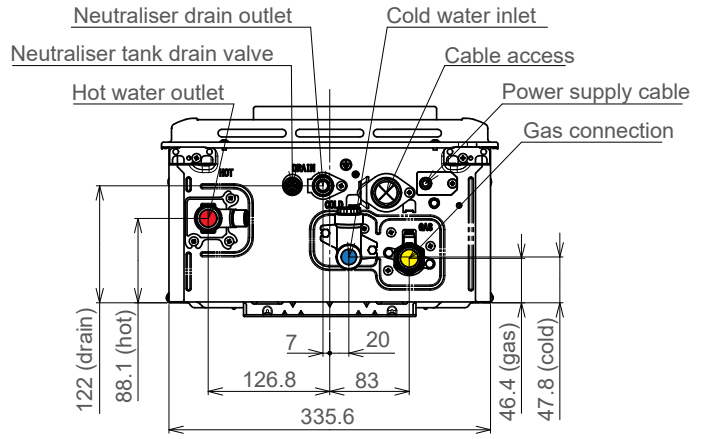
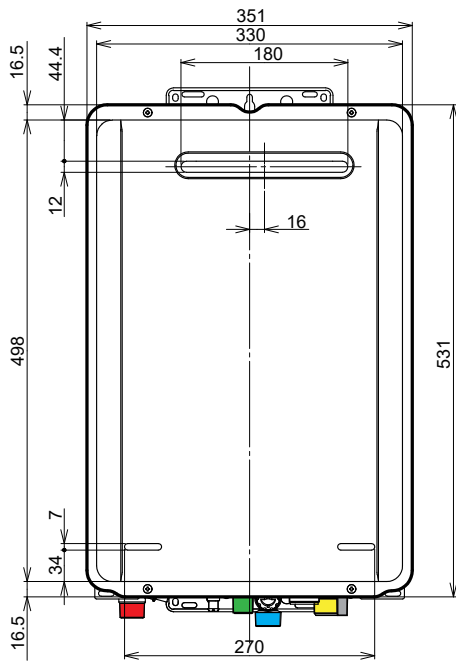



# Rinnai INFINITY HD49 and HD250



HD49kWe external model pictured

## Description



Designed and made in Japan, the Rinnai INFINITY HD units are gas continuous flow hot water heaters with inbuilt frost protection. They have electronic ignition and require electricity to operate. The internal unit is a room sealed appliance. The INFINITY HD250 is factory preset to 55 °C, the HD49 units are factory preset to 75 °C.

## Scope of use

Suitable for residential and commercial applications. The external HD49kWe / HD250 units are designed to be externally mounted on an outside wall. The internal HD49kWi is designed for internal installations only and can be installed in an enclosure if the requirements of AS/NZS 5601.1 are satisfied. They are designed to be located as close as practicable to the most frequently used hot water outlets to reduce the delay for hot water delivery.

They are not suitable as a spa or swimming pool heater, or for hydronic applications.

Hard or acidic water will need to be treated to use this product.

	HD49kWe external	HD49kWi internal	HD250 external
			
<b>REU number</b>	VCM2837WC-ZK	VCM2837FFC-ZK	VR3237WG-ZK(S)
<b>Code Natural Gas</b>	INFHD49N	INFHD49FFN	INFHD250HNCN
<b>Code LPG</b>	INFHD49L	INFHD49FFL	INFHD250HNCL
<b>Thermal efficiency on high</b>	83.5%	83.5%	83%
<b>Hot water capacity<sup>1</sup></b>	1.4-37 L/min	1.4-37 L/min	3.2-37 L/min
<b>Hot water capacity at a 25° rise</b>	28 L/min 1680 L/h	28 L/min 1680 L/h	32 L/min 1920 L/h
<b>Input</b>	11-210 MJ/h	11-210 MJ/h	20-249 MJ/h
<b>Output</b>	48.8 kW	48.8 kW	57.8 kW
<b>Weight</b>	20 kg	21 kg	29 kg
<b>Nominal operating pressure</b>	200-1000 kPa	200-1000 kPa	200-1000 kPa
<b>Connection - hot</b>	R ¾ (20 mm)	R ¾ (20 mm)	R ¾ (20 mm)
<b>Connection - cold</b>	R ¾ (20 mm)	R ¾ (20 mm)	R ¾ (20 mm)
<b>Connection - gas</b>	R ¾ (20 mm)	R ¾ (20 mm)	R ¾ (20 mm)
<b>Ingress protection rating</b>	IPX5	IPX2	IPX4
<b>Noise level (1 m) away</b>	52 dB(A)	54 dB(A)	50 dB(A)
<b>Power consumption</b>			
• normal	66 W	95 W	72 W
• standby	2 W	2 W	2 W
• automatic frost protection	104 W	120 W	116 W

<sup>1</sup> The higher figures are only applicable in areas where the incoming water temperatures are high, for example 20 °C. Rather than all the water going through the heat exchanger, some of the water will go through the bypass tube allowing a greater capacity of water to be delivered.



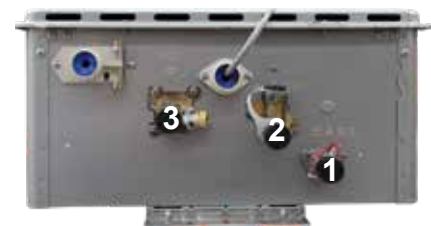
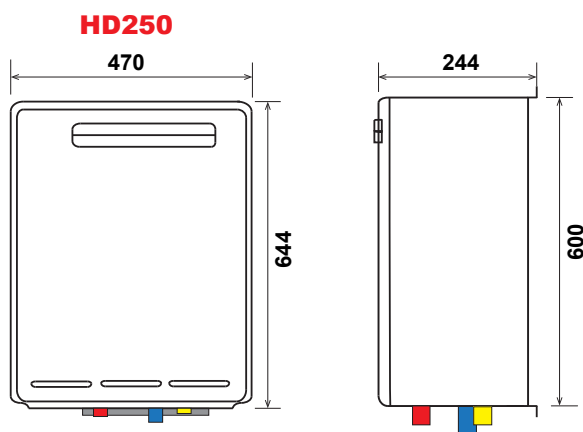
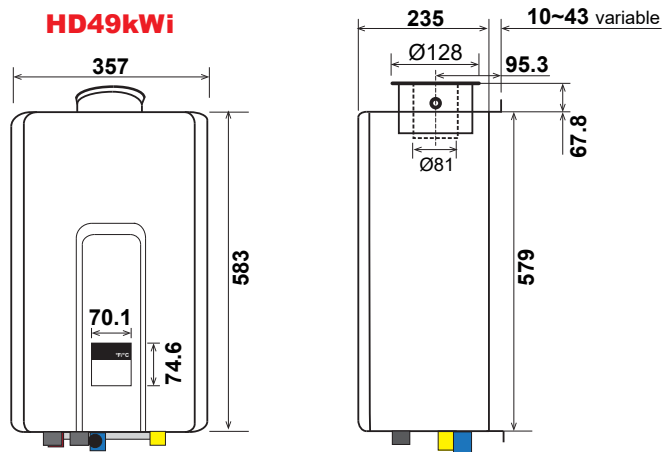
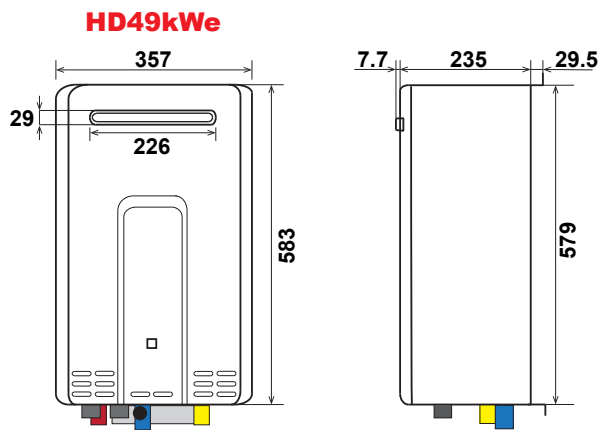

### Connection dimensions under unit

	HD49kWe	HD49kWi	HD250
<b>1</b> Gas connection from wall	74.5 mm	89 mm	61 mm
Gas connection from centre	89 mm	89 mm	110 mm
Gas connection length from base	36.4 mm	36.4 mm	41 mm
<b>2</b> Cold water inlet from wall	45.6 mm	60.1 mm	99 mm
Cold water inlet from centre	27 mm	27 mm	52 mm
Cold water inlet length from base	46.1 mm	46.1 mm	51 mm
<b>3</b> Hot water outlet from wall	66.6 mm	81.1 mm	115 mm
Hot water outlet from centre	110 mm	110 mm	61 mm
Hot water outlet length from base	36.3 mm	36.3 mm	42 mm

# Rinnai INFINITY N-Series



N56kWe external model pictured

## Description

Designed and made in Japan, the Rinnai INFINITY N-Series are condensing continuous flow water heaters with inbuilt frost protection. They have electronic ignition and require electricity to operate. The internal unit is a room sealed appliance.



The INFINITY N-Series units are factory preset to 55 °C.

## Scope of use

Suitable for residential and commercial applications. The external N56kWe is designed to be externally mounted on an outside wall. The internal 56kWi is designed for internal installations only and can be installed in an enclosure if the requirements of AS/NZS 5601.1 are satisfied. They are designed to be located as close as practicable to the most frequently used hot water outlets to reduce the delay for hot water delivery.

They are not suitable as a spa or swimming pool heater, for hydronic applications, or for domestic ring main applications<sup>1</sup>.

Hard or acidic water will need to be treated to use this product.

	N56kWi internal	N56kWe external
		
<b>REU number</b>	N3237FFUC-ZK	N3237WC-ZK
<b>Code Natural Gas</b>	INFN56FFN	INFN56N
<b>Code LPG</b>	INFN56FFL	INFN56L
<b>Thermal efficiency on high</b>	97%	97%
<b>Hot water capacity<sup>2</sup></b>	1.5-37 L/min	1.5-37 L/min
<b>Hot water capacity at a 25° rise</b>	32 L/min 1920 L/h	32 L/min 1920 L/h
<b>Input</b>	16-209 MJ/h	16-209 MJ/h
<b>Output</b>	55.5 kW	55.5 kW
<b>Weight</b>	29 kg	29 kg
<b>Nominal operating pressure</b>	300-1000 kPa	300-1000 kPa
<b>Connection - hot</b>	R ¾ (20 mm)	R ¾ (20 mm)
<b>Connection - cold</b>	R ¾ (20 mm)	R ¾ (20 mm)
<b>Connection - gas</b>	R ¾ (20 mm)	R ¾ (20 mm)
<b>Connection - condensate</b>	R ½ (15 mm)	R ½ (15 mm)
<b>Ingress protection rating</b>	IPX5	IPX5
<b>Noise level (1 m) away</b>	49 dB(A)	54 dB(A)
<b>Power consumption</b>		
• <b>normal</b>	70 W (NG), 85 W (LPG)	70 W (NG), 85 W (LPG)
• <b>standby</b>	2 W	2 W
• <b>automatic frost protection</b>	150 W	100 W

<sup>1</sup> If a domestic ring main is req. we have a plumbing configuration, refer to the N-Series website product page for more information

<sup>2</sup> The higher figures are only applicable in areas where the incoming water temperatures are high, for example 20 °C. Rather than all the water going through the heat exchanger, some of the water will go through the bypass tube allowing a greater capacity of water to be delivered.

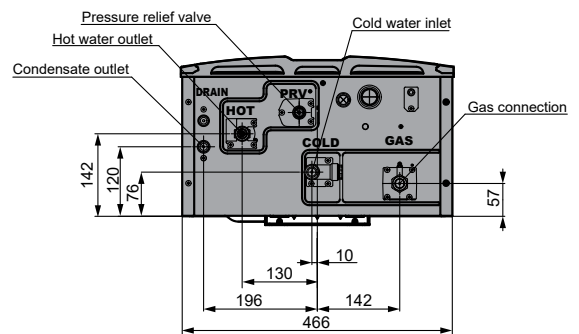
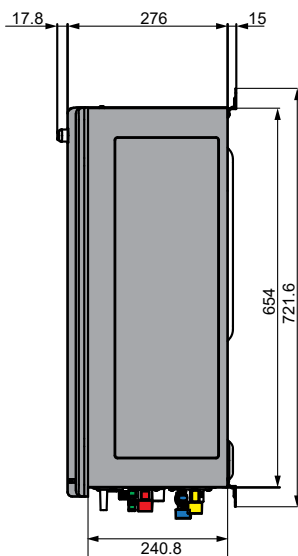
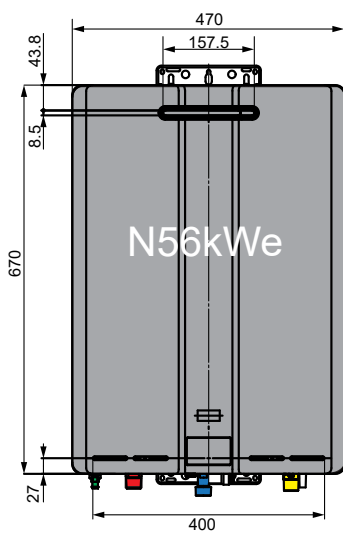
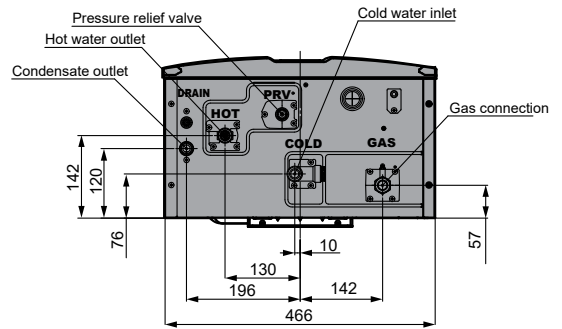
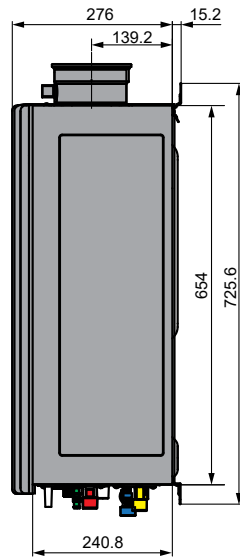
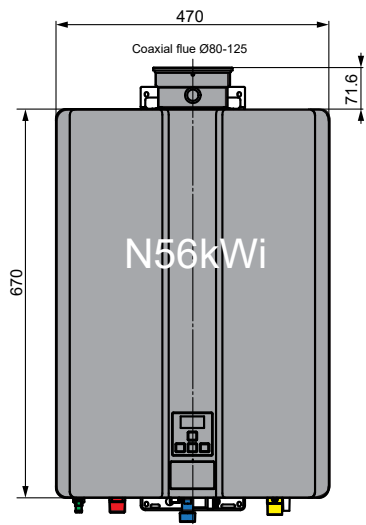

## Manifolding

N56 models can be electronically connected (up to 24 units) using the N-Series cascade cable.

# Rinnai INFINITY accessories matrix

CONTROLLERS		
Part number	Description	Image
MC601A	<b>Compact controller</b> Suitable for all Rinnai INFINITY units	1
BC100V1Z	<b>Bathroom Deluxe controller</b> Suitable for all Rinnai INFINITY units	2
MC100V1Z	<b>Kitchen Deluxe controller</b> Suitable for all Rinnai INFINITY units	3
RECESS BOX		
R1405	<b>Metal recess box</b> Suitable for all A-Series external models	4
R1407	<b>Metal recess box</b> Suitable for EF26, HD49kWe, and HD250	4
There is no recess box available for the N56kWe due to the significant size of the unit.		
PIPE COVERS		
R1385	<b>A-Series white pipe cover</b> Suitable for all A-Series external models	5
R1402SC	<b>HD250 silver pipe cover</b> Suitable for the HD250 model only	6
R1415	<b>N-Series gunmetal grey pipe cover</b> Suitable for the N56kWe / N56kWi models only	7
R1416	<b>EF26 white pipe cover</b> Suitable for the EF26 only	8
R1417	<b>HD49 silver pipe cover</b> Suitable for the HD49kWe / HD49kWi models only	9
SECURITY BRACKET		
ACC1395	<b>Security bracket</b> Suitable for ALL Rinnai INFINITY models	11
FLUE DIVERTERS		
FDS16A	<b>Sideways A16 flue diverter</b> Suitable for the A16 model only	12
FDS20	<b>Sideways A20 flue diverter</b> Suitable for the A20 model only	12
FDS24	<b>Sideways A24/A26 flue diverter</b> Suitable for the A24 and A26 models only	12
FDS26E	<b>Sideways EF26 flue diverter</b> Suitable for the EF26 model only	13
FDU16	<b>Upwards A16 flue diverter</b> Suitable for the A16 model only	14
FDU24	<b>Upwards A24/A26 flue diverter</b> Suitable for the A24 and A26 models only	14
FDU32	<b>Upwards HD250 flue diverter</b> Suitable for the HD250 model only	14
FFP100DIV	<b>N-Series flue diverter</b> Suitable for the N56kWi internal model only	15
There are no flue diverters for the HD49kWe		

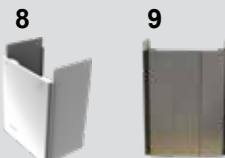
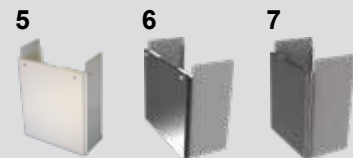

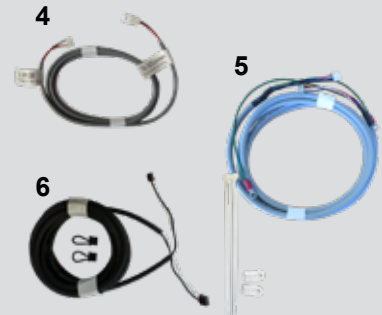
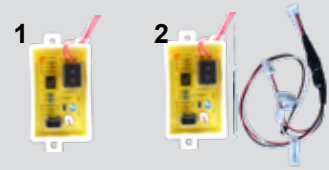

ERROR SWITCHES		
Part number	Description	Image
R1070	<b>HD error indication switch</b> Suitable for HD49kWe, HD49kWi and HD250 models only	1
REUOPU3	<b>N-Series error indication switch</b> Suitable for N56kWe and N56kWi models only	2
N-SERIES PUMP ACCESSORIES		
R1071	<b>N-Series pump cable 2 m</b> Suitable for N56kWe and N56kWi models only	3
CONNECTING CABLES		
REUEZC	<b>EZ connect cable</b> Suitable for HD49kWe, HD49kWi, A28i, and HD250 models only	4
REUMSBM	<b>HD internal master manifold</b> Suitable for HD49kWe, HD49kWi, and HD250 models only	-
REUMSBMB	<b>HD external master manifold</b> Suitable for HD49kWe, HD49kWi, and HD250 models only	-
REUMSBC1	<b>HD manifold slave cable</b> Suitable for HD49kWe, HD49kWi, and HD250 models only	5
REUMSBC2	<b>HD manifold joiner</b> Suitable for HD49kWe, HD49kWi, and HD250 models only	-
REUCSAC1	<b>N-Series cascade cable</b> Suitable for N56kWe and N56kWi models only	6



# Rinnai INFINITY internal flueing

With the introduction of the high efficiency N56kWi internal water heater, we now have three flueing options. These flueing options are specific to the model of water heater and type of installation, they **CANNOT BE INTERCHANGED**.

Detailed in this section is a high level view of the options available and the flue components.

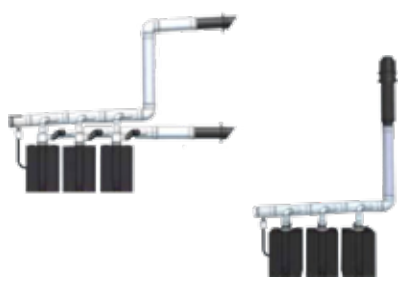
HD49kWi and A28i		N56kWi ONLY					N56kWi ONLY																																																																																																																																																																																																																									
Individual flueing		Individual flueing (concentric)					Common flueing																																																																																																																																																																																																																									
Stainless steel inner pipe and thermoplastic outer pipe		Polypropylene concentric flueing					Polypropylene common flueing																																																																																																																																																																																																																									
																																																																																																																																																																																																																																
<table border="1"> <thead> <tr> <th rowspan="2"></th> <th rowspan="2"></th> <th colspan="5">Number of bends</th> </tr> <tr> <th>0</th> <th>1</th> <th>2</th> <th>3</th> <th>4</th> </tr> </thead> <tbody> <tr><td rowspan="12">Flue length (m)</td><td>1</td><td></td><td></td><td></td><td></td><td></td></tr> <tr><td>2</td><td></td><td></td><td></td><td></td><td></td></tr> <tr><td>3</td><td></td><td></td><td></td><td></td><td></td></tr> <tr><td>4</td><td></td><td></td><td></td><td></td><td></td></tr> <tr><td>5</td><td></td><td></td><td></td><td></td><td></td></tr> <tr><td>6</td><td></td><td></td><td></td><td></td><td></td></tr> <tr><td>7</td><td></td><td></td><td></td><td></td><td></td></tr> <tr><td>9</td><td></td><td></td><td></td><td></td><td></td></tr> <tr><td>11</td><td></td><td></td><td></td><td></td><td></td></tr> <tr><td>13</td><td></td><td></td><td></td><td></td><td></td></tr> <tr><td>15</td><td></td><td></td><td></td><td></td><td></td></tr> </tbody> </table>				Number of bends					0	1	2	3	4	Flue length (m)	1						2						3						4						5						6						7						9						11						13						15						<table border="1"> <thead> <tr> <th rowspan="2"></th> <th rowspan="2"></th> <th colspan="5">Number of bends</th> </tr> <tr> <th>0</th> <th>1</th> <th>2</th> <th>3</th> <th>4</th> </tr> </thead> <tbody> <tr><td rowspan="16">Flue length (m)</td><td>1</td><td></td><td></td><td></td><td></td><td></td></tr> <tr><td>2</td><td></td><td></td><td></td><td></td><td></td></tr> <tr><td>3</td><td></td><td></td><td></td><td></td><td></td></tr> <tr><td>4</td><td></td><td></td><td></td><td></td><td></td></tr> <tr><td>5</td><td></td><td></td><td></td><td></td><td></td></tr> <tr><td>6</td><td></td><td></td><td></td><td></td><td></td></tr> <tr><td>7</td><td></td><td></td><td></td><td></td><td></td></tr> <tr><td>8</td><td></td><td></td><td></td><td></td><td></td></tr> <tr><td>9</td><td></td><td></td><td></td><td></td><td></td></tr> <tr><td>11</td><td></td><td></td><td></td><td></td><td></td></tr> <tr><td>12</td><td></td><td></td><td></td><td></td><td></td></tr> <tr><td>14</td><td></td><td></td><td></td><td></td><td></td></tr> <tr><td>15</td><td></td><td></td><td></td><td></td><td></td></tr> <tr><td>17</td><td></td><td></td><td></td><td></td><td></td></tr> <tr><td>18</td><td></td><td></td><td></td><td></td><td></td></tr> <tr><td>20</td><td></td><td></td><td></td><td></td><td></td></tr> </tbody> </table>							Number of bends					0	1	2	3	4	Flue length (m)	1						2						3						4						5						6						7						8						9						11						12						14						15						17						18						20						<table border="1"> <thead> <tr> <th></th> <th>Ø110 mm header and flue</th> <th>Ø110 mm header and Ø160 mm flue</th> </tr> </thead> <tbody> <tr> <td colspan="3">For every 90° bend used, subtract 3 m from the lengths below</td> </tr> <tr> <th>No. of water heaters</th> <th colspan="2">Maximum flue length</th> </tr> <tr> <td>2</td> <td>45 m</td> <td>45 m</td> </tr> <tr> <td>3</td> <td>45 m</td> <td>45 m</td> </tr> <tr> <td>4</td> <td>20 m</td> <td>45 m</td> </tr> <tr> <td>5</td> <td></td> <td>45 m</td> </tr> <tr> <td>6</td> <td></td> <td>45 m</td> </tr> <tr> <td>7</td> <td></td> <td>21 m</td> </tr> </tbody> </table>				Ø110 mm header and flue	Ø110 mm header and Ø160 mm flue	For every 90° bend used, subtract 3 m from the lengths below			No. of water heaters	Maximum flue length		2	45 m	45 m	3	45 m	45 m	4	20 m	45 m	5		45 m	6		45 m	7		21 m
				Number of bends																																																																																																																																																																																																																												
		0	1	2	3	4																																																																																																																																																																																																																										
Flue length (m)	1																																																																																																																																																																																																																															
	2																																																																																																																																																																																																																															
	3																																																																																																																																																																																																																															
	4																																																																																																																																																																																																																															
	5																																																																																																																																																																																																																															
	6																																																																																																																																																																																																																															
	7																																																																																																																																																																																																																															
	9																																																																																																																																																																																																																															
	11																																																																																																																																																																																																																															
	13																																																																																																																																																																																																																															
	15																																																																																																																																																																																																																															
			Number of bends																																																																																																																																																																																																																													
0			1	2	3	4																																																																																																																																																																																																																										
Flue length (m)	1																																																																																																																																																																																																																															
	2																																																																																																																																																																																																																															
	3																																																																																																																																																																																																																															
	4																																																																																																																																																																																																																															
	5																																																																																																																																																																																																																															
	6																																																																																																																																																																																																																															
	7																																																																																																																																																																																																																															
	8																																																																																																																																																																																																																															
	9																																																																																																																																																																																																																															
	11																																																																																																																																																																																																																															
	12																																																																																																																																																																																																																															
	14																																																																																																																																																																																																																															
	15																																																																																																																																																																																																																															
	17																																																																																																																																																																																																																															
	18																																																																																																																																																																																																																															
	20																																																																																																																																																																																																																															
	Ø110 mm header and flue	Ø110 mm header and Ø160 mm flue																																																																																																																																																																																																																														
For every 90° bend used, subtract 3 m from the lengths below																																																																																																																																																																																																																																
No. of water heaters	Maximum flue length																																																																																																																																																																																																																															
2	45 m	45 m																																																																																																																																																																																																																														
3	45 m	45 m																																																																																																																																																																																																																														
4	20 m	45 m																																																																																																																																																																																																																														
5		45 m																																																																																																																																																																																																																														
6		45 m																																																																																																																																																																																																																														
7		21 m																																																																																																																																																																																																																														

Important and detailed information on each of the flueing options is available in the flueing installation guides available on [www.rinnai.co.nz](http://www.rinnai.co.nz).





# Internal flueing guidelines

The flue terminal is to terminate in a location so as not to cause a nuisance, in accordance with AS/NZS 5601.



Polypropylene flueing CANNOT be used for the HD49kWi / A28i internal water heaters. Flue gases from these units run much hotter than the N-Series and there is risk of the plastic flue components melting.

## Flue fall back to the water heater

The flue terminal in all applications must FALL BACK towards the water heater and not towards to the flue terminal. The degree in which this occurs is dependent on the flueing application, refer below.

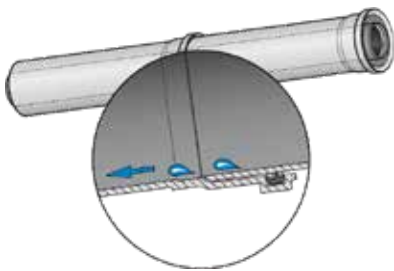

- **Stainless steel flueing (HD49kWi / A28i)**  
Slope horizontal flues back towards the water heater at a 20 mm fall per meter to drain condensate.
- **PP individual flueing (N56kWi)**  
Slope horizontal flues back towards the water heater at a 25 mm fall per meter to drain condensate.
- **PP common flueing (N56kWi)**  
Slope horizontal flues back towards the water heater at a 54 mm fall per meter to drain condensate.

## Condensate

The condensate trap (HD49kWi and A28i) or condensate drain (N56kWi) collects any condensate from the unit and prevents it entering the water heater and causing damage.

Condensate is a by-product of high efficiency gas combustion and is mildly acidic. For this reason copper tube and fittings must not be used as it will corrode. Instead Rinnai recommends plastic pipe and fittings such as UPVC or PE.

## Handling condensate for the HD49kWi /A28i

A condensate trap kit (FFSSCOND) is required for lengths over 1.5 m. If flueing is less than 1.5 m the flue spigot on top of the unit is capped using the drain tube cap supplied with the unit.

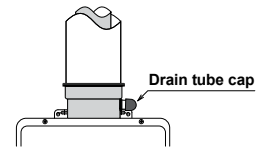

## Handling condensate for the N56kWi

A condensate trap kit is not needed for the N56kWi as there is a different method for draining condensate. As there is a continuous flow of condensate being produced the unit must be drained via a pipe to a suitable discharge point. Refer to the install guide for further information.

## Vertical terminations (all applications)

To ensure products of combustion are cleared adequate clearance from the building is required. The vertical cowl should have a 500 mm clearance from any part of the building. This also applies to steeped and pitched roofs, where the flue cowl should be 500 mm clear of the ridge line. An adequate flow of fresh air must exist around the flue cowl following installation.

Minimum clearances are shown in AS/NZS 5601.1.





## Flue supports

Ensure the flue is supported independently of the appliance by use of suitable clips or brackets in accordance with AS/NZS 5601.

For individual stainless steel and polypropylene flueing, flue supports are supplied with each roof cowl and flue pipe.

For polypropylene common flueing, flue supports are not provided with any component and must be ordered separately.

# Rinnai INFINITY HD49kW<sub>i</sub> / A28<sub>i</sub> internal flueing stainless steel flue kits and components

Code	Description	Image
FFSSKIT	Direct flue kit for horizontal installations—can be cut to size. Includes black and white wall seals.	
FFSSROOFCOWL	Roof cowl for vertical installations—can be cut to size. Includes three black UV components (1 collar adapter, 2 roof protectors (shown below)), for covering and protecting the white flue pipe from UV damage. Roof protector can also be ordered as a spare (12693, one protector). Kit also includes a flue pipe clamp to support the flue.	
FFSSPIPE1000	1000 mm flue pipe—can be cut to size. Includes Munzing ring to support the flue.	
FFSSBEND90	Single 90 degree bend.	
FFSSBEND45	Two 45 degree bends, sold as a pair.	
FFSSCOND	Condensate trap kit for the HD49kW <sub>i</sub> and A28 <sub>i</sub> ONLY. Comes with approximately 500 mm of black rubber hose, refer image below.	



# Rinnai INFINITY N56kWi concentric flueing polypropylene flue kits and components



Polypropylene flueing CANNOT be used for the HD49kWi / A28i internal water heaters. Flue gases from these units run much hotter than the N-Series and there is risk of the plastic flue components melting.

Code	Description	Image
FFP100HKIT	Direct flue kit for horizontal installations—can be cut to size. Includes horizontal adapter, black and white wall seals and a tube of centrocerin lubricant.	
FFP100VKIT	Vertical termination kit—can be cut to size. Includes the vertical adapter, which reduces the flue diameter from Ø80/120 mm to Ø60/100 mm, and black UV flue protectors, for covering and protecting the white flue pipe from UV damage.  Also includes a flue clamp to support the flue, and a tube of centrocerin lubricant.	
FFP100PIPE	1000 mm flue pipe—can be cut to size. Includes flue bracket to support the flue.	
FFP100HADAPT	Horizontal adapter 60/100, required in combination flueing where the flue starts off horizontally. The horizontal adapter connects into the flue spigot of the N56kWi.	
FFP100BEND	Two 45 degree bends, sold as a pair. One 90° bend equates to 3 m, and one 45° bend equates to 1.1 m.	
FFP100BRACKET	Flue bracket support—white. Purchased if additional support is required. Every length of flue should be supported.  Please note: The FFP100BRACKET is supplied with each flue pipe.	
FFP100PLATE	Inside wall plate—internal white wall plate/seal, used to tidy up any installation work. Comes as part of the FFP100HKIT, but can be ordered for other flueing applications. Comes in two pieces.	
FFP100SEAL	Typically only ordered if the inner seal has been damaged. For example we have had a couple of instances where installers have mistakingly used the incorrect lubricant and had to order another seal.	
CF790025	Centrocerin lubricant. Water soluble lubricant designed to ease assembly of flue components. Other lubricants are not suitable as they will damage the flue.  Please note: This comes with the horizontal and vertical flue kits.	

# Rinnai INFINITY N56kWi common flueing polypropylene flue kits and components

<b>Starter kits</b> , one starter kit is required for each application		
Code	Description	Image
CFKRS110	Room air starter kit 110 mm. Contains; room air vent, condensate trap, and centrocerin lubricant.	1
CFKOS110	Outside air starter kit 110 mm. Contains; room air vent, end cap, condensate trap, and centrocerin lubricant.	2
<b>Header connection kits</b>		
<ul style="list-style-type: none"> <li>• inline, one kit for each water heater</li> <li>• back-to-back, one kit for every two water heaters</li> </ul>		
CFKRCS110	Room air inline connection kit. Contains; collector Ø110 mm 1-branch, 90° bend, extension 500 mm, room air adapter.	3
CFKRCS110	Room air back-to-back connection kit. Contains; collector Ø110 mm 2-branch, 90° bend (x2), extension 500 mm (x2), room air adapter (x2).	4
CFKOCS110	Outside air inline connection kit. Contains; collector Ø110 mm 1-branch (x2), 90° bend, extension 500 mm, outside air adapter and rubber flex.	5
CFKOCS110	Outside air back-to-back connection kit. Contains; collector Ø110 mm 2-branch (x2), 90° bend (x2), extension 500 mm (x2), room air adapter (x2)	6
<b>Horizontal termination kits</b>		
CFKRWT110	Room air Ø110 mm horizontal termination kit	7
CFKOWT110	Outside air Ø110 mm horizontal termination kit	8
CFKRWT160	Room air Ø160 mm horizontal termination kit, includes flue adapter	9
CFKOWT160	Outside air Ø160 mm horizontal termination kit, includes flue adapters	10
<b>Vertical termination kits</b>		
CFKRVT160	Room air Ø160 mm vertical termination kit. Contains; vertical terminal, stainless UV sleeve, exhaust rain cap, Ø110-160 mm adapter.	11
CFKOVT160	Outside air Ø160 mm vertical termination kit. Contains; vertical terminal (x2), stainless UV sleeve (x2), exhaust rain cap, intake rain cap, Ø110-160 mm adapter.	12
<b>Common parts</b>		
CF790028	Flue pipe Ø110 mm	13
CF790089	Flue pipe Ø160 mm	13
CF790026	45 ° bends Ø110 mm	14
CF790086	45 ° bends Ø160 mm	14
CF790087	90 ° bend Ø160 mm	15
CF790091	Flue support Ø110 mm	16
CF790092	Flue support Ø160 mm	16

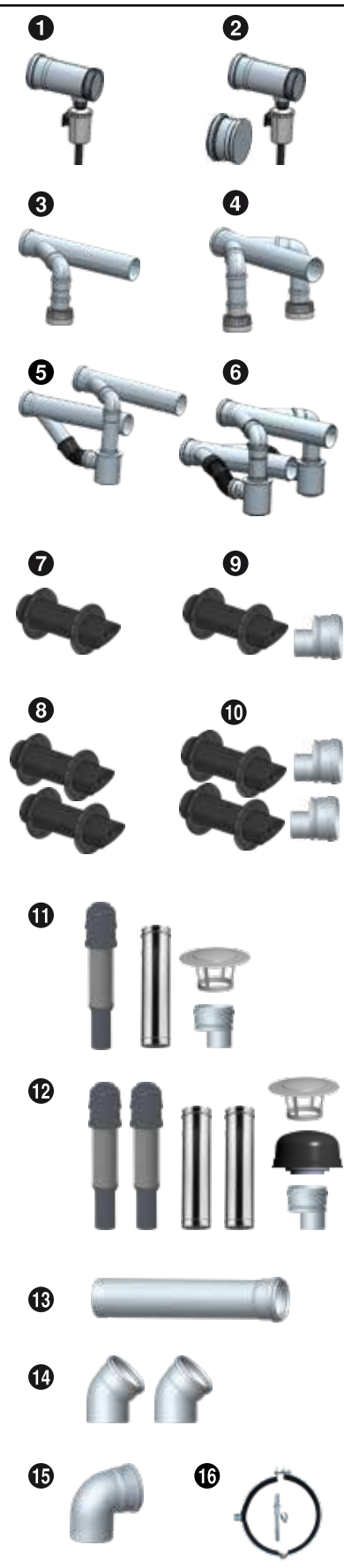

---

# Rinnai INFINITY

accessory product pages

---





# Digital controllers



With a Rinnai INFINITY controller you choose your own personalised settings. Just select the water temperature you want between 37-55 °C in up to four different locations.

## Why have controllers?



- Safety feature for young children, control the temperature coming out of the hot water tap.
- Reduce temperature fluctuations when other taps are used in the house.
- An extra two year warranty on your Rinnai INFINITY when controllers are installed.
- Use as a troubleshooting diagnostic tool, error codes will display when there is a problem with the INFINITY.

## Residential controller configurations

A maximum of four (three for the HD49kWi / A28i indoor models, and N-Series) can be fitted, with the following provisos:

- Only one Kitchen Deluxe controller—only installed if a Bathroom Deluxe controller is installed
- Maximum of two Bathroom Deluxe controllers
- Only one controller can be set to deliver 55 °C, this cannot be a controller in a bathroom

Each controller can be individually programmed, but the water heater can only deliver one set temperature at any time. For example, John is in the shower and has set the controller to 42 °C. Megan can only change the programmed temperature at the kitchen once John is out of the shower.

	Compact controller	Bathroom Deluxe controller	Kitchen Deluxe controller
			
<b>Code</b>	MC601A	BC100V1Z	MC100V1Z
<b>Colour</b>	Off-white	Silver	Silver
<b>Dimensions</b>	H - 120 mm W - 90 mm D - 20 mm	H - 97 mm W - 195 mm D - 20 mm	H - 120 mm W - 128 mm D - 20 mm
<b>Suitable for</b>	Anywhere in the house	Bathrooms <sup>1</sup>	Kitchens and laundries <sup>2</sup>
<b>Cable</b>	Comes with 10 m of cable	Comes with 10 m of cable	Comes with 10 m of cable
<b>Additional cable</b>	Additional 10 m cable R1069	Additional 10 m cable R1069	Additional 10 m cable R1369

<sup>1</sup> Set the desired temperature and water level and walk away. A voice message will let you know when your bath is ready. If you have other deluxe controllers around the house the message will play on all of them.

<sup>2</sup> The Kitchen Deluxe controller is designed to be used in conjunction with the Bathroom Deluxe controllers.



## Water temperature control

Only the Kitchen Deluxe controller can be designated as the master water controller, as the name suggests, the location for this is in the kitchen. All the remaining controllers are designated sub-controllers and are for use in bathrooms, toilets, and laundries. The maximum temperature for sub-controllers is 50 °C, to minimise the risk of burns.

Any controller that has priority is capable of setting the water temperature to be delivered. Priority can only be given to one controller at a time, and changing priority can only be done when all hot water taps have been closed.

Available controller temperatures are:

Controller	Temperature °C
Kitchen	37, 38, 39, 40, 41, 42, 43, 44, 45, 46, 48, 50, 55, 60*, 65*, 75*
Bathroom (hot water)	37, 38, 39, 40, 41, 42, 43, 44, 45, 46, 48, 50
Bathroom (bath fill)	37, 38, 39, 40, 41, 42, 43, 44, 45, 46, 47, 48

\* Some Rinnai water heaters can be programmed to deliver higher temperatures from the master water controllers, i.e. in commercial applications

To obtain water temperatures lower than 37 °C, open the cold water tap and add cold water until the desired lower temperature is reached.

## Controllers are not suitable for all installations

Some limitations and exclusions to be aware of:

- If an EZ Connect cable is used, the bath fill function on the Bathroom Deluxe controller won't work
- Controllers cannot be used with Rinnai INFINITY units connected to a solar system as they are not compatible with the higher temperatures coming from the INFINITY (dip switch change from 55 to 75 °C).
- Controllers are not suitable for ring main applications using N-Series models

## Water controller cables

Water controllers operate at extra low voltage (12 V DC), which is supplied from the water heater.

Controllers come with 10 m of electrical cable. The appliance end of the controller cables are fitted with spade terminals.



Extension cabling is available as an accessory from Rinnai. Alternatively, a two core sheathed (double insulated) flex with a minimum cross sectional area of 0.5 mm<sup>2</sup> may be used.

Maximum individual cable runs:

- One controller = 100 m
- Two controllers = 50 m (per controller)
- Three plus controllers = 20 m (per controller)

Water controller cables are not polarity sensitive.

# Metal recess box



A recess box enables an external continuous flow water heater to be partially or fully recessed into an external wall, covered, and out of sight.

## Positioning

A Rinnai INFINITY unit positioned inside a recess box operates at a slightly louder level than a Rinnai INFINITY installed on an outside wall. Please keep this in mind if positioning near a bedroom as the operating noise could affect some people.

## Building code compliance

Local councils may have their own requirements regarding a recess box installation, as it is similar in detail to installing a meter box. If in doubt over compliance, it is advisable to consult the local council prior to installation.

## Suitability

- Outdoor installations only
- New construction or major renovation—installation needs to commence during the framing stage and before internal linings, cladding, or building wrap is applied

<b>Code</b>	R1405	R1407
<b>Construction</b>	Folded galvanised steel, powder coated white—can be painted to match the exterior cladding.	
<b>Colour</b>	White	White
<b>Dimensions</b>	H - 945 mm W - 417 mm D - 205 mm	H - 945 mm W - 514 mm D - 270 mm
<b>Suitable for - current</b>	Current A-Series units (A16, A20, A24, A26)	Current HD49kWe, HD250, and EF26
<b>Suitable for - discontinued</b>	Discontinued VT range (VT16, VT20, VT24, VT26)	Discontinued HD200, and EF24



There is no recess box for our N56kWe due to the significant size of the unit.

# Pipe covers



If you want a clean smooth finish to the installation, the Rinnai INFINITY pipe cover can be used to cover pipes, valves, and even the external power point. The pipe cover kits vary in size and colour depending on the model.

The pipe cover kits are sold as a flat pack and require assembly. With our current range of water heaters assembly can be done by the homeowner—this is because assembly does not require taking the cover off the water heater.

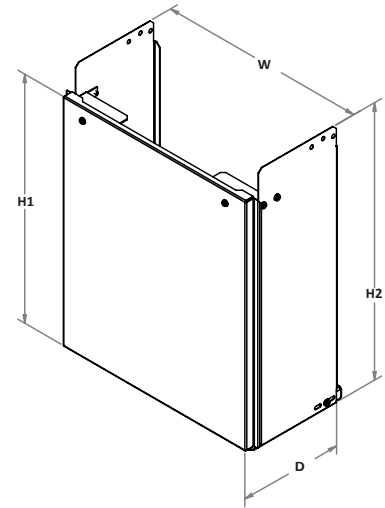

	<b>A-Series external pipe cover</b>	<b>EF26 pipe cover</b>	<b>HD250 pipe cover</b>	<b>HD49 pipe cover</b>	<b>N56 pipe cover</b>
<b>Code</b>	R1385	R1416	R1402SC	R1417	R1415
<b>Colour</b>	White	White	Silver	Silver	Gunmetal grey
<b>Suitable for</b>	A16, A20, A24, A26	EF26	REU-VR3237-WG	HD49kWi and HD49kWe	N56kWi and N56kWe
<b>Dimensions</b>	H1 394 mm W 334 mm D 167 mm H2 438 mm	H1 450 mm W 350 mm D 186 mm H2 428 mm	H1 394 mm W 453 mm D 230 mm H2 428 mm	H1 450 mm W 355 mm D 218 mm H2 485 mm	H1 450 mm W 465 mm D 243-254 mm H2 465 mm

**Note**

H1 is the height of the panel in the front, H2 is the height of the panel in the back, refer line drawing above.

# Rinnai INFINITY flue diverters



*A-Series sideways diverter pictured above*

**A-Series side diverter**



**EF26 side diverter**



**Upwards diverter**



Rinnai stainless steel flue diverters are an accessory that can be fitted to an external Rinnai INFINITY water heater to expel combustion gases in either a sideways or upwards direction. The flue diverter is fitted with screws to the flue terminal of the water heater<sup>1</sup>.

## **Suitability**

- Externally mounted Rinnai INFINITY continuous flow water heaters NOT installed in a recess box.
- Balconies, patios or other enclosed areas where products of combustion can be rapidly dispersed into the open-air.
- **Sideways flue diverter only**—external single water heater applications, can be installed for left or right handed installations.

## **Specific applications**

Noise reduction, where the unit is positioned close to a neighbouring property.

Where there may be an obstruction such as a tree, fence, wall or other structure, that even though the Rinnai INFINITY is installed with the required clearances, will perform more efficiently if the flue gases are expelled away from the obstruction.

**Important**

<sup>1</sup> The flue diverter **MUST** remain as a permanent fixture as removal could mean the water heater position no longer complies with AS/NZS 5601.1, translation, once a flue diverter is fitted it **MUST NOT** be removed.

# Sideways flue diverters

Where clearance to an openable window or other building structure is tight, the clearance shifts to the point of discharge, close to the edge of the water heater case.

## Codes

FDS16	A16
FDS20	A20
FDS24	A24 and A26
FDS26E	EF26

There are no sideways diverters for the N49kWe or N56kWe.

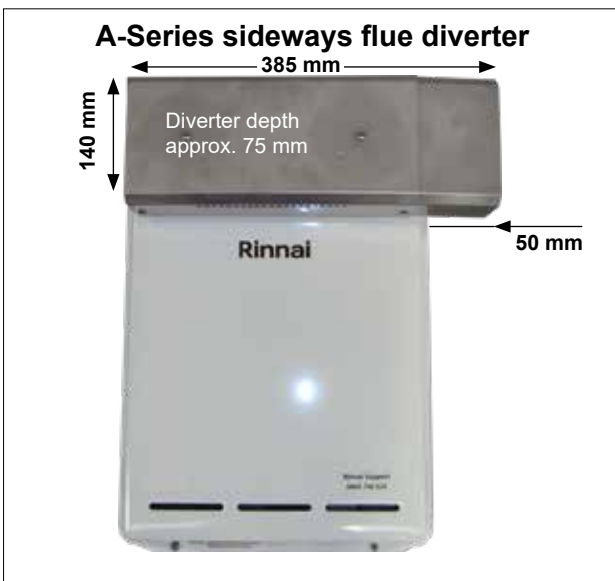
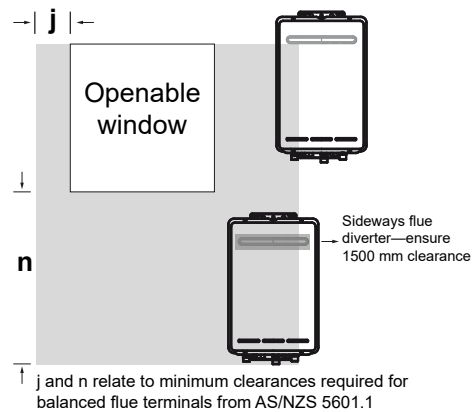

# Upwards flue diverters

## Specific commercial application

Where there are multiple units installed that are positioned facing each other there is the potential for the units to suffocate from the flue gases directly opposite. With an upwards flue diverter the flue gases can be expelled upwards and away from the units.

## Codes

FDU16	A16
FDU20	A20
FDU24	A24 and A26
FDU32	HD250

There are no upwards diverters for the N49kWe or N56kWe.



# N56kWi internal flue diverter kit



The N56kWi internal flue diverter is a flue accessory kit that allows you to move the flue terminal position up and away from the air intake by up to 1.5m.

It is designed for when a traditional horizontal terminal cannot be installed due to the flue being a nuisance or due to flue restrictions. It works in conjunction with the horizontal flue terminal (part FFP100HKIT).

Flue diverter kit includes:

- 90 ° elbows (x2)
- connecting flue pipe 1000 mm
- flue extension 695 mm
- wall brackets (x3)



<b>Code</b>	FFP100DIV
<b>Construction</b>	The N56kWi (internal) flue diverter is manufactured from black UV resistant PVC. It has been tested and can ONLY BE used with the Rinnai INFINITY N56kWi water heater.
<b>Installation</b>	If you don't need to extend the full 1.5 m, you can just use the connecting pipe.



# Security bracket



A sturdy security bracket can be installed to act as a deterrent to thieves. Consisting of two U-shaped 2 mm powder coated galvanised steel plates, which interlock through the lower bracket of the Rinnai INFINITY. The bracket is secured with a padlock (not included).

Ideal for builders who need to protect the Rinnai INFINITY before the home is sold or handed over to the new owners.



Colour is off-white—can be painted.

<b>Code</b>	ACC1395
<b>Suitable for</b>	All Rinnai INFINITY continuous flow gas water heaters—can be retrofitted to existing installations. Can be installed on all cladding systems, like weatherboard, brick, and plaster. Can also be installed inside a recess box.
<b>Dimensions</b>	<ul style="list-style-type: none"><li>• Height - 70 mm</li><li>• Width - 190 mm</li><li>• Depth - 33.5 mm</li></ul>
<b>How it works</b>	The bracket prevents access to the bolts fixing the unit to the wall, this locks the lower section of the INFINITY in place, and prevents the unit from being quickly removed from the wall.

# Commercial error switch

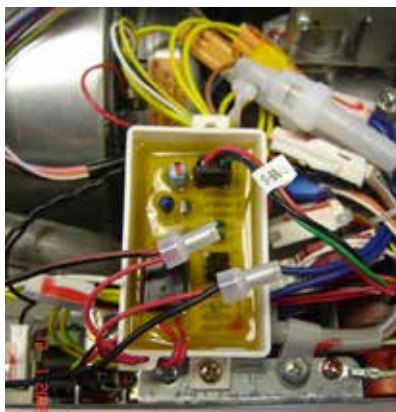

The Rinnai INFINITY error indication switch is a volt-free, normally open switch. The switch will shift to a closed position when there is an active error in the water heater.

The switch is intended to be connected to a monitoring system such as a building management system, or audible error indication system.

System designers should note that some errors will reset an inactive (open) state under particular conditions. It is important that this is clearly understood when developing monitoring and response systems.

<b>Code</b>	<ul style="list-style-type: none"> <li>• R1070 (HD49kWe, HD49kWi, HD250)</li> <li>• REUOPU3 (N56kWe and N56kWi)</li> </ul>
<b>Suitable for</b>	Suitable for commercial applications with the HD49kWe, HD49kWi, HD250, N56kWi, and N56kWe.
<b>Load switching</b>	<p>Will switch the following maximum loads. Systems requiring loads greater than this should be configured via an external relay.</p> <ul style="list-style-type: none"> <li>• Voltage (AC or DC) → 24 Volts</li> <li>• Current → 1 Amp</li> </ul>

# HD EZ connect cable



The EZ connect cable allows two Rinnai INFINITY HD water heaters to be connected so they can function as one large unit.

The water heaters can be installed 5-460 mm apart. The maximum distance of 460 mm is so the cable will reach between the units, and to prevent temperature fluctuations when the water is turned on and off.

Installation by a certified tradesperson is required.

<b>Code</b>	REUEZC
<b>Cable length</b>	1850 mm
<b>Suitable for</b>	Suitable for the all HD Rinnai INFINITY water heaters <sup>1</sup> .
	<p><b>Please note</b> The bath fill function on the Bathroom Deluxe controller will not work if an EZ connect cable is fitted.</p> <p><sup>1</sup> The A28i can also use the EZ connect cable for connecting two water heaters in a residential application.</p>

## N-Series cascade cable 3 m



With the use of the cascade cable, up to 24 N-Series water heaters can be electronically connected.

This connection will rotate the water heater operation order to ensure equal usage of each appliance and enable all water heaters connected to modulate operation and function as one hot water source.

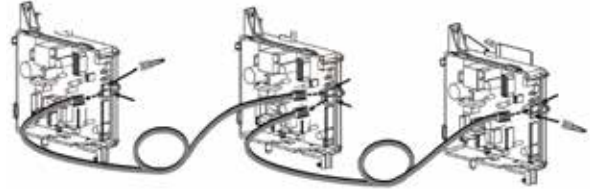

---

**Code**

REUCSAC1

---

**Suitable for**

Suitable for the N-Series N56kWe and N56kWi water heaters. One cable is required for each water heater.

Cable kit includes:

- One cable
- Two cascade jumpers
- Two cable ties and two cable tie clamps

---

## N-Series pump cable 2m



The N-Series water heaters have the ability to control a circulation pump (commercial ring main application) with the use of a pump cable connector. This allows hot water to cycle through the ring main, ensuring hot water is quickly available when a tap is opened.

Cable is UV resistant and rated for outdoor installation.

---

**Code**

R1071

---

**Suitable for**

- Single unit N56 commercial installation
- Commercial / showerblock installations with multiple N56 units as specified by Rinnai commercial

**Please note:**

Rinnai INFINITY digital controllers are not compatible with the N-Series pump cable and ring main applications.

# INFINITY HD manifolding

Rinnai INFINITY HD units can be manifolded together, in banks of five (up to 25 units), by connecting them together in parallel to enable a greater hot water flow rate than is possible with a single unit.

A manifold electronic control system (MECS) links each HD unit in the system, and will turn on each unit as required. The system is designed to ensure gas is not wasted and that an endless supply of hot water is always available.

## How it works

A master, located internally or externally, and sub-communication PCB is installed in the first unit, other units have a sub-communication slave cable installed. The master communication PCB receives information about flow rates from each unit and balances the load on each unit.

Random selection of the units required to supply the demand means all units share the workload evenly.

All information is transmitted via communication cables to the slave units. The master control also has an inbuilt fault detection system and will allocate a replacement should one unit fail.

## Suitability

- HD49kWe ext. REU-VCM2837WC-ZK
- HD49kWi int. REU-VCM2837FFC-ZK
- HD250 ext. REU-VR3237WG-ZK(S)

## Codes

- REUMSBM internal master manifold kit for a connection made inside the unit
- REUMSBMB external master manifold kit for a connection made outside the unit
- REUMSBC1 manifold slave cable
- REUMSBC2 joiner for greater than five manifolded HD units

MECS	Master PCB		Slave	Joiner
Position	INSIDE the INFINITY	OR OUTSIDE the INFINITY	REUMSBC1	REUMSBC2
Code	REUMSBM	REUMSBMB		
Number of water heaters				
2	1	1	-	-
3	1	1	1	-
4	1	1	2	-
5	1	1	3	-
6	2	2	2	1
7	2	2	3	1
8	2	2	4	1
9	2	2	5	1
10	2	2	6	2
11	3	3	5	2
12	3	3	6	2
13	3	3	7	2
14	3	3	8	2
15	3	3	9	2
16	4	4	8	3
17	4	4	9	3
18	4	4	10	3
19	4	4	11	3
20	4	4	12	3
21	5	5	11	4
22	5	5	12	4
23	5	5	13	4
24	5	5	14	4
25	5	5	15	4

---

# Appendices

---



# Appendix 1

## water flow and gas usage

When determining the Rinnai INFINITY model it's important to know what the incoming water temperature will be—this is calculated using the worst case scenario (winter). This temperature is needed to work out the temperature rise to produce the hot water needed.

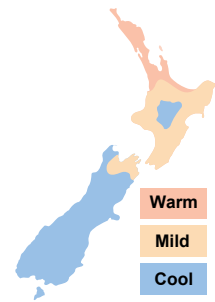

### Approximate incoming water temperatures in winter

- Northland and Auckland use 15 °C
- BOP, Gisborne, and Hawkes Bay use 10 °C
- Waikato, and South Island (excl. Nelson & Marlborough) use 5 °C

### Degree temperature rise

In the specification pages for the Rinnai INFINITY models we express a parameter called 'nominal water capacity'. This means at a 25° rise, the unit will produce a certain number of litres per minute of hot water.

For example:

- The A26 external will produce 26 litres per minute at a 25° rise
- The A24 external will produce 24 litres per minute at a 25° rise

Using the above example, for incoming water at 10 °C and a required temperature of 55 °C, the A26 external will produce 14.4 litres per minute at a 45 ° rise (55-10), and the A24 external will produce 13.3 litres per minute at a 45 ° rise.



## Water flow and gas usage table Rinnai INFINITY A-Series and EF26 temperature preset to 55 °C

Model	Approx. min. to max. gas input (MJ/h)	5 ° temperature rise				10 ° temperature rise			
		L/min	L/h	Pressure loss through unit (kPa)	Approx. gas consumption (MJ/h)	L/min	L/h	Pressure loss through unit (kPa)	Approx. gas consumption (MJ/h)
A16	16.3-124	20.0	1200	100	31.0	20.0	1200	100	62.0
A20	19.9-156	24.0	1440	140	37.2	24.0	1440	140	74.4
A24	16.3-184	26.0	1560	180	40.3	26.0	1560	180	80.6
A26	16.3-199	26.0	1560	180	40.3	26.0	1560	180	80.6
EF26	16.3-175	26.0	1560	210	35.7	26.0	1560	210	71.4
A28i	11-210	28.6	1716	150	43.8	28.6	1716	150	87.6
		15 ° temperature rise				20 ° temperature rise			
A16	16.3-124	20.0	1200	100	93.0	20.0	1200	100	124.0
A20	19.9-156	24.0	1440	140	111.6	24.0	1440	140	148.8
A24	16.3-184	26.0	1560	180	120.9	26.0	1560	180	161.2
A26	16.3-199	26.0	1560	180	120.9	26.0	1560	180	161.2
EF26	16.3-175	26.0	1560	210	107.1	26.0	1560	210	142.7
A28i	11-210	28.6	1716	150	131.4	28.6	1716	150	175.2
		25 ° temperature rise				30 ° temperature rise			
A16	16.3-124	16.0	960	60	124.0	13.3	800	45	124.0
A20	19.9-156	20.0	1200	100	156.0	16.7	1000	70	156.0
A24	16.3-184	24.0	1440	145	184.0	20.0	1200	100	184.0
A26	16.3-199	26.0	1560	180	199.0	21.7	1300	110	199.0
EF26	16.3-175	26.0	1560	210	175.0	21.7	1300	150	175.0
A28i	11-210	28.0	1680	150	210.0	23.3	1400	120	210.0
		35 ° temperature rise				40 ° temperature rise			
A16	16.3-124	11.4	686	30	124.0	10.0	600	25	124.0
A20	19.9-156	14.3	857	45	156.0	12.5	750	42	156.0
A24	16.3-184	17.1	1029	70	184.0	15.0	900	45	184.0
A26	16.3-199	18.6	1114	90	199.0	16.3	975	70	199.0
EF26	16.3-175	18.6	1114	100	175.0	16.3	975	90	175.0
A28i	11-210	20.0	1200	80	210.0	17.5	1050	70	210.0
		45 ° temperature rise				50 ° temperature rise			
A16	16.3-124	8.9	533	20	124.0	8.0	480	18	124.0
A20	19.9-156	11.1	667	35	156.0	10.0	600	30	156.0
A24	16.3-184	13.3	800	45	184.0	12.0	720	40	184.0
A26	16.3-199	14.4	867	50	199.0	13.0	780	45	199.0
EF26	16.3-175	14.4	867	70	175.0	13.0	780	60	175.0
A28i	11-210	15.6	933	50	210	14.0	840	40	210.0

## Water flow and gas usage table Rinnai INFINITY HD models temperature preset to 55 °C

Model	Approx. min. to max. gas input (MJ/h)	5 ° temperature rise				10 ° temperature rise			
		L/min	L/h	Pressure loss through unit (kPa)	Approx. gas consumption (MJ/h)	L/min	L/h	Pressure loss through unit (kPa)	Approx. gas consumption (MJ/h)
HD49kWe	11-210	28.6	1716	150	43.8	28.6	1716	150	87.6
HD49kWi	11-210	28.6	1716	150	43.8	28.6	1716	150	87.6
HD250	20-250	37.0	2220	200	55.3	37.0	2220	200	110.6
		15 ° temperature rise				20 ° temperature rise			
HD49kWe	11-210	28.6	1716	150	131.4	28.6	1716	150	175.2
HD49kWi	11-210	28.6	1716	150	131.4	28.6	1716	150	175.2
HD250	20-250	37.0	2220	200	165.9	37.0	2220	200	250.0
		25 ° temperature rise				30 ° temperature rise			
HD49kWe	11-210	28.0	1680	150	210.0	23.3	1400	120	210.0
HD49kWi	11-210	28.0	1680	150	210.0	23.3	1400	120	210.0
HD250	20-250	32.0	1920	140	250.0	26.7	1602	100	250.0
		35 ° temperature rise				40 ° temperature rise			
HD49kWe	11-210	20.0	1200	80	210.0	17.5	1050	70	210.0
HD49kWi	11-210	20.0	1200	80	210.0	17.5	1050	70	210.0
HD250	20-250	22.9	1374	60	250.0	20	1200	50	250.0
		45 ° temperature rise				50 ° temperature rise			
HD49kWe	11-210	15.6	933	50	210.0	14.0	840	40	210.0
HD49kWi	11-210	15.6	933	50	210.0	14.0	840	40	210.0
HD250	20-250	17.8	1068	40	250.0	16	960	40	250.0

## Water flow and gas usage table Rinnai INFINITY HD models temperature preset to 75 °C

Model	Approx. min. to max. gas input (MJ/h)	5 ° temperature rise			10 ° temperature rise				
		L/min	L/h	Pressure loss through unit (kPa)	Approx. gas consumption (MJ/h)	L/min	L/h	Pressure loss through unit (kPa)	Approx. gas consumption (MJ/h)
HD49kWe	11-210	25.0	1500	150	38.3	25.0	1500	150	76.6
HD49kWi	11-210	25.0	1500	150	38.3	25.0	1500	150	76.6
HD250	20-250	24.0	1440	200	36.4	24.0	1440	200	72.9
		15 ° temperature rise			20 ° temperature rise				
HD49kWe	11-210	25.0	1500	150	114.9	25.0	1500	150	153.1
HD49kWi	11-210	25.0	1500	150	114.9	25.0	1500	150	153.1
HD250	20-250	24.0	1440	200	109.3	24.0	1440	200	145.7
		25 ° temperature rise			30 ° temperature rise				
HD49kWe	11-210	25.0	1500	150	191.4	23.3	1400	130	210.0
HD49kWi	11-210	25.0	1500	150	191.4	23.3	1400	130	210.0
HD250	20-250	24.0	1440	200	182.2	24.0	1440	140	250.0
		35 ° temperature rise			40 ° temperature rise				
HD49kWe	11-210	20.0	1200	90	210.0	17.5	1050	75	210.0
HD49kWi	11-210	20.0	1200	90	210.0	17.5	1050	75	210.0
HD250	20-250	22.9	1371	130	250.0	20.0	1200	100	250.0
		45 ° temperature rise			50 ° temperature rise				
HD49kWe	11-210	15.6	933	60	210.0	14.0	840	50	210.0
HD49kWi	11-210	15.6	933	60	210.0	14.0	840	50	210.0
HD250	20-250	17.8	1067	80	250.0	16.0	960	70	250.0
		55 ° temperature rise			60 ° temperature rise				
HD49kWe	11-210	12.7	764	40	210.0	11.7	700	35	210.0
HD49kWi	11-210	12.7	764	40	210.0	11.7	700	35	210.0
HD250	20-250	14.5	873	50	250.0	13.3	800	45	250.0
		65 ° temperature rise			70 ° temperature rise				
HD49kWe	11-210	10.8	646	30	210.0	10.0	600	28	210.0
HD49kWi	11-210	10.8	646	30	210.0	10.0	600	28	210.0
HD250	20-250	12.3	738	40	250.0	11.4	686	35	250.0
		75 ° temperature rise			80 ° temperature rise				
HD250	20-250	10.7	640	30	250.0	10.0	600	25	250.0

## Water flow and gas usage table Rinnai INFINITY N-Series temperature preset to 55 °C

Model	Approx. min. to max. gas input (MJ/h)	5 ° temperature rise				10 ° temperature rise			
		L/min	L/h	Pressure loss through unit (kPa)	Approx. gas consumption (MJ/h)	L/min	L/h	Pressure loss through unit (kPa)	Approx. gas consumption (MJ/h)
N56kWi	16-209	37.0	2220	300	48	37.0	2220	300	96
N56kWe	16-209	37.0	2220	300	48	37.0	2220	300	96
		15 ° temperature rise				20 ° temperature rise			
N56kWi	16-209	37.0	2220	300	144	37.0	2220	300	192
N56kWe	16-209	37.0	2220	300	144	37.0	2220	300	192
		25 ° temperature rise				30 ° temperature rise			
N56kWi	16-209	32.0	1920	300	209	26.7	1600	300	209
N56kWe	16-209	32.0	1920	300	209	26.7	1600	300	209
		35 ° temperature rise				40 ° temperature rise			
N56kWi	16-209	22.9	1371	270	209	20.0	1200	170	209
N56kWe	16-209	22.9	1371	270	209	20.0	1200	170	209
		45 ° temperature rise				50 ° temperature rise			
N56kWi	16-209	17.8	1067	140	209	16.0	960	110	209
N56kWe	16-209	17.8	1067	140	209	16.0	960	110	209

### Approximate gas consumption

Thermal efficiency calculation based on 97% from star rating test.

### Pressure loss through unit

- Temperature rise 5-25 °C assumes set temperature of 37 °C → bypass fully open
- Temperature rise 30-50 °C assumes set temperature of 55 °C → bypass fully closed, actual pressure loss will be lower

## Water flow and gas usage table Rinnai INFINITY N-Series temperature preset to 75 °C

Model	Approx. min. to max. gas input (MJ/h)	5 ° temperature rise			10 ° temperature rise				
		L/min	L/h	Pressure loss through unit (kPa)	Approx. gas consumption (MJ/h)	L/min	L/h	Pressure loss through unit (kPa)	Approx. gas consumption (MJ/h)
N56kWi	16-209	23.0	1380	300	30	23.0	1380	300	60
N56kWe	16-209	23.0	1380	300	30	23.0	1380	300	60
		15 ° temperature rise			20 ° temperature rise				
N56kWi	16-209	23.0	1380	300	89	23.0	1380	300	119
N56kWe	16-209	23.0	1380	300	89	23.0	1380	300	119
		25 ° temperature rise			30 ° temperature rise				
N56kWi	16-209	23.0	1380	300	149	23.0	1380	300	179
N56kWe	16-209	23.0	1380	300	149	23.0	1380	300	179
		35 ° temperature rise			40 ° temperature rise				
N56kWi	16-209	22.9	1371	270	209	20.0	1200	170	209
N56kWe	16-209	22.9	1371	270	209	20.0	1200	170	209
		45 ° temperature rise			50 ° temperature rise				
N56kWi	16-209	17.8	1067	140	209	16.0	960	110	209
N56kWe	16-209	17.8	1067	140	209	16.0	960	110	209
		55 ° temperature rise			60 ° temperature rise				
N56kWi	16-209	14.5	873	90	209	13.3	800	80	209
N56kWe	16-209	14.5	873	90	209	13.3	800	80	209
		65 ° temperature rise			70 ° temperature rise				
N56kWi	16-209	12.3	738	65	209	11.4	686	55	209
N56kWe	16-209	12.3	738	65	209	11.4	686	55	209
		75 ° temperature rise			80 ° temperature rise				
N56kWi	16-209	10.7	640	50	209	10.0	600	45	209
N56kWe	16-209	10.7	640	50	209	10.0	600	45	209

## Commercial unit water pressure and flow rate graphs

Rinnai commercial INFINITY water heaters have a water flow pathway which bypasses the main heat exchanger. The flow through the bypass is electronically controlled by an actuator/water flow valve.

At lower set temperatures, generally 55 °C or less, the bypass will often be in the fully open position which reduces the overall pressure loss through the water heater. At higher set temperatures, generally 75 °C or higher, the bypass is fully closed. All water flow passes through the heat exchanger which increases the pressure loss through the appliance at any given flow rate when compared to lower set temperatures.

When sizing pumps for Demand Duo-type systems, the bypass fully closed pressure losses should be used as the Rinnai INFINITY units in these systems are commonly set to 75 °C.

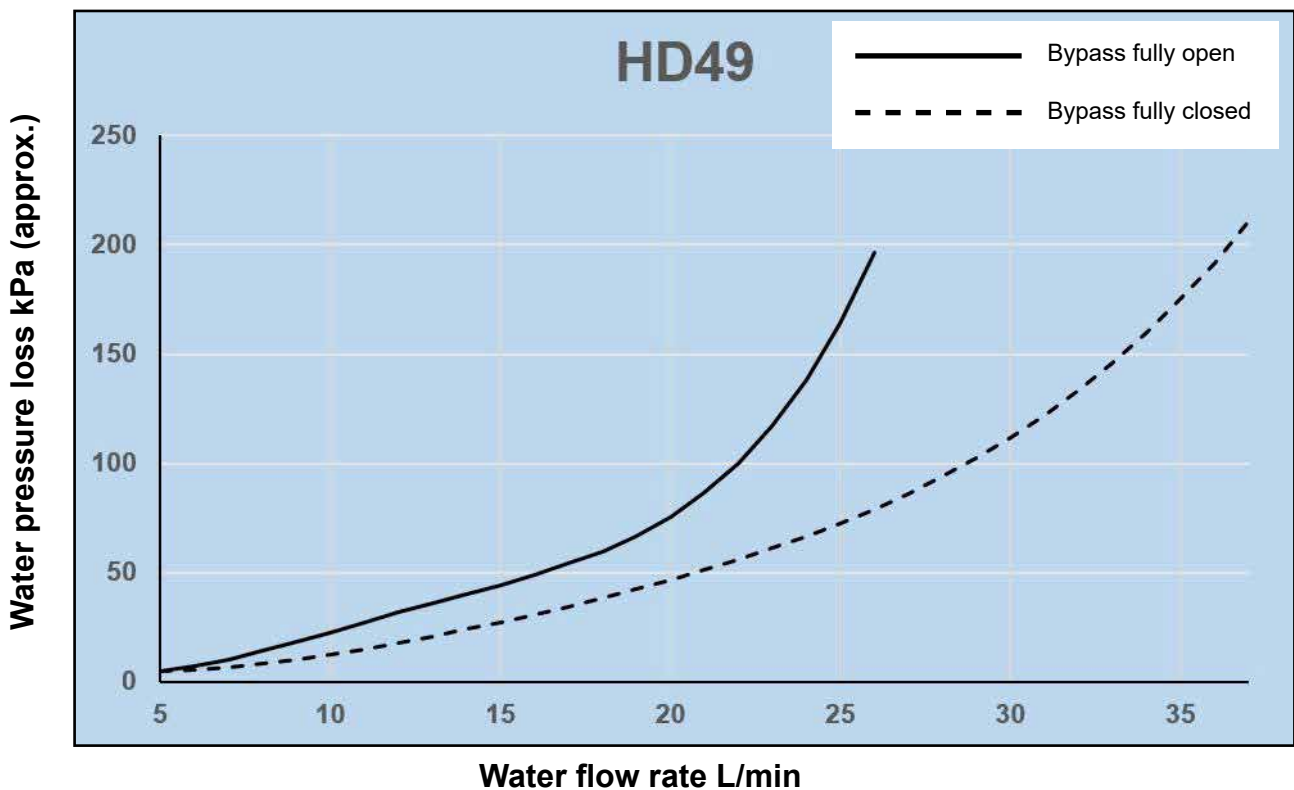



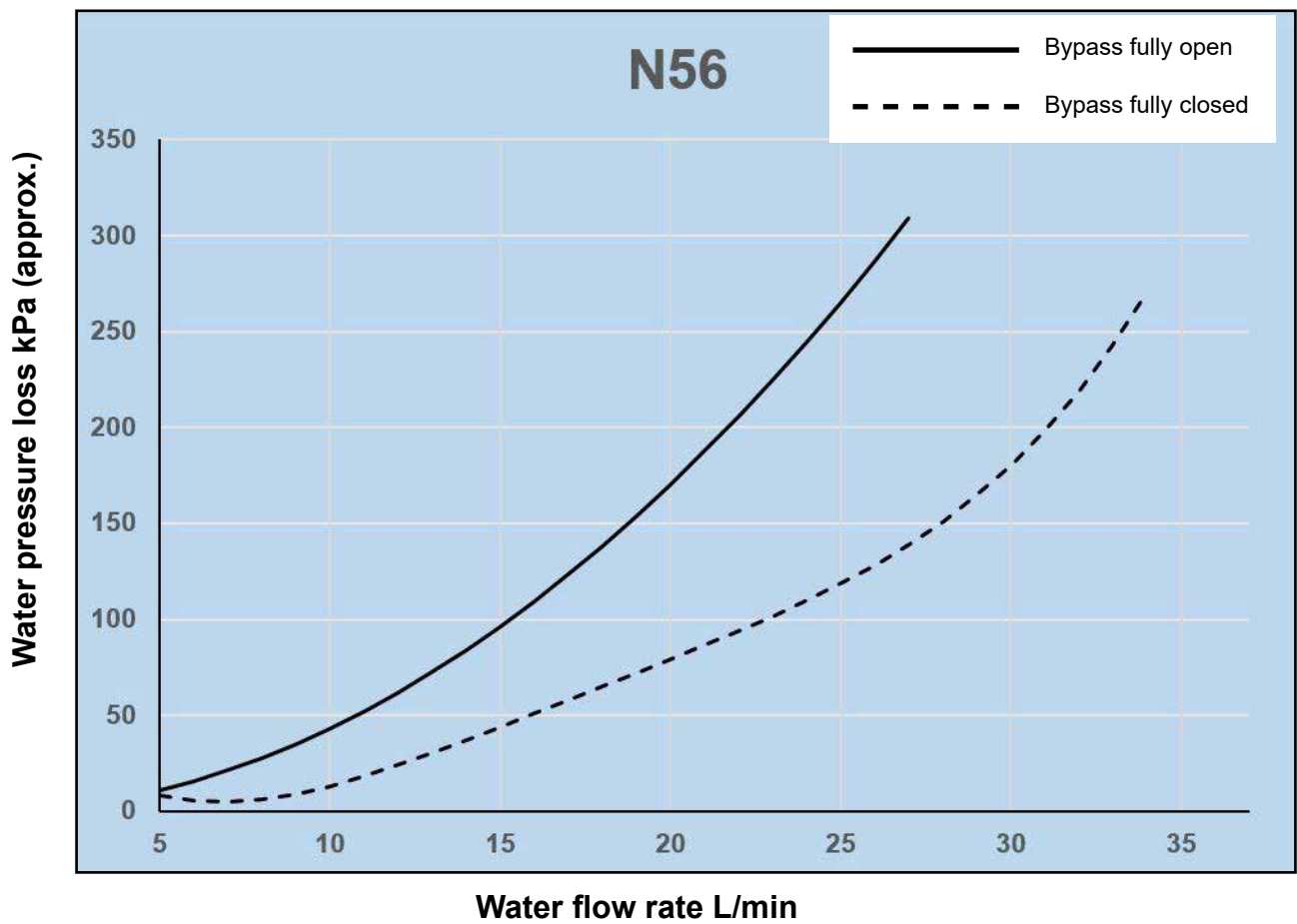
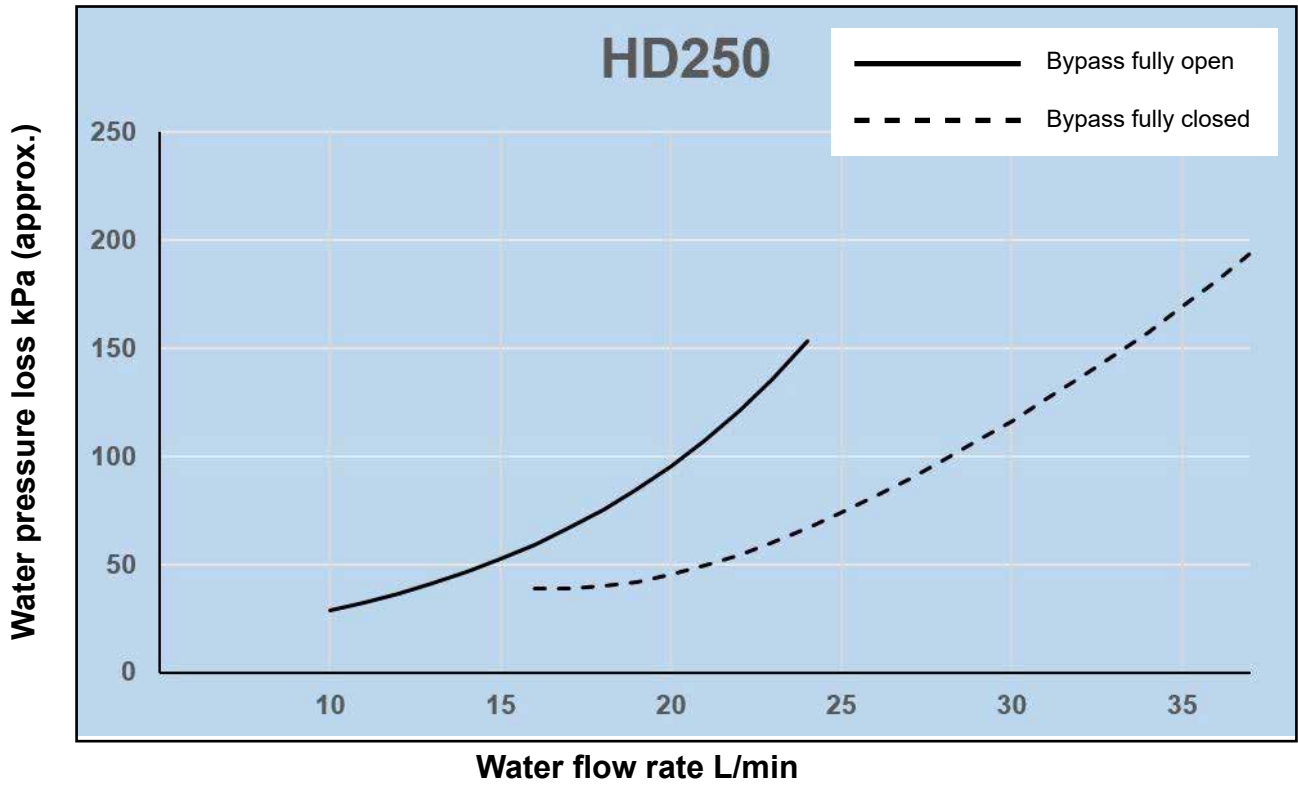

## Appendix 2

### Rinnai INFINITY inbuilt frost protection

Frost protection is fitted as standard on all Rinnai INFINITY models. Frost protection operates automatically, as required, whenever the appliance is connected to power.

#### How frost protection works

When the temperature inside the unit drops below 3.5 °C the frost protection turns on, providing heat via electricity. Once the temperature inside the unit reaches 7 °C the frost protection switches itself off.



The heat, provided by strategically placed ceramic heating elements, stops the water from freezing within the pipework of the unit.

As frost protection requires electricity, it is important that the unit is connected to the power supply at all times. If left off in an area prone to frost Rinnai recommend draining the appliance to prevent frost damage (not covered by warranty).

# Appendix 3

## gas boosted solar

Rinnai INFINITY HD and A28i models<sup>1</sup> can be easily plumbed to provide additional heat to a solar hot water system to heat water when solar hot water is not available.

### How a gas boosted system works

1. The sun's rays heat water in the solar panels.
2. Hot water from the panels is stored in the cylinder.
3. If the water is too cold, the Rinnai INFINITY gas boost heats the water on demand as it travels from the cylinder to the tap.

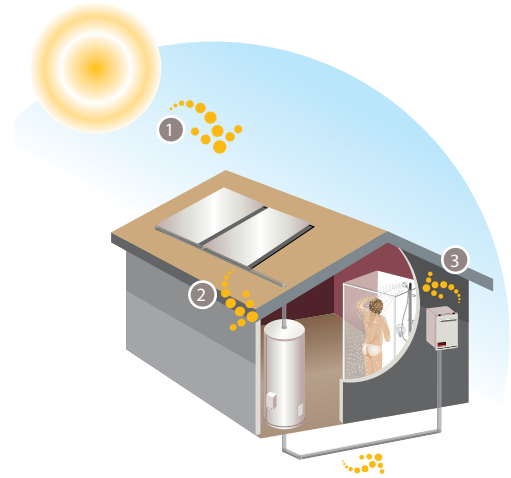

The size of the Rinnai INFINITY depends on the number of bathrooms, select the Rinnai INFINITY model as if solar hot water was not available.

<sup>1</sup> N-Series models are also suitable for solar installations, but are not as economical as HD models—there is no gain by having a condensing water heater, as in a solar application, the water is already pre-heated.

### Recommended system layout using a Rinnai INFINITY and flow diversion valve

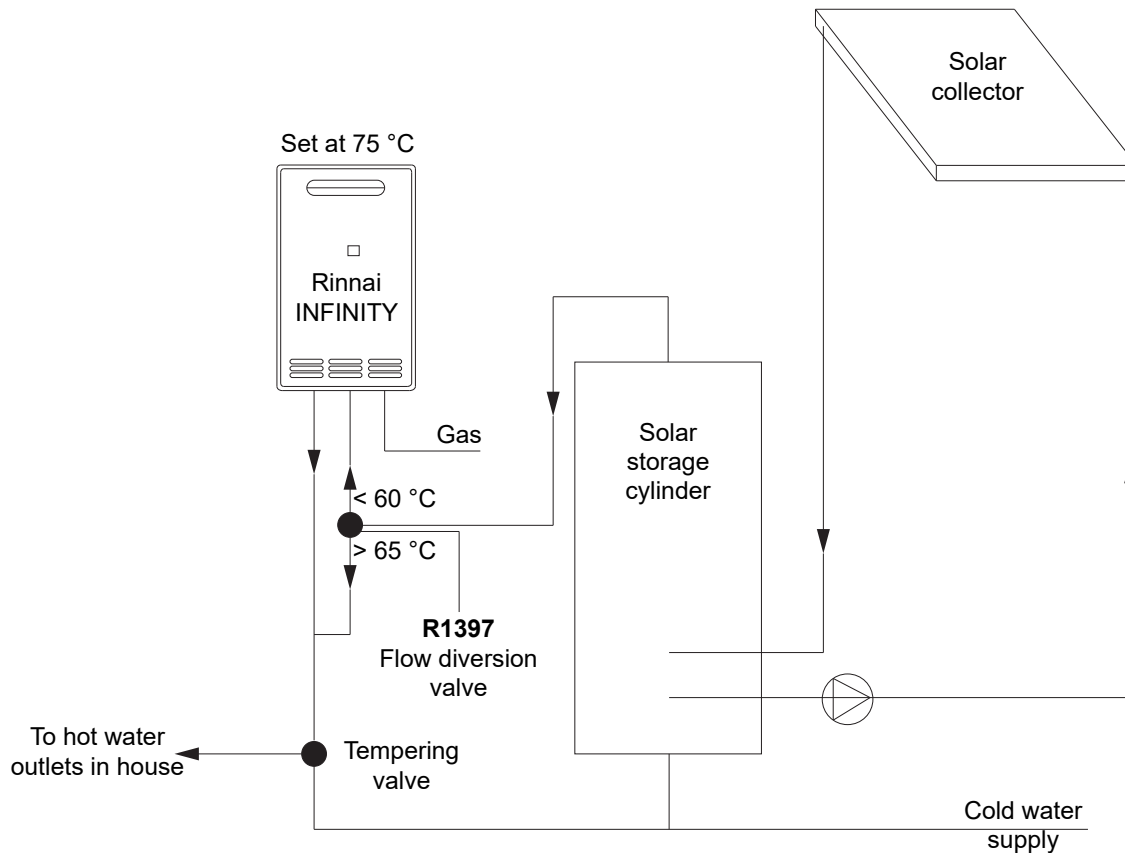

# Appendix 4

## Rinnai INFINITY Limited Warranty

### Rinnai warranty summary table

This warranty is applicable for all Rinnai INFINITY continuous flow water heaters manufactured from 2019 onwards. All terms of the warranty, subject to the conditions below, are effective from the date of first installation. The attending service person reserves the right to verify this by requesting a copy of the gas certificate of compliance prior to commencement of any warranty work. Proof of purchase and installation date will be required at the time of any warranty claim. This warranty is only valid within the country of purchase.

Rinnai INFINITY	Application	HEAT EXCHANGER		ALL OTHER PARTS	
		Parts	Labour	Parts	Labour
EF26 and A-Series models	Residential WITHOUT controllers	10 years pro rata <sup>1</sup>	3 years	3 years	3 years
	Residential WITH controllers	12 years pro rata <sup>1</sup>	3 years	5 years	3 years
	Commercial	1500 hours or 1 year <sup>2</sup>	1500 hours or 1 year <sup>2</sup>	1500 hours or 1 year <sup>2</sup>	1500 hours or 1 year <sup>2</sup>
HD and N-Series models	Residential	12 years pro rata <sup>1</sup>	3 years	5 years	3 years
	Commercial	5000 hours or 3 years pro rata <sup>2</sup>	1500 hours or 1 year <sup>2</sup>	1500 hours or 1 year <sup>2</sup>	1500 hours or 1 year <sup>2</sup>

<sup>1</sup> Under a pro rata warranty, if the heat exchanger fails before the end of the warranty, Rinnai will replace the heat exchanger at a cost that depends on the age of the heat exchanger at the time of the fault. For further details refer to the pro rata table on p.49.

<sup>2</sup> Whichever comes first

### Residential application

A residential application is defined as an installation where a continuous flow unit is set to 55 °C<sup>3</sup> or lower, delivering hot water to a single residential dwelling (not used for commercial purposes<sup>4</sup>).

All other installations are defined as commercial applications.

For constant use applications, such as circulating ring mains, the water heater, must be sized and installed according to written guidelines from Rinnai.

### General warranty terms

Rinnai reserves the right to make modifications and change specifications and its parts without notice.

For the purposes of the Consumer Guarantees Act 1993, Rinnai only guarantees the availability of repair facilities and spare parts for the express warranty period recorded in the table above.

This warranty does not limit any consumer rights or guarantees that may apply under the Consumer Guarantees Act 1993. If the product is being acquired for the purposes of a business, the provisions of the Consumer Guarantees Act 1993 do not apply and no other warranties (either express or implied by law) apart from those stated in the warranty will apply.

<sup>3</sup> A solar installation using a Rinnai INFINITY continuous flow unit (excluding EF26 and A-Series external models) in a single residential dwelling is considered a residential application.

<sup>4</sup> Examples of a commercial application in a residential dwelling; hair salon, catering kitchen, communal care facility etc. An accommodation business such as a motel, where a continuous flow unit serves the equivalent of a single family dwelling, is deemed to be a residential application.

## Warranty terms and conditions

1. All terms of the warranty are effective from the date of first installation. The attending service person reserves the right to verify this by requesting a copy of the gas certificate of compliance prior to commencement of any warranty work. The installer must issue a certificate of compliance by law in New Zealand. Warranty claims may be invalid if not accompanied by details of the installing or supervising gasfitter's registration number and the gas certification number.
2. All Rinnai appliances must be installed, commissioned, serviced, repaired and removed in accordance with the manufacturer's installation instructions, local regulations, and building codes by persons authorised by local regulations to do so.
3. All appliances must be operated and maintained in accordance with the manufacturer's operating instructions.
4. Servicing of the product is to be carried out by a Rinnai authorised service centre.
5. The warranty applies only to the components supplied by Rinnai. It does not apply to components supplied by others, such as electrical switches, electrical cables, fuses, isolating valves, pipework, and where applicable flue systems, but it is not limited to these.
6. Where the appliance has not been sited in accordance with the installation instructions or installed such that normal access is difficult, a service charge will apply. If at the discretion of the attending service person the installation is deemed illegal or access is dangerous, service will be refused. Any work required to gain reasonable access to the appliance will be chargeable by the attending service person (for example, removal of cupboards, doors, walls, or the use of special equipment to move components, but not limited to these).
7. Where the failed component is replaced under warranty, the balance of the original warranty will remain effective.
8. Rinnai reserves the right to transfer functional components from defective appliances if they are suitable.
9. Rinnai reserves the right to have installed product returned to the factory for inspection.
10. Where the water heater is installed outside the metropolitan area or further than 40 km from a Rinnai authorised service centre, travel costs shall be the owner's responsibility.

## Warranty exclusions

The following exclusions may cause the warranty to become void and will result in a service charge and costs of parts (if required).

1. Accidental damage and acts of God.
2. Failure due to abuse or misuse, improper maintenance or improper storage.
3. Failure due to incorrect or unauthorised installations.
4. Failure or damage caused by alterations, service or repair work carried out by persons other than Rinnai service persons or service centres.
5. Where the water heater has failed directly or indirectly as a result of poor water quality outside the limits specified.
6. Where it is found that there is no fault with the appliance and the issue is related to the installation or is due to failure of electric or gas supplied.
7. Subject to any statutory provisions to the contrary, Rinnai does not accept
  - a. liability for consequential damage or incidental expenses resulting from any breach of the warranty.
  - b. claims for damage to building or any other consequential loss either directly or indirectly due to leaks from the appliance or any other faults.

## Pro rata heat exchanger warranty table

Under a pro rata warranty, if the **heat exchanger** fails before the end of the warranty, Rinnai will replace the heat exchanger at a cost that depends on the installation application and the age of the heat exchanger at the time of the fault.

Year	EF26 and A-SERIES		HD and N-SERIES	
	Residential WITHOUT controllers	Residential WITH controllers	Residential	Commercial
1	100%	100%	100%	33.3%
2	100%	100%	100%	33.3%
3	100%	100%	100%	33.3%
4	70%	90%	90%	-
5	60%	80%	80%	-
6	50%	70%	70%	-
7	40%	60%	60%	-
8	30%	50%	50%	-
9	20%	40%	40%	-
10	10%	30%	30%	-
11	-	20%	20%	-
12	-	10%	10%	-

The percentages above relate to the heat exchanger component only. It does not include labour.



# Water quality



Water quality outside the limits (as set down below) will void this warranty.

## Water quality and impurity limits

TDS (Total Dissolved Solids)	Total hardness CaCO <sub>3</sub>	Alkalinity (as CaCO <sub>3</sub> )	Dissolved (free) CO <sub>2</sub>	pH	Chlorides	Magnesium	Sodium	Iron	Langelier Index
Up to 600 mg/L or ppm	Up to 200 mg/L or ppm	Up to 200 mg/L or ppm	Up to 25 mg/L or ppm	6.5-8.5	Up to 300 mg/L or ppm	Up to 10 mg/L or ppm	Up to 150 mg/L or ppm	Up to 1 mg/L or ppm	Between -1.0-0.8

Most metropolitan water supplies fall within these limits. If sludge or foreign matter is present in the water supply, a suitable filter should be incorporated in the water supply.

Some examples of water quality issues where water may need to be treated:

- Hard water (areas including Whanganui)
- Aggressive water (areas including Christchurch)
- Both hard and aggressive water (some bore water)

## Appendix 5

# LPG gas bottle consumption and cylinder clearances

### LPG gas bottle consumption

We often get asked about how long a gas bottle will last when running a gas appliance. Using the calculation below you can work this out yourself.

### LPG gas bottle energy calculation

1 kg of LPG gas contains 50.4 MJ of energy. This means that a 45 kg LPG has bottle has  $45 \text{ kg} \times 50.4 \text{ MJ} = 2268 \text{ MJ}$ . This calculation works for different gas bottle sizes, here are the most common:

- 9 kg = 453.6 MJ
- 45 kg = 2268 MJ
- twin pack = 4536 MJ (two 45 kg bottles)

### Calculating how long an LPG bottle will last

To work out how many hours an LPG bottle will last you need to divide the energy (MJ) of the gas bottle by the total MJ input of the appliance.

For example:

A household has an A26 installed which runs approximately 20 minutes a day, three five minute showers and intermittent use of vanity and kitchen taps (approx. five minutes).

- $2268 \div 199 \text{ MJ/h}$  (maximum input of unit)  
= 11.40 hours (running at full capacity)
- 11.40 hours x 60 minutes = 684 minutes
- 684 minutes  $\div$  20 minutes (use per day)  
= 34.2 days (approx. one 45 kg per month)

The above example is based on the unit operating at a maximum flow rate and MJ/h input (26 L/min and 199 MJ/h). In the real-world this won't be the case as the flow rate and gas consumption when using vanity and kitchen taps is much lower (2.4 L/min and 13 MJ/h), so in reality the gas bottle will last a little longer.

**Please note:** This doesn't factor other gas appliances in the house.

For more information you can search the internet (how long will a 45 kg gas bottle last) as there are additional resources and blogs available.

### Overview of LPG cylinder clearances

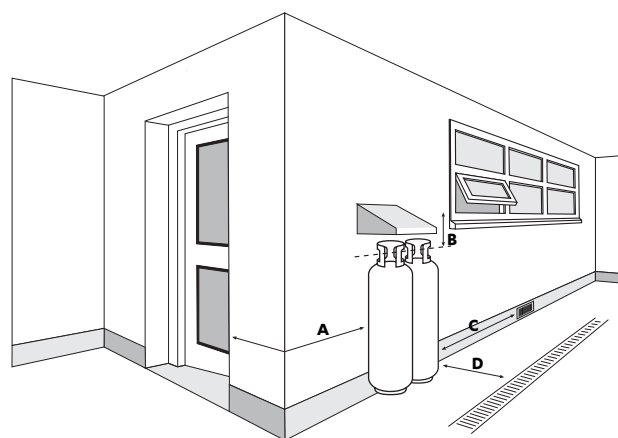

A	Min. clearance to a door	1 m
B	Min. clearance to an openable window	150 mm
C	Min. clearance to an air vent or opening	1 m
D	Min. clearance to a drain	1 m

The above diagram is a modified version of a drawing originally produced by ongas ([www.ongas.co.nz](http://www.ongas.co.nz)). It is intended to provide an overview of the general clearances required for LPG cylinders.

For detailed information relating to LPG cylinder placement it is advisable to consult a licensed gasfitter, your nearest LPG cylinder supplier, or consult AS/NZS 5601.1 Gas Installations.

## Appendix 6

# The future of gas in New Zealand

Extract from <https://www.gasenergy.org.nz/future-sure> website which also contains a handy downloadable Future Sure information sheet.

**The flame isn't going out. Kiwi gas users can be confident that the gas they turn on isn't being turned off and will continue to flow well into the future.**

If you're connected to gas now or thinking about connecting, you can be sure that natural gas and LPG will keep flowing as we make the shift to future low or zero carbon gases.

### **Gas energy is here to stay**

The Climate Change Commission has not proposed a ban on new gas connections from 2025 but instead recommend the government sets a date, once a national energy strategy is developed and there is more clarity around the contribution future gases can make in decarbonising New Zealand's energy supply.



You can also be confident that you can use any natural gas or LPG appliances in your home for their expected lifetime. Current LPG appliances are fully compatible with BioLPG, and modern gas appliances are already able to run on a blend of natural gas and renewable hydrogen gas (up to 20%) or biogas. New compatible appliances will become widely available as we scale up towards a more renewable gas energy future.

Gas energy is here to stay, but it will be changing. What isn't changing is the value and benefits you get living in a home energised by gas.

### **If you like today's gas, you'll love tomorrow's**

New renewable, low and zero carbon gases are the future. With hydrogen gas and biogas already being developed and trialled here in New Zealand and globally, Kiwis will continue to enjoy the benefits of gas in their lives as we move to tomorrow's gas energy.

Green hydrogen gas, made from renewable energy and water, can be used on its own or blended with natural gas to reduce carbon emissions. Renewable biogas is produced through the breakdown of organic waste (e.g. compost). BioLPG, produced from biomass (e.g. forest, crop or farm waste) is chemically identical to LPG and a direct energy replacement for your BBQ or LPG appliances.

It's likely that the blending of traditional gas with future gases like green hydrogen gas and biogas will happen in the next 3-5 years. Just like today's gas, these new gases will be subject to rigorous safety protocols and standards before they are available to homes and businesses.

### **Gas will help us get to 100% renewable energy**

Gas energy is an important part of New Zealand's energy future. The Climate Change Commission's advice to the government on achieving our climate and carbon emissions targets acknowledges the role that low and zero carbon gases can play in decarbonising New Zealand's energy system and reducing the impact of climate change on our environment. New gas energy will help us achieve our 100% renewable energy aspirations and a net-zero carbon future by 2050.



## Notes



## Notes

**Rinnai.co.nz**

Tel: 0800 746 624

<http://www.youtube.com/rinnainz>

<http://facebook.com/rinnainz>