

Indoor wiring diagram:

- 2.6 kW
- 3.5 kW
- 5.0 kW
- 6.0 kW

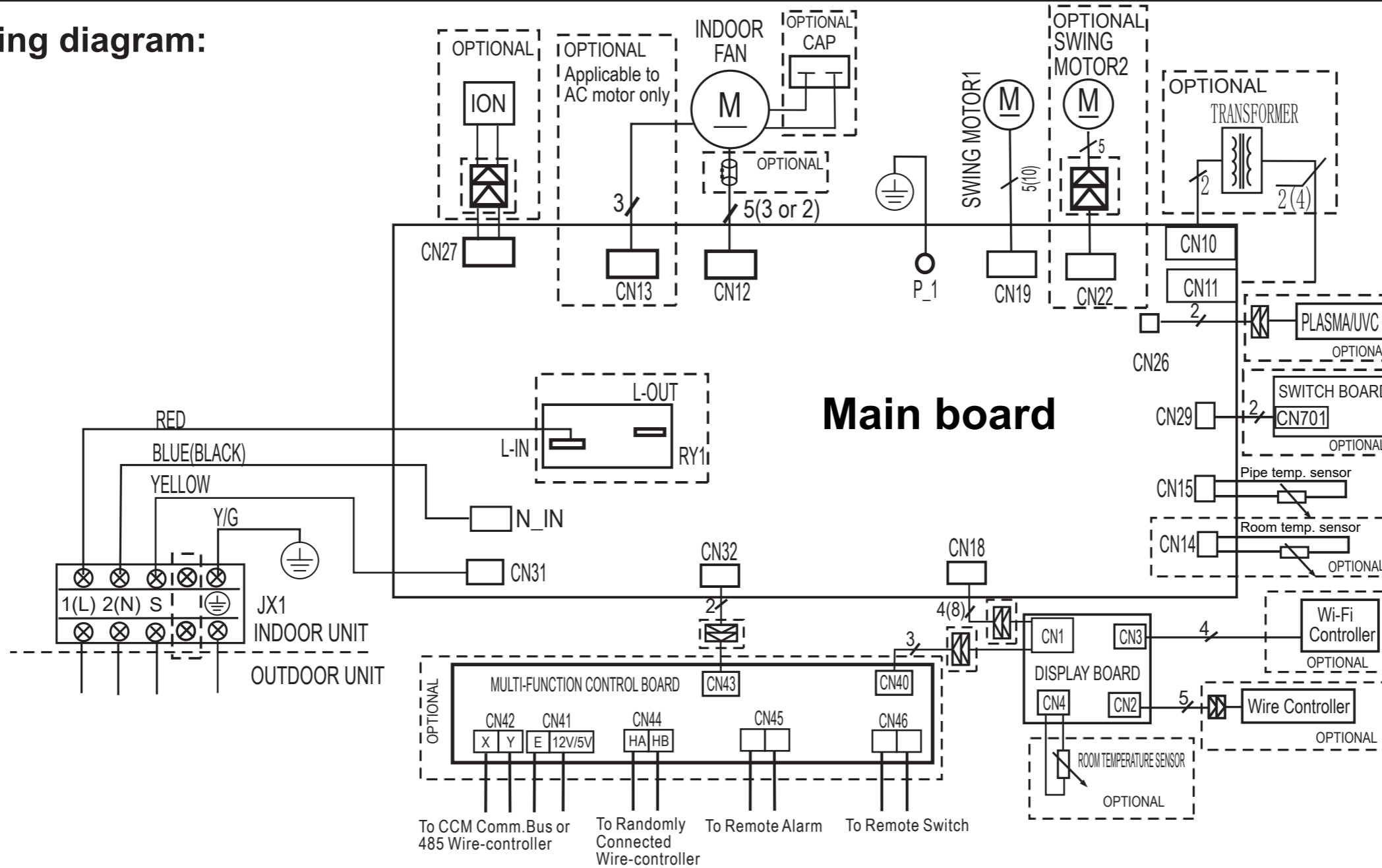

----- This symbol indicates the element is optional, the actual shape shall prevail.

FOR SETTING NETADDRESS (CCM Comm.Bus)				
ENC3+F1 (MULTI-FUNCTION CONTROL BOARD)				
CODE	0~F	0~F	0~F	0~F
NETADDRESS	0~15	16~31	32~47	48~63
FACTORY SETTING	<input checked="" type="checkbox"/>	<input type="checkbox"/>	<input type="checkbox"/>	<input type="checkbox"/>

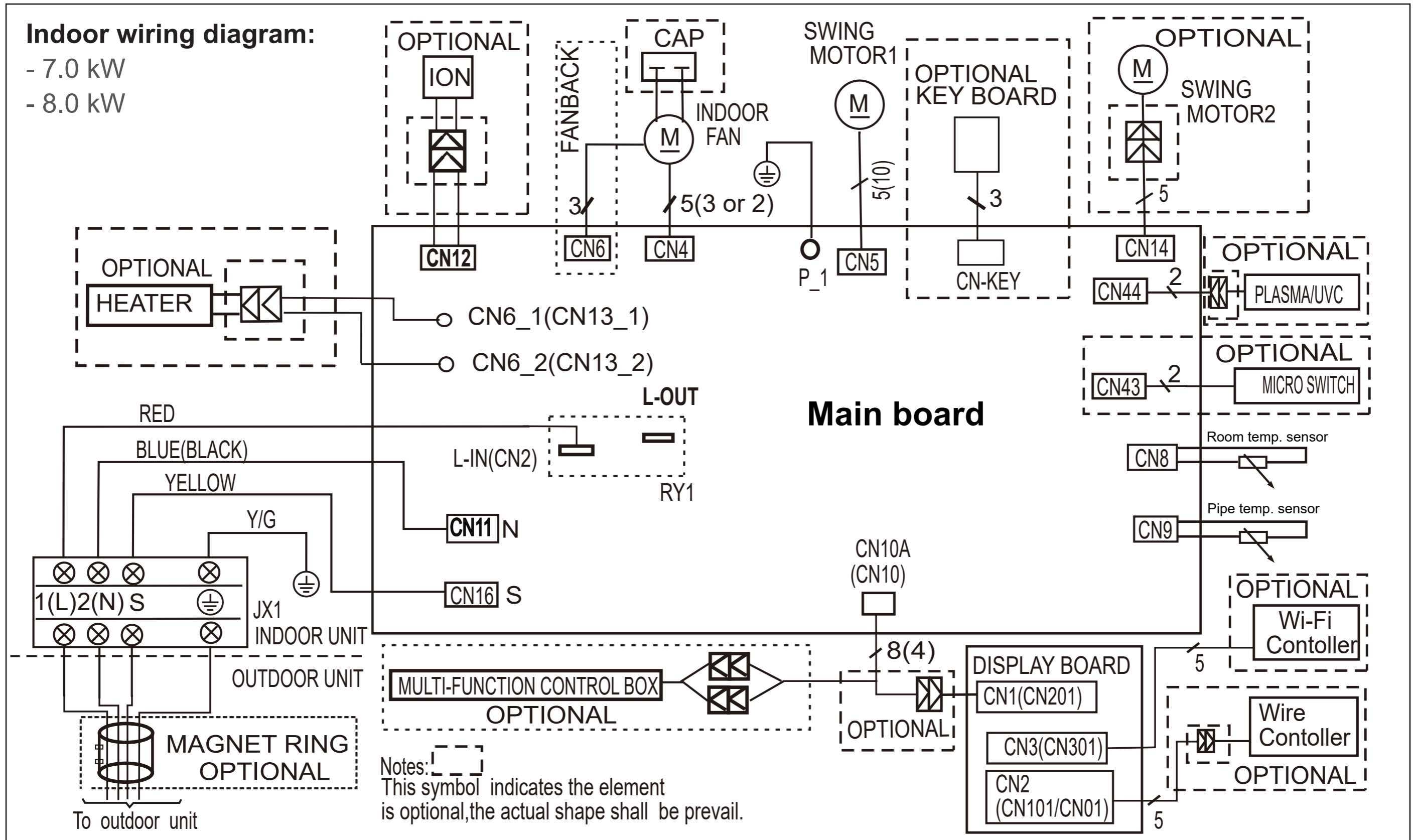

Outdoor wiring diagram:

- 2.6 kW
- 3.5 kW

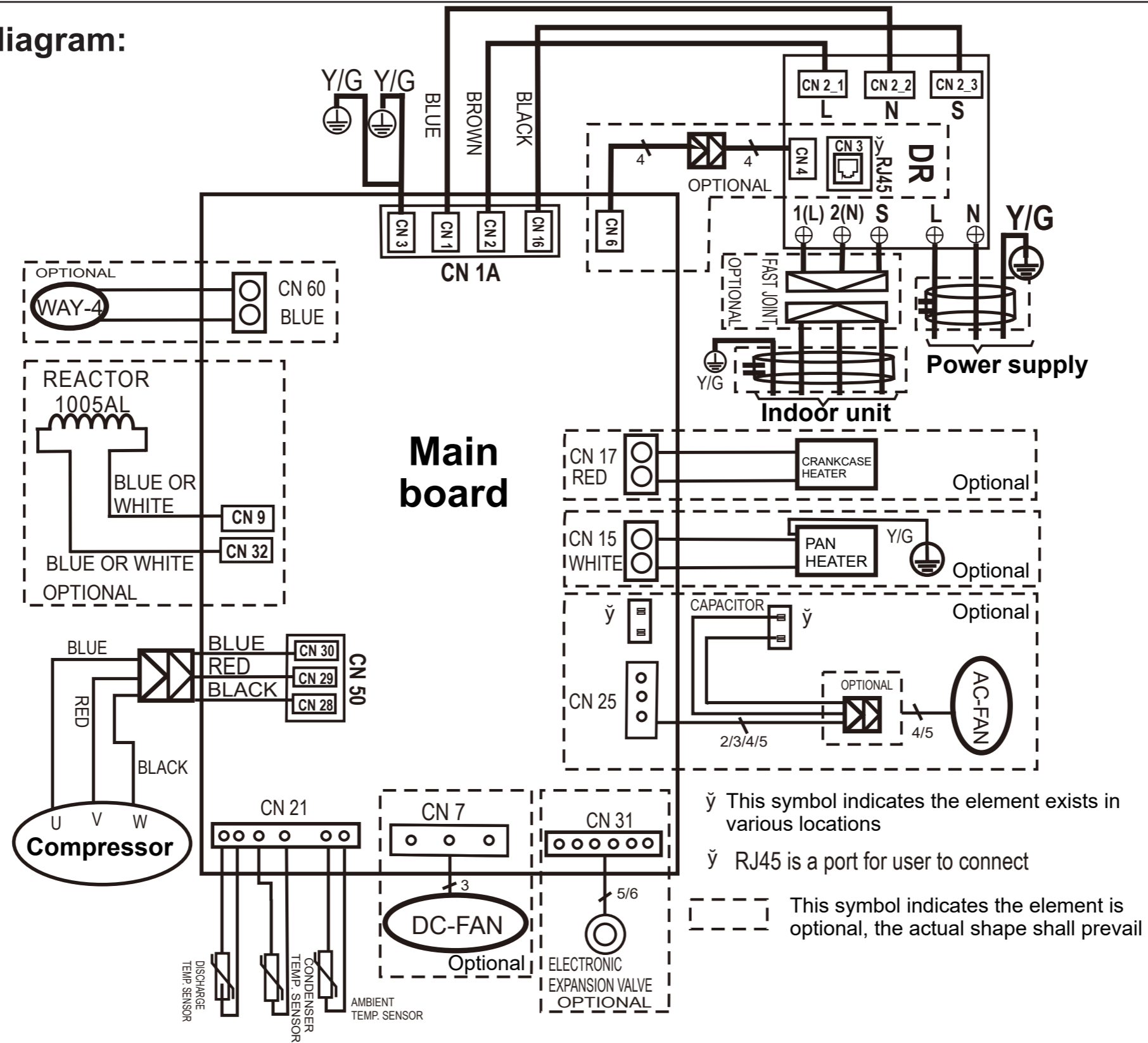

Outdoor wiring diagram:

- 5.0 kW
- 6.0 kW
- 7.0 kW
- 8.0 kW

